

# Al-Anon Alateen

## Service Manual 2014-2017



**Al-Anon and Alateen Groups at Work**

**Digest of Al-Anon/Alateen Policies**

**World Service Handbook**

**Al-Anon World Service Conference Charter**

**Al-Anon's Twelve Concepts of Service**



# 2014-2017 Al-Anon/Alateen Service Manual

The World Service Office (WSO) supplies one copy of this *Manual* without charge to each registered group, to serve as a source of reference. It should be passed along to each succeeding Secretary, who will act as its temporary custodian.

Every Al-Anon and Alateen member is encouraged to own and study this *Manual*. It gives a clear and concise picture of the Al-Anon fellowship, its purpose and functions and how it helps us to resolve group problems and maintain unity. Additional copies may be ordered from the WSO or from your Literature Distribution Center.

Those who wish to translate this *Manual* for use by Al-Anon and Alateen groups abroad may obtain permission by writing to the address on the back of the title page.

Al-Anon Family Group Headquarters, Inc.  
Al-Anon/Alateen World Service Office  
Virginia Beach, VA

All photos were donated by Al-Anon/Alateen members.

The Al-Anon Family Groups are a fellowship of relatives and friends of alcoholics who share their experience, strength, and hope in order to solve their common problems. We believe alcoholism is a family illness and that changed attitudes can aid recovery.

Al-Anon is not allied with any sect, denomination, political entity, organization, or institution; does not engage in any controversy; neither endorses nor opposes any cause. There are no dues for membership. Al-Anon is self-supporting through its own voluntary contributions.

Al-Anon has but one purpose: to help families of alcoholics. We do this by practicing the Twelve Steps, by welcoming and giving comfort to families of alcoholics, and by giving understanding and encouragement to the alcoholic.

Suggested Preamble to the Twelve Steps

For information and catalog of literature write:  
Al-Anon Family Group Headquarters, Inc.  
World Service Office for Al-Anon and Alateen  
1600 Corporate Landing Parkway  
Virginia Beach, VA 23454-5617  
Phone 757-563-1600 Fax 757-563-1655  
www.al-anon.alateen.org email: wso@al-anon.org  
Members' site: www.al-anon.alateen.org/members

AL-ANON AND ALATEEN GROUPS AT WORK  
Al-Anon Family Group Headquarters, Inc., 1964

DIGEST OF AL-ANON AND ALATEEN POLICIES  
Al-Anon Family Group Headquarters, Inc., 1975

WORLD SERVICE HANDBOOK  
Al-Anon Family Group Headquarters, Inc., 1973

AL-ANON'S TWELVE CONCEPTS OF SERVICE  
Al-Anon Family Group Headquarters, Inc., 1970

Al-Anon/Alateen is supported by members' voluntary contributions and from the sale of our Conference Approved Literature.

This *Manual* is available in Spanish and French.

All rights reserved. No part of this publication may be reproduced, stored in or introduced into a retrieval system, or transmitted, in any form, or by any means (electronic, mechanical, photocopying, recording, or otherwise), without the prior written permission of the publisher.

© Al-Anon Family Group Headquarters, Inc., 1992  
Revised 2013



Portions Approved by  
World Service Conference  
Al-Anon Family Groups

# Preface

Questions pertaining to the Twelve Traditions and the Twelve Concepts of Service continually arise within our fellowship. Over the years, four booklets were introduced to assist members in resolving specific situations. In 1992, the four booklets were combined into one and retitled *Al-Anon/Alateen Service Manual* (P-24/27). This *Manual* reflects the collective experience of our membership in its ongoing effort to interpret the Traditions and Concepts of Service in a spirit of unity and harmony.

Members seeking answers to specific questions of special situations may well find guidance within these pages. The Contents pages (now on a tabbed divider for each section) and an Index list the many topics addressed.

To reflect new information and changing points of view, an on-line version of the *Manual* is updated between printings as changes are made. It can be found on the Members' Web site, [www.al-anon.alateen.org/members](http://www.al-anon.alateen.org/members). Al-Anon/Alateen members may initiate revisions to the *Manual* at any time by making suggestions to their District Representative (DR), Area Delegate, or the World Service Office (WSO).

For this 2014-2017 edition, the "Al-Anon and Alateen Groups at Work" section is also being printed as a separate booklet (P-24), in the hopes of making this important group information available to more members worldwide.

# Al-Anon Declaration

## *Let It Begin with Me*

When anyone, anywhere, reaches out for help,  
let the hand of Al-Anon and Alateen  
always be there, and—*Let It Begin with Me.*

# Contents

<b>Preface</b> .....	3
<b>Al-Anon and Alateen Groups at Work</b> .....	<b>7</b>
Introduction.....	7
Suggested Meeting Format Outline .....	8
Suggested Meeting Format Readings.....	10
History: Al-Anon and Alateen .....	28
How to Start a Group.....	30
Basics for Group Meetings .....	40
Group Service Positions .....	46
Sponsorship.....	48
Supporting Group Growth .....	49
Group Business .....	51
Resources for Members and Groups .....	60
Structure of the Al-Anon/Alateen Fellowship .....	62
Basic Terms Used in Al-Anon Service .....	70
<b>Digest of Al-Anon and Alateen Policies</b> .....	<b>79</b>
Introduction.....	79
Channel for Arriving at Policies .....	79
World Service Conference (WSC) .....	80
World Service Office .....	80
Membership and Group Meetings/Conventions .....	81
Alateen Policy.....	87
Anonymity .....	91
Financial Matters .....	95
Local Services .....	100
Conference Approved Literature and Service Tools/Materials.....	102
Public Outreach .....	109
Incorporation/Taxes .....	117
Al-Anon As It Relates to Others .....	120
<b>World Service Handbook</b> .....	<b>131</b>
Introduction.....	131
Terms Used in Al-Anon .....	131
World Service Office .....	135
World Service Conference .....	139

Conference Structure .....	141
Conference Procedures.....	146
Election Assembly Procedure .....	149
General Information for Assemblies .....	153
Duties of Assembly Members .....	155
Area World Service Committee.....	162
Interim Assemblies .....	163
District Meetings .....	164
Chart: World Service Conference Structure .....	166

**AI-Anon World Service Conference Charter..... 171**

**AI-Anon's Twelve Concepts of Service ..... 179**

History of the Concepts.....	179
Introduction .....	180
Concept One.....	181
Concept Two.....	183
Concept Three .....	185
Concept Four .....	188
Concept Five .....	190
Concept Six .....	193
Concept Seven .....	194
Concept Eight .....	196
Concept Nine .....	198
Concept Ten.....	203
Concept Eleven .....	207
Concept Twelve.....	214
Amendments .....	229

**APPENDIX ..... 287**

**INDEX..... 294**

# Al-Anon and Alateen Groups at Work

*“Al-Anon and Alateen Groups at Work” provides a framework within which each group can develop and grow. It offers basic information to all group members concerning the group structure and how it relates to other groups and Al-Anon as a whole.*

## Table of Contents

Introduction	7
Suggested Meeting Format Outline	8
Suggested Meeting Format Readings	10
The Serenity Prayer	10
Suggested Al-Anon/Alateen Welcome	10
Suggested Al-Anon Preamble to the Twelve Steps	12
Suggested Alateen Preamble to the Twelve Steps	12
Our Three Legacies	13
Twelve Steps	13
Twelve Traditions – Al-Anon	15
Twelve Traditions – Alateen	17
Twelve Concepts of Service	19
General Warranties of the Conference	20
Suggested Al-Anon/Alateen Closing	22
Al-Anon Declaration	22
Optional Readings	23
Reading on Anonymity	23
Four Primary Ideas	23
Three Obstacles to Success in Al-Anon	24
Understanding Alcoholism	25
Understanding Ourselves	26
History: Al-Anon and Alateen	28
How to Start a Group	30
Starting an Al-Anon Family Group	30
Reasons for Registration	30
WSO Registration Process	30
Starting an Alateen Group	31
How to Start an Alateen Group	32
The Alateen Meeting	33
Things to Consider when Starting an Al-Anon or Alateen Group	34
CMA (Current Mailing Address)	34
Phone Contacts	34
Where to Hold Group Meetings	35

*Note: Vertical lines in outer margins indicate where changes were made for this edition.*



Naming the Group	35
Meeting Type: Open/Closed Meetings	36
Beginners' Meetings	37
Multiple Meetings	37
Getting the Meeting Started	38
Starting an Electronic Al-Anon Meeting	38
Initial Group Service Positions	39
<b>Basics for Group Meetings</b>	<b>40</b>
Membership	40
Sharing in Al-Anon/Alateen Meetings	40
Welcoming New Members	41
Anonymity	41
Meeting Ideas	43
<b>Group Service Positions</b>	<b>46</b>
Suggested Duties of Group Officers/Leaders	46
<b>Sponsorship</b>	<b>48</b>
Al-Anon Personal Sponsors	48
Service Sponsors	49
Alateen Group Sponsors	49
Alateen Personal Sponsors	49
<b>Supporting Group Growth</b>	<b>49</b>
Public Outreach in the Community	50
<b>Group Business</b>	<b>51</b>
Group Records	51
Group Business Meetings and Group Conscience	51
Group Inventory	53
Group Problems and Solutions	54
Group Reports and Announcements	55
Group Finances/Budget	56
<b>Resources for Members and Groups</b>	<b>60</b>
Al-Anon Web Sites	60
Guidelines Relevant to Groups	60
Newsletters/Timely Publications	61
Literature and Service Materials	61
<b>Structure of the Al-Anon/Alateen Fellowship</b>	<b>62</b>
Group Structure	62
Districts	63
Al-Anon Information Service (AIS/Intergroup)	63
Areas	65
World Service Conference (WSC)	66
World Service Office (WSO)	67
<b>Basic Terms Used in Al-Anon Service</b>	<b>70</b>

# Introduction

The message of the Al-Anon Family Groups, Al-Anon and Alateen, is one of hope. It is the story of men, women, and children who once felt helpless, lost, and lonely because of another's alcoholism. Although Al-Anon grew from a need expressed by family members of Alcoholics Anonymous, Al-Anon and Alateen offer help and hope to friends and families of alcoholics whether the alcoholic is still drinking or not. While many of our members no longer maintain daily contact with an alcoholic, they seek the mutual support Al-Anon and Alateen groups offer.

Al-Anon is a unique fellowship that unites members of different backgrounds, races, and walks of life in an inspiring endeavor: helping themselves and others to lead purposeful, useful lives by overcoming the frustration and helplessness caused by close association with an alcoholic.

Alateen (Al-Anon for younger members) is a vital part of Al-Anon Family Groups. Young people seeking help with problems that arise when alcoholism afflicts a parent, another close relative, or a friend meet to exchange experiences and to gain an understanding of themselves and the alcoholic. This helps their own personal development and can help stabilize troubled thinking resulting from close association with an alcoholic.

“Al-Anon and Alateen Groups at Work” explains how to start a group, help it grow, and discover how other members have solved problems common to groups (note that in countries outside of the World Service Conference structure, terms mentioned may vary according to need). The harmony and success of each group depends on shared responsibility, a warm spirit of fellowship, and individual self-improvement.

Today these men, women, and children have courage and confidence. They have found understanding and learned what to do to help themselves--and this can indirectly help their alcoholic relatives, loved ones, and friends, whether sober or not. Al-Anon will always be what we its members make it. Al-Anon believes that our benefits are measured by our willingness to share them with others. For we know we can never give as much as we receive.

# Suggested Meeting Format Outline

*This format is included for your convenience. While not every group chooses to plan its meeting in this way, many find a general outline helpful. Groups may use blank spaces to insert information specific to the group.*

## Meeting Opening

Most groups open with a moment of silence followed by the Serenity Prayer.

## Suggested AI-Anon/Alateen Welcome (page 10)

After reading the Suggested AI-Anon/Alateen Welcome, many groups will have the Chairperson announce any special format and any group guidelines for the running of the meeting, ask members of other anonymous fellowships to remain anonymous and keep the focus on the AI-Anon program, and clarify whether the meeting is open\* or closed.\*\*

\*This is an open meeting; we welcome visitors seeking information about AI-Anon as well as newcomers and members of AI-Anon.

\*\*This is a closed meeting for AI-Anon members and prospective members only. Anyone who has been affected by someone else's drinking is welcome.

(See also "Meeting Type: Open/Closed.")

## Reading of AI-Anon/Alateen's Three Legacies (pages 12-20)

Many groups choose to have a member read one, or all, of the following:

- Suggested AI-Anon Preamble to the Twelve Steps (page 12)
- Twelve Steps (pages 13-14)
- Twelve Traditions (pages 15-18)
- Twelve Concepts of Service/General Warranties (pages 19-20)

## Other readings selected by the group conscience

See pages 23-27 for optional readings including:

- AI-Anon/Alateen Anonymity Statement

- “Three Obstacles to Success in Al-Anon”
- “The Twelve Steps suggest acceptance of four primary ideas”
- *Understanding Ourselves and Alcoholism* (P-48)

## Introductions

The Chairperson invites everyone to introduce themselves. Members may choose to use their first name only or their entire name, according to their personal preference.

The Chairperson may ask newcomers to identify themselves and welcomes them. (See page 41 for more on welcoming new members.)

## Al-Anon/Alateen-Related Announcements, Reports

This is a time for announcement of local Al-Anon events, service meetings, and other group business, including day and time of business meetings, treasurer’s report, and mail from the district, Area, or World Service Office.

## The Program

See pages 43-45 for meeting ideas.

## Passing the Basket

The Chairperson lets the group know that Al-Anon has no dues or fees, but according to the Seventh Tradition, Al-Anon/Alateen groups ought to be self-supporting through members’ voluntary contributions. The basket is passed to cover group expenses, including rent, purchase of literature, and support of trusted servants and Al-Anon’s service arms. Members and newcomers are encouraged to contribute in gratitude for what Al-Anon/Alateen has given them. The amount is not important; what is important is that they give whatever they can.

## Suggested Al-Anon/Alateen Closing (page 22)

After reading the “Suggested Closing,” groups close in a manner agreeable to the group conscience.

# Suggested Meeting Format Readings

*This format is printed for your convenience. While not every group chooses to plan its meeting in this way, many find a general outline helpful.*

See also the pamphlet *This Is Al-Anon* (P-32).

## The Serenity Prayer

Chairperson: Will you join me in a moment of silence, followed by the Serenity Prayer?

God grant me the serenity  
 To accept the things I cannot change,  
 Courage to change the things I can,  
 And wisdom to know the difference.

## Suggested Al-Anon/Alateen Welcome

*(choose "Al-Anon" or "Alateen" as applicable)*

We welcome you to the \_\_\_\_\_ Al-Anon/Alateen Family Group and hope you will find in this fellowship the help and friendship we have been privileged to enjoy.

We who live, or have lived, with the problem of alcoholism understand as perhaps few others can. We, too, were lonely and frustrated, but in Al-Anon/Alateen we discover that no situation is really hopeless and that it is possible for us to find contentment, and even happiness, whether the alcoholic is still drinking or not.

We urge you to try our program. It has helped many of us find solutions that lead to serenity. So much depends on our own attitudes, and as we learn to place our problem in its

true perspective, we find it loses its power to dominate our thoughts and our lives.

The family situation is bound to improve as we apply the Al-Anon/Alateen ideas. Without such spiritual help, living with an alcoholic is too much for most of us. Our thinking becomes distorted by trying to force solutions, and we become irritable and unreasonable without knowing it.

The Al-Anon/Alateen program is based on the Twelve Steps (adapted from Alcoholics Anonymous), which we try, little by little, one day at a time, to apply to our lives, along with our slogans and the Serenity Prayer. The loving interchange of help among members and daily reading of Al-Anon/Alateen literature thus make us ready to receive the priceless gift of serenity.

Anonymity is an important principle of the Al-Anon/Alateen program. Everything that is said here, in the group meeting and member-to-member, must be held in confidence. Only in this way can we feel free to say what is in our minds and hearts, for this is how we help one another in Al-Anon/Alateen.

*At this point in the meeting, many groups have the Chairperson say if the group meeting has a special format (Step-study, speakers, or discussion group), has a specific routine for calling on members, asks members of other anonymous fellowships to remain anonymous and focus on the Al-Anon program, and clarifies if the meeting is open\* or closed.\*\* Members are also told how they can obtain Al-Anon and Alateen Conference Approved Literature.*

\*This is an open meeting; we welcome visitors seeking information about Al-Anon as well as newcomers and members of Al-Anon.

\*\*This is a closed meeting for Al-Anon members and prospective members only. Anyone who has been affected by someone else's drinking is welcome.

*See also "Meeting Type: Open/Closed."*

## **Suggested Al-Anon Preamble to the Twelve Steps**

The Al-Anon Family Groups are a fellowship of relatives and friends of alcoholics who share their experience, strength, and hope in order to solve their common problems. We believe alcoholism is a family illness and that changed attitudes can aid recovery. Al-Anon is not allied with any sect, denomination, political entity, organization, or institution; does not engage in any controversy; neither endorses nor opposes any cause. There are no dues for membership. Al-Anon is self-supporting through its own voluntary contributions.

Al-Anon has but one purpose: to help families of alcoholics. We do this by practicing the Twelve Steps, by welcoming and giving comfort to families of alcoholics, and by giving understanding and encouragement to the alcoholic.

## **Suggested Alateen Preamble to the Twelve Steps**

Alateen, part of the Al-Anon Family Groups, is a fellowship of young people whose lives have been affected by alcoholism in a family member or close friend. We help each other by sharing our experience, strength, and hope.

We believe alcoholism is a family disease because it affects all the members emotionally and sometimes physically. Although we cannot change or control our parents, we can detach from their problems while continuing to love them.

We do not discuss religion or become involved with any outside organizations. Our sole topic is the solution of our problems. We are always careful to protect each other's anonymity as well as that of all Al-Anon and A.A. members.

By applying the Twelve Steps to ourselves, we begin to grow mentally, emotionally, and spiritually. We will always be grateful to Alateen for giving us a wonderful, healthy program to live by and enjoy.

*Many groups choose to have a member read one, or all, of the Twelve Steps, Twelve Traditions, and/or Twelve Concepts of Service.*

## **Our Three Legacies**

**RECOVERY  
THROUGH  
THE  
STEPS**

**UNITY  
THROUGH  
THE  
TRADITIONS**

**SERVICE  
THROUGH  
THE  
CONCEPTS**

The threefold guides of Al-Anon point the way to a normal, useful life for the individual. They also are a framework within which the groups can carry on their affairs in harmony.

## **Twelve Steps**

Because of their proven power and worth, A.A.'s Twelve Steps have been adopted almost word for word by Al-Anon. They represent a way of life appealing to all people of good-will, of any religious faith or of none. Note the power of the very words!

1. We admitted we were powerless over alcohol—that our lives had become unmanageable.
2. Came to believe that a Power greater than ourselves could restore us to sanity.
3. Made a decision to turn our will and our lives over to the care of God *as we understood Him*.
4. Made a searching and fearless moral inventory of ourselves.
5. Admitted to God, to ourselves, and to another human being the exact nature of our wrongs.
6. Were entirely ready to have God remove all these defects of character.



7. Humbly asked Him to remove our shortcomings.
8. Made a list of all persons we had harmed, and became willing to make amends to them all.
9. Made direct amends to such people wherever possible, except when to do so would injure them or others.
10. Continued to take personal inventory and when we were wrong promptly admitted it.
11. Sought through prayer and meditation to improve our conscious contact with God *as we understood Him*, praying only for knowledge of His will for us and the power to carry that out.
12. Having had a spiritual awakening as the result of these steps, we tried to carry this message to others, and to practice these principles in all our affairs.

## Twelve Traditions—Al-Anon

The Traditions that follow bind us together in unity. They guide the groups in their relations with other groups, with A.A., and the outside world. They recommend group attitudes toward leadership, membership, money, property, public relations, and anonymity.

The Traditions evolved from the experience of A.A. groups in trying to solve their problems of living and working together. Al-Anon adopted these group guidelines and over the years has found them sound and wise. Although they are only suggestions, Al-Anon's unity and perhaps even its survival are dependent on adherence to these principles.

1. Our common welfare should come first; personal progress for the greatest number depends upon unity.
2. For our group purpose there is but one authority—a loving God as He may express Himself in our group conscience. Our leaders are but trusted servants—they do not govern.
3. The relatives of alcoholics, when gathered together for mutual aid, may call themselves an Al-Anon Family Group, provided that, as a group, they have no other affiliation. The only requirement for membership is that there be a problem of alcoholism in a relative or friend.
4. Each group should be autonomous, except in matters affecting another group or Al-Anon or AA as a whole.
5. Each Al-Anon Family Group has but one purpose: to help families of alcoholics. We do this by practicing the Twelve Steps of AA *ourselves*, by encouraging and understanding our alcoholic relatives, and by welcoming and giving comfort to families of alcoholics.

6. Our Family Groups ought never endorse, finance or lend our name to any outside enterprise, lest problems of money, property and prestige divert us from our primary spiritual aim. Although a separate entity, we should always co-operate with Alcoholics Anonymous.
7. Every group ought to be fully self-supporting, declining outside contributions.
8. Al-Anon Twelfth Step work should remain forever non-professional, but our service centers may employ special workers.
9. Our groups, as such, ought never be organized; but we may create service boards or committees directly responsible to those they serve.
10. The Al-Anon Family Groups have no opinion on outside issues; hence our name ought never be drawn into public controversy.
11. Our public relations policy is based on attraction rather than promotion; we need always maintain personal anonymity at the level of press, radio, films, and TV. We need guard with special care the anonymity of all AA members.
12. Anonymity is the spiritual foundation of all our Traditions, ever reminding us to place principles above personalities.

## Twelve Traditions—Alateen

Our group experience suggests that the unity of the Alateen Groups depends upon our adherence to these Traditions.

1. Our common welfare should come first; personal progress for the greatest number depends upon unity.
2. For our group purpose there is but one authority—a loving God as He may express Himself in our group conscience. Our leaders are but trusted servants; they do not govern.
3. The only requirement for membership is that there be a problem of alcoholism in a relative or friend. The teenage relatives of alcoholics, when gathered together for mutual aid, may call themselves an Alateen Group provided that, as a group, they have no other affiliation.
4. Each group should be autonomous, except in matters affecting other Alateen and Al-Anon Family Groups or AA as a whole.
5. Each Alateen Group has but one purpose: to help other teenagers of alcoholics. We do this by practicing the Twelve Steps of A.A. *ourselves* and by encouraging and understanding the members of our immediate families.
6. Alateens, being part of Al-Anon Family Groups, ought never endorse, finance or lend our name to any outside enterprise, lest problems of money, property and prestige divert us from our primary spiritual aim. Although a separate entity, we should always cooperate with Alcoholics Anonymous.
7. Every group ought to be fully self-supporting, declining outside contributions.

8. Alateen Twelfth Step work should remain forever nonprofessional, but our service centers may employ special workers.
9. Our groups, as such, ought never be organized; but we may create service boards or committees directly responsible to those they serve.
10. The Alateen Groups have no opinion on outside issues; hence our name ought never be drawn into public controversy.
11. Our public relations policy is based on attraction rather than promotion; we need always maintain personal anonymity at the level of press, radio, films, and TV. We need guard with special care the anonymity of all AA members.
12. Anonymity is the spiritual foundation of all our Traditions, ever reminding us to place principles above personalities.

## Twelve Concepts of Service

Carrying the message, as suggested in the Twelfth Step, is Service, Al-Anon's third legacy. Service, a vital purpose of Al-Anon, is action. Members strive to *do* as well as to *be*.

Anything done to help a relative or friend of an alcoholic is service: a telephone call to a despairing member or sponsoring a newcomer, telling one's story at meetings, forming groups, arranging for public outreach, distributing literature, and financially supporting groups, local services, and the World Service Office.

Read "Al-Anon's Twelve Concepts of Service" section for further information.

1. The ultimate responsibility and authority for Al-Anon world services belongs to the Al-Anon groups.
2. The Al-Anon Family Groups have delegated complete administrative and operational authority to their Conference and its service arms.
3. The right of decision makes effective leadership possible.
4. Participation is the key to harmony.
5. The rights of appeal and petition protect minorities and insure that they be heard.
6. The Conference acknowledges the primary administrative responsibility of the Trustees.
7. The Trustees have legal rights while the rights of the Conference are traditional.
8. The Board of Trustees delegates full authority for routine management of Al-Anon Headquarters to its executive committees.

9. Good personal leadership at all service levels is a necessity. In the field of world service the Board of Trustees assumes the primary leadership.
10. Service responsibility is balanced by carefully defined service authority and double-headed management is avoided.
11. The World Service Office is composed of selected committees, executives and staff members.
12. The spiritual foundation for Al-Anon's world services is contained in the General Warranties of the Conference, Article 12 of the Charter.

### ***General Warranties of the Conference***

In all proceedings the World Service Conference of Al-Anon shall observe the spirit of the Traditions:

1. that only sufficient operating funds, including an ample reserve, be its prudent financial principle;
2. that no Conference member shall be placed in unqualified authority over other members;
3. that all decisions be reached by discussion, vote, and whenever possible, by unanimity;
4. that no Conference action ever be personally punitive or an incitement to public controversy;
5. that though the Conference serves Al-Anon it shall never perform any act of government; and that like the fellowship of Al-Anon Family Groups which it serves, it shall always remain democratic in thought and action.

## **Optional Readings**

At this point in the meeting, groups may choose to read one or more of the “Optional Readings” (see page 23-27) or other selections from Al-Anon Conference Approved Literature.

## **Introductions**

The Chairperson invites members to introduce themselves. Members may choose to use their first name only or their entire name, according to their personal preference. The Chairperson may ask newcomers to identify themselves and welcomes them. (See “Welcoming New Members.”)

## **Announcements and Reports**

This is a time for announcement of local Al-Anon events, service meetings, and other group business, including day and time of business meetings, Treasurer’s report, and mail from the district, Area, or World Service Office. Reports may include:

- Group reports (Secretary, Treasurer, Group Representative, Intergroup Representative)
- District, Area, World Service Office
- Other Al-Anon/Alateen-related announcements

## **The Program**

Some groups have a Program Chairperson who presents the topic for group discussion; otherwise, the Chairperson introduces the speakers or the subject to be considered (see “Meeting Ideas”).

Large groups that may have divided into smaller sessions for the meeting discussion usually come back together at a given time for the Suggested Al-Anon/Alateen Closing.

## **Passing the Basket**

*At some point during the program, voluntary contributions are made following this statement by the Chairperson or Treasurer: “We have no dues or fees, but we do pass the basket to cover group expenses, including purchase of literature, support of our trusted servants, and Al-Anon service arms. According to our Seventh Tradition, Al-Anon/Alateen groups ought to be self-supporting through our own voluntary contributions. We are encouraged to contribute in gratitude for what Al-Anon/Alateen has given us. The amount is not important; what is important is that we give whatever we can.”*

[Note to Chairperson: While no one is required to contribute, the opportunity should be available to all, including newcomers.]



## Suggested Al-Anon/Alateen Closing

In closing, I would like to say that the opinions expressed here were strictly those of the person who gave them. Take what you liked and leave the rest.

The things you heard were spoken in confidence and should be treated as confidential. Keep them within the walls of this room and the confines of your mind.

A few special words to those of you who haven't been with us long: Whatever your problems, there are those among us who have had them, too. If you try to keep an open mind, you will find help. You will come to realize that there is no situation too difficult to be bettered and no unhappiness too great to be lessened.

We aren't perfect. The welcome we give you may not show the warmth we have in our hearts for you. After a while, you'll discover that though you may not like all of us, you'll love us in a very special way—the same way we already love you.

Talk to each other, reason things out with someone else, but let there be no gossip or criticism of one another. Instead, let the understanding, love, and peace of the program grow in you one day at a time.

Will all who care to, join me in closing with the \_\_\_\_\_ prayer?

*It is suggested that groups close in a manner that is agreeable to the group conscience. Many groups say the Al-Anon Declaration after their closing.*

## Al-Anon Declaration

*Let It Begin with Me*

When anyone, anywhere, reaches out for help,  
let the hand of Al-Anon and Alateen  
always be there, and—*Let It Begin with Me.*

# Optional Readings

The selections that follow are offered as suggestions for meeting topics or as optional readings in the group meeting format, as determined by the group conscience. They contain wisdom and information many members and groups have found helpful.

## **A. When newcomers or visitors are present, the group may want to read an explanation of anonymity, such as:**

“Members use their full names within the fellowship when they wish. The degree of anonymity a member chooses (first name, pseudonym, or full name) is not subject to criticism. Each member has the right to decide.

“Regardless of our personal choice, we guard the anonymity of everyone else in the fellowship, Al-Anon/Alateen and A.A. This means not revealing to anyone—even to relatives, friends, and other members—whom we see and what we hear at a meeting.

“Anonymity goes well beyond mere names. All of us need to feel secure in the knowledge that nothing seen or heard at a meeting will be revealed. We feel free to express ourselves among our fellow Al-Anons because we can be sure that what we say will be held in confidence.”

(From the section “Anonymity” in the “Digest of Al-Anon and Alateen Policies” section of the *Service Manual*. More information on anonymity both within and outside the fellowship can be found in this section.)

## **B. The Twelve Steps suggest acceptance of four primary ideas:**

**1. We Are Powerless Over the Problem of Alcoholism.** When we can honestly accept this truth, it brings us a feeling of release and hope. We can now turn our full attention to bringing our own lives into order. We can go forward to spiritual growth, to the comfort and peace to be gained from the entire program.

**2. We Can Turn Our Lives Over to a Power Greater Than Ourselves.** Now that our well-meant aid to the alcoholic has ended in failure and our own lives have become unmanageable, we realize we cannot deal with our problem objectively, perhaps not even sanely.

In Al-Anon we find a Power greater than ourselves which can direct our lives into quiet, useful channels. At first this power may

seem to be the group, but as we grow in knowledge and spiritual understanding, many of us call it God, *as we understand Him*.

**3. We Need to Change Both Our Attitude and Our Actions.** As we become willing to admit our defects, we begin to see how much of our thinking is distorted. We realize how unwise some of our actions have been, how unloving many of our attitudes. We try to recognize and correct these faults.

**4. We Keep Al-Anon's Gifts by Sharing Them with Others.** This sharing makes Al-Anon the vital, forward-reaching fellowship it is. Our great obligation is to those still in need. Leading another person from despair to hope and love brings comfort to both the giver and receiver.

**C. "Three Obstacles to Success in Al-Anon" is from the pamphlet, Alcoholism, the Family Disease (P-4).**

© Al-Anon Family Group Headquarters, Inc., Virginia, 2005. *This passage has helped many groups to resolve group problems.*

### Three Obstacles to Success in Al-Anon

All Al-Anon discussions should be constructive, helpful, loving, and understanding. In striving toward these ideals, we avoid topics that can lead to dissension and distract us from our goals.

1. **Discussions of Religion:** Al-Anon is not allied with any sect or denomination. It is a spiritual program, based on no particular form of religion. Everyone is welcome, no matter what affiliation or none. Let us not defeat our purpose by entering into discussions concerning specific religious beliefs.
2. **Gossip:** We meet to help ourselves and others learn and use the Al-Anon philosophy. In such groups, gossip can have no part. We do not discuss members or others, and particularly not the alcoholic. Our dedication to anonymity gives people confidence in Al-Anon. Careless repeating of matters heard at meetings can defeat the very purposes for which we are joined together.
3. **Dominance:** Our leaders are trusted servants; they do not govern. No member of Al-Anon should direct, assume authority, or give advice. Our program is based on suggestion, interchange of experience, and rotation of leadership. We progress in our own way and pace. Any attempt to manage or direct is likely to have disastrous consequences for group harmony.

**D. The following explanations have helped many newcomers and long time members understand the disease as well as how they have been affected. This text is from the Al-Anon pamphlet Understanding Ourselves and Alcoholism (P-48), © Al-Anon Family Group Headquarters, Inc., Virginia, 2009.**

## **Understanding Alcoholism**

### **What Is Alcoholism?**

The American Medical Association recognizes alcoholism as a disease that can be arrested but not cured. One of the symptoms is an uncontrollable desire to drink. Alcoholism is a progressive disease. As long as alcoholics continue to drink, their drive to drink will get worse. If not dealt with, the disease can result in insanity or death. The only method of arresting alcoholism is total abstinence. Most authorities agree that even after years of sobriety, alcoholics can never drink again, because alcoholism is a lifetime disease.

There are many successful treatments for alcoholism today. Alcoholics Anonymous is the best known, and widely regarded as the most effective. Alcoholism is no longer a hopeless condition, if it is recognized and treated.

### **Who Are Alcoholics?**

All kinds of people are alcoholics—people from all walks of life. Only a small percentage of alcoholics fit the stereotype of “derelict” or “bum” panhandling on the street. Most alcoholics appear to be functioning fairly well, but their drinking affects some part of their lives. Their family life, their social life, or their work may suffer. It might be all three. Alcoholics are people whose drinking causes a continuing and growing problem in any area of their lives.

### **Why Do Alcoholics Drink?**

Alcoholics drink because they think they have to. They use alcohol as a crutch and an escape. They are in emotional pain and use alcohol to kill that pain. Eventually they depend on alcohol so much that they become convinced they can’t live without it. This is *obsession*.

When some alcoholics try to do without alcohol, the withdrawal symptoms are so overwhelming that they go back to drinking because drinking seems to be the only way to get rid of the agony. This is *addiction*.

Most alcoholics would like to be social drinkers. They spend a lot of time and effort trying to control their drinking so they will

be able to drink like other people. They may try drinking on weekends or drinking only a certain drink. But they can never be sure of being able to stop drinking when they want. They end up getting drunk even when they promised themselves they wouldn't. This is *compulsion*.

It is the nature of this disease that alcoholics do not believe they are ill. This is *denial*. Hope for recovery lies in their ability to recognize a need for help, their desire to stop drinking, and their willingness to admit that they cannot cope with the problem by themselves.

## **Understanding Ourselves**

### **Families and Friends Are Affected**

Alcoholism is a family disease. Compulsive drinking affects the drinker and it affects the drinker's relationships. Friendships, employment, childhood, parenthood, love affairs, and marriages all suffer from the effects of alcoholism. Those special relationships in which a person is really close to an alcoholic are affected most, and we who *care* are the most caught up in the behavior of another person. We react to an alcoholic's behavior. Seeing that the drinking is out of hand, we try to control it. We are ashamed of the public scenes but try to handle it in private. It isn't long before we feel we are to blame and take on the hurts, the fears, and the guilt of an alcoholic. We, too, can become ill.

Even well-meaning people often begin to count the number of drinks another person is having. We may pour expensive liquor down drains, search the house for hidden bottles, or listen for the sound of opening cans. All our thinking becomes directed at what the alcoholic is doing or not doing and how to get the drinker to stop drinking. This is our *obsession*.

Watching fellow human beings slowly kill themselves with alcohol is painful. While alcoholics don't seem to worry about the bills, the job, the children, or the condition of their health, the people around them usually begin to worry. We often make the mistake of covering up. We try to fix everything, make excuses, tell little lies to mend damaged relationships, and worry some more. This is our *anxiety*.

Sooner or later the alcoholic's behavior makes other people angry. As we realize that the alcoholic is telling lies, using us, and not taking care of responsibilities, we may begin to feel that the alcoholic doesn't love us. We often want to strike back, punish, and make the

alcoholic pay for the hurt and frustration caused by uncontrolled drinking. This is our *anger*.

Sometimes those who are close to the alcoholic begin to pretend. We accept promises and trust the alcoholic. Each time there is a sober period, however brief, we want to believe the problem has gone away forever. When good sense tells us there is something wrong with the alcoholic's drinking and thinking, we still hide how we feel and what we know. This is our *denial*.

Perhaps the most severe damage to those of us who have shared some part of life with an alcoholic comes in the form of the nagging belief that we are somehow at fault. We may feel it was something we did or did not do—that we were not good enough, not attractive enough, or not clever enough to have solved this problem for the one we love. These are our *feelings of guilt*.

### **Help and Hope**

We who have turned to Al-Anon have often done so in despair, unable to believe in the possibility of change and unable to go on as we have before. We feel cheated out of a loving companion, overburdened with responsibilities, unwanted, unloved, and alone. There are even those of us who are arrogant, smug, self-righteous, and dominating. We come to Al-Anon, however, because we want and need help.

While we may have been driven to Al-Anon by the effects of someone else's drinking, we soon come to know that our own thinking has to change before we can make a new and successful approach to living. It is in Al-Anon that we learn to deal with our obsession, our anxiety, our anger, our denial, and our feelings of guilt. It is through the fellowship that we ease our emotional burdens by sharing our experience, strength, and hope with others. Little by little, we come to realize at our meetings that much of our discomfort comes from our attitudes. We begin to change these attitudes and learn about our responsibilities to ourselves. We discover feelings of self-worth and love, and we grow spiritually. The emphasis begins to be lifted from the alcoholic and placed where we do have some power—over our own lives.

***E. The group may choose to read other selections from Al-Anon Conference Approved Literature (CAL) as decided by the group conscience, with the source of the reading noted.***

# History: Al-Anon and Alateen

## How Al-Anon Family Groups Came to Be

The Family Group idea is nearly as old as Alcoholics Anonymous. In A.A.'s pioneering days from 1935 to 1941, close relatives of recovering alcoholics realized that to solve their personal problems they needed to apply the same principles that helped alcoholics with their recovery.

As early A.A. members and their wives visited A.A. groups throughout the country, the visiting wives told the mates of the newer A.A.s about the personal help received when they themselves tried to live by A.A.'s Twelve Steps, and how this helped to improve family relationships that often remained difficult even after the alcoholic had become sober.

Thus, mates and relatives of A.A. members began to hold meetings to discuss *their* common problems.

By 1948, numbers of Family Groups had applied to the A.A. General Service Office for listing in the A.A. Directory, and scores of relatives of alcoholics had asked them for help. But A.A. was designed to aid alcoholics only.

In 1951, two wives of A.A.s, Lois W. and Anne B., formed a Clearing House Committee to get in touch with these 87 inquirers and to coordinate, unify, and serve them; 56 groups responded. As a result of questionnaires, the name Al-Anon Family Groups was chosen. The Al-Anon name is simply a derivative of the first syllables of "Alcoholics Anonymous." The Twelve Steps of A.A., virtually unchanged, and later the Twelve Traditions were both adopted as guiding principles.

Soon the movement came to public attention. New groups and individuals here and abroad wrote to the Clearing House about their problems. By 1954, a small paid staff became necessary. The Clearing House was incorporated as a nonprofit organization under the name Al-Anon Family Group Headquarters, Inc.

In 1955, Al-Anon's first book, *The Al-Anon Family Groups, A Guide for the Families of Problem Drinkers*, was published. Since then many more books and pamphlets were added.

In 1961, Al-Anon initiated its annual World Service Conference of Delegates, WSO staff, and volunteers to act as the fellowship's

overall conscience. In the quarter century from 1951 to 1976, over 12,000 groups in the United States, Canada, and many lands overseas were added to the original 56. In 2001, the WSO started registering on-line meetings, and in 2007, other electronic meetings.

By 2012 there were over 25,000 groups in 133 countries and 107 electronic (Internet and telephone) meetings.

## How Alateen Came to Be a Part of Al-Anon Family Groups

Teenage children in the families of alcoholics soon realized that their problems differed from those of adult members. In 1957, Alateen grew out of this need. A 17-year-old boy, whose father was in A.A. and mother in Al-Anon, had been fairly successful in trying to solve his problems by applying the A.A. Steps and slogans.

With his parents' encouragement, he asked five other teenagers with alcoholic parents to join him in forming a group to help other teenagers. The idea caught on, and the number of groups began to grow.

In response to articles distributed by the WSO, 10 new Alateen groups were registered, and by 1958, the Board of Directors announced 31 new Alateen groups, with 39 more proposed, and its decision to establish an Alateen Committee.

In 1957, *Youth and the Alcoholic Parent* was submitted by California Alateen groups for publication. Subsequently, several books and pamphlets were produced as well as a newsletter, *Alateen Talk*, and the video *Alateen Tells It like It Is* (no longer sold).

By the end of 1962, there were 203 registered groups, and the Alateen program was spreading to other countries. In April of 1964, a staff member was added to work for Alateen, to handle correspondence with members and groups, send free packets of literature to new groups, and respond to inquiries from concerned professionals.

In 2003, the Al-Anon Family Group Headquarters, Inc. Board of Trustees took action to assure the safety of Alateens and Al-Anon Members Involved in Alateen Service. The 2003 Alateen Motion from the Board of Trustees required that all Al-Anon Areas in the World Service Conference (WSC) Structure establish Area Alateen Safety and Behavioral Requirements, and have a process for certification of Al-Anon Members Involved in Alateen Service (AMIAS).

In 2012, there were numerous Alateen pamphlets, leaflets, and books; a quarterly newsletter, *Alateen Talk*; and service materials for Alateen Group Sponsors. There are over 1,700 Alateen groups worldwide.



# How to Start a Group

In the World Service Conference structure, all Alateen groups are registered through their Area's Alateen Process. (See "Starting an Alateen Group" and "Alateen Policies.") In other structures, members should contact their national office.

## Starting an Al-Anon Family Group

### *Tradition Three*

*The relatives and friends of alcoholics, when gathered together for mutual aid, may call themselves an Al-Anon Family Group, provided that, as a group, they have no other affiliation. The only requirement for membership is that there be a problem of alcoholism in a relative or friend.*

If there is no Al-Anon group in your community, you may start one, along with one or two other people who need and want Al-Anon's help. Any two or more relatives or friends of alcoholics who meet to solve their common problems may call themselves an Al-Anon group, provided they have no other affiliation as a group. For more information see the Guidelines *Starting an Al-Anon Group* (G-12), *Starting an Alateen Group* (G-19), and/or contact the World Service Office or national service structure.

### **Reasons for Registration**

- Registration with the WSO is important as it provides, through the World Service Conference, a link to worldwide Al-Anon and Alateen that assures unity of purpose and a common bond of love and friendship available to each member, no matter where they may travel.
- The WSO provides meeting information (to newcomers and others) about registered groups, to carry out Al-Anon's one purpose: to help families and friends of alcoholics.
- Registered groups are connected to the worldwide fellowship through communications sent via e-mail and postal mail from the WSO.

### **WSO Registration Process \***

The procedure is simple:

- Decide on a group meeting place, day, and time.
- Review the Guideline *Starting an Al-Anon Meeting* (G-12).

*\*In other countries outside the World Service Conference structure, services to new groups vary.*

- Contact your District Representative or Area Group Records Coordinator to obtain information on the Area group registration process. (The WSO Al-Anon Group Registration/Change Form [GR-1] and instructions on how to complete the form are posted on the Al-Anon/Alateen Members' Web site.)
- Return the completed GR-1 form through your Area process or to the WSO via e-mail, fax, or postal mail.

The WSO will register a group with the understanding that the group will abide by the Al-Anon Traditions and not affiliate with or endorse any outside entity or practice. Joint meetings for Al-Anon and A.A. members, meetings comprised of only A.A. members, and groups that practice specific therapies, such as guided meditation, are not in keeping with Al-Anon principles and do not qualify to be registered as an Al-Anon group.

Once the WSO reviews the completed GR-1, it assigns a group ID number and sends a packet containing introductory materials to the group's Current Mailing Address (CMA). (See "Things to Consider when Starting an Al-Anon or Alateen Group.")

After the WSO registration process is completed, the group is encouraged to connect with their Area Group Records Coordinator or local district to find out the process for inclusion in the local meeting directory and on the Area Web site. Some Areas and AISs may require a second, separate registration form.

Prospective groups may contact the World Service Office for further information and/or to request that the information be sent via postal mail.

## Starting an Alateen Group

Where Al-Anon is firmly established, groups may want to help the younger members of the Al-Anon family by starting an Alateen group through the Area's Alateen process. Alateen groups are usually started at the suggestion of an Al-Anon or A.A. member, a professional, school personnel, or the teenagers themselves. Alateen groups require Alateen Group Sponsors who are currently certified through their Area's Alateen process as Al-Anon Members Involved in Alateen Service (AMIAS), and meet all Area requirements for service to Alateen. Al-Anon members who are also members of A.A. and meet their Area's certification requirements may sponsor Alateen meetings by virtue of their Al-Anon membership. Anonymity regarding other programs is maintained in the Alateen meeting, just as it would be in any Al-Anon meeting. Alateen is an integral

part of Al-Anon, thus emphasis is placed at all times on the Al-Anon/Alateen interpretation of the program.

Parents who are currently certified through their Area Alateen process may serve as Alateen Group Sponsors; however, whenever possible, it is preferred that the Sponsor not be a relative of any of the Alateen members attending the Alateen group.

The Guidelines *How to Start an Alateen Meeting* (G-19) and *Alateen Safety Guidelines* (G-34) are available on the Members' Web site. (See also "Alateen Policy" in the "Digest of Al-Anon and Alateen Policies" section of the *Al-Anon/Alateen Service Manual* [P-24/27].)

### **How to Start an Alateen Group**

When the World Service Office is contacted about starting an Alateen meeting, the WSO thanks the caller or writer for his/her interest and explains that Alateen meetings require Alateen Group Sponsors who have completed the Area's Alateen certification process as an Al-Anon Member Involved in Alateen Service (AMIAS). Al-Anon members will be referred to their Area Alateen Coordinator for information on the Area process for AMIAS certification and group registration.

If the caller is not an Al-Anon member, the WSO mails an Alateen information packet to the caller with the information that a local Al-Anon member will be in contact within a few weeks. The WSO contacts the Area Alateen Coordinator for this follow-up.

Alateen groups do not meet or appear on local meeting schedules until the registration process is complete.

Alateen Group Registration/Change forms and Al-Anon Member Involved in Alateen Service (AMIAS) forms are distributed by the Area and submitted to the WSO through the Area's Alateen process. When the WSO receives a new Alateen group registration form from the Area, the WSO registers the group and assigns a WSO group number. The group is added to the mailing list for complimentary WSO publications. These publications, including *Alateen Talk* and other WSO mailings, are sent to the group's Current Mailing Address (CMA) that was listed on the group registration form. (See "CMA.")

The WSO toll-free meeting line may refer prospective members to the group. Contact information may be given to callers who request specific information about the meeting such as directions, what door to use, age range of the Alateens, etc. Phone contacts and Alateen group CMAs are Alateen Group Sponsors or other Area-certified AMIAS. It is important that the group keep its Area up-to-date on any changes in the group information. Alateen group changes are submitted to the WSO through the Area's Alateen process.

It may be difficult for an Alateen group to be financially fully self-supporting at first. Financial support for group expenses such as literature, refreshments, and rent may be provided by Al-Anon group(s), but only until the Alateen group is able to meet its own expenses. Some teens may not have a lot of money, but the spiritual act of contributing reinforces the idea of belonging as a member.

Some Alateen group meetings are held at schools during school hours, and are attended only by students from the school. Alateen Group Sponsors at these limited-access meetings must also be certified through the Area Alateen process, as well as meet the school's safety requirements. More information on school meetings is available in the *Alateen Meetings in Schools* Guideline (G-5), *Information for Educators: Alateen Meetings in Schools* leaflet (S-64), and the "Alateen Policy" section in the "Digest of Al-Anon and Alateen Policies" section of the *Al-Anon/Alateen Service Manual* (P-24/27).

Anyone wanting to start an Alateen meeting outside of the World Service Conference structure is directed by the WSO to that country's national service committee or General Service Office (GSO), if one exists.

See also "Things to Consider when Starting an Al-Anon or Alateen Group."

### ***The Alateen Meeting***

Groups that meet each week are apt to be more firmly established from the outset, particularly when the Alateen members communicate with one another between meetings. Weekly meetings give members more frequent opportunity to share how they are working the program and applying it to their daily lives.

**Alateen meetings are closed meetings.** Ordinarily only Alateens and the Area-certified Alateen Group Sponsors attend; however designated Area trusted servants may occasionally attend the meeting as a resource to the group per the Area's Alateen Safety and Behavioral Requirements. All Alateen Group Sponsors, even temporary or substitute Sponsors, must be certified through their Area Alateen process before being of service to Alateen. When a regular Alateen Group Sponsor is not available, another Al-Anon member who has been certified through the Area's Alateen process can serve as an Alateen Group Sponsor. When there are no certified Al-Anon members available to be of service to the Alateen group, the Alateens are always welcome to attend an Al-Anon meeting.

Alateen groups may hold an occasional (annual, bi-annual, or quarterly) open meeting to celebrate the group anniversary, to inform

professionals or others about Alateen, or for another special occasion. Open meetings may have one or more speakers that explain how the Al-Anon/Alateen program works.

## Things to Consider When Starting an Al-Anon or Alateen Group

### **CMA (Current Mailing Address)\***

It is essential to be able to contact the group. Each group needs to have someone who is willing to receive mail, and take it to the group. The CMA is a member who agrees to accept and deliver the group's mail (postal and electronic), anticipates keeping the same address for at least a year, and who attends the group's meeting regularly. The CMA may be, but does not have to be, the Group Representative (GR) or another group officer. Some groups rent a post office box, and members rotate the responsibility to deliver the mail to the group.

Up-to-date CMA information assures the group of promptly receiving all mail. The WSO and the local service arms are to be notified immediately when the CMA changes, so there will be no disruption of service to the group.

On the WSO group registration form (GR-1), groups are asked to provide a phone number and e-mail address for the CMA. E-mail is used for time-sensitive communications with the group and to distribute the monthly newsletter, *Group e-News*. Members who do not have access to e-mail may choose to have an "e-buddy" to receive the group's mail. (See "Anonymity Within Al-Anon/Alateen" in the "Digest of Al-Anon and Alateen Policies" section of the *Al-Anon/Alateen Service Manual* [P-24/27].)

### **Phone Contacts\***

The WSO group registration form also asks for one or two phone contacts. These members agree to receive calls from newcomers seeking Al-Anon's help, or from traveling members seeking information about the group's meeting, directions, etc. The paid staff who answer the WSO toll-free meeting line\*\* will give the location and time of the group's meeting, as well as the contact's first name and phone number, if the caller wants more information. In keeping with Tradition Eight, WSO paid staff do not do Twelfth Step work.

\***Alateen Safety Note:** *To protect our Alateens, only Al-Anon Members Involved in Alateen Service (AMIAS), certified through their Area process, can be listed as an Alateen group CMA or as the Alateen group phone contacts*

\*\* *For meeting information for the U.S., Canada, Puerto Rico, and Bermuda only: call (888) 425-2666 (888-4-AL-ANON).*

## Where to Hold Group Meetings

Al-Anon and Alateen group meetings are usually held weekly in a place that is welcoming to all, such as a clubroom, hospital meeting room, an institution, library, a religious facility, a school building, or any other suitable place. When meeting in a public place is not an option for a group, as it is in some countries, a group may temporarily meet at the home of a member. (See the “Digest of Al-Anon and Alateen Policies” section of the *Al-Anon/Alateen Service Manual* [P-24/27] for descriptions of introductory meetings and limited-access facilities.)

## Naming the Group

### Tradition Four

***Each group should be autonomous, except in matters affecting another group or Al-Anon or AA as a whole.***

A group’s name is often included in meeting directories (both printed and on-line) and may be a potential member’s first impression of Al-Anon/Alateen. Therefore, having an appropriate group name is very important. A name that includes the town or section of the town, the meeting day, a slogan, or another phrase from our program is inviting to all and conforms to Al-Anon/Alateen principles. As stated in Tradition Eleven, “Our public relations policy is based on attraction rather than promotion...” A group would be *promoting* Al-Anon if the group name appeared to offer promises, guarantees, personal advice, or gave the impression that the meeting has experts who know what is best for all family members and friends of alcoholics.

A group’s name should not imply affiliation with any other organization, including A.A. or any Twelve Step group, self-help group, commercial venture, agency, religious or rehabilitation facility, philosophy, religious principle or belief, or any outside literature or enterprise. To help avoid confusion, it is suggested that groups spell out the group’s complete name including any specific format or designation. Nicknames or attempts at humorous names may turn away or confuse potential members. In the spirit of our primary purpose of being welcoming and giving comfort to families and friends of alcoholics, such names are to be avoided.

Things to discuss when choosing a group name include:

- How is this name reflective of Al-Anon’s principles?
- Is the name inviting to potential members? Could it be confusing or offensive to potential members?
- Does the name imply a promise, requirement for attending, or an affiliation with an entity outside of Al-Anon?

Some relatives and friends of alcoholics find it easier to address their common problems in dealing with the effects of someone else's drinking with those in similar life situations. These members have formed Al-Anon groups for men, women, parents, adult children, and gays and lesbians (LGBT). The group may include these designations in its group name, with the understanding that, as with all Al-Anon groups, membership remains open to anyone affected by someone else's drinking. Members of these groups are encouraged to attend other Al-Anon meetings as well.

The WSO reviews new group names for adherence to these guidelines and may ask a group to choose another name if it is not in keeping with Al-Anon/Alateen principles. (See also "Group Names" in the "Digest of Al-Anon and Alateen Policies" section of the *Al-Anon/Alateen Service Manual* [P-24/27].)

As the group's Current Mailing Address (CMA) is often a member's home, to protect the CMA's anonymity, all Al-Anon groups are registered with the letters AFG (for Al-Anon Family Group).

### **Meeting Type: Open/Closed Meetings**

All Al-Anon Family Group meetings welcome anyone who believes that his/her life has been affected by someone else's drinking, either today or in the past. An Al-Anon meeting may choose to be "**open**" or "**closed**" by the consent of its participants.

**Open** Al-Anon meetings allow attendance by people who are not families and friends of alcoholics, but who are interested in learning about Al-Anon Family Groups. People who may come to open Al-Anon meetings occasionally include students and professionals who work with alcoholics and their families.

Generally, Al-Anon group meetings are "**closed**," limited to members and prospective members, giving them the freedom to share and listen to the experience, strength, and hope of one another on a confidential and anonymous basis.

A meeting registered as closed may choose to make one or more of its meetings open to the public, to ensure that those interested in Al-Anon can find an open meeting. Should an observer show up at a closed meeting, members can take a quick group conscience on whether to allow them to sit in. Such visitors should be treated with courtesy and respect for showing an interest in our fellowship.

Observers attending open Al-Anon meetings are requested to abide by the principles that guide participation in all Al-Anon Family Group meetings, most especially the principles of confidentiality and

anonymity that protect its members. Al-Anon and Alateen members should exercise care in what they share at an open meeting.

**All Alateen meetings are closed;** ordinarily only the Alateen members and the Area-certified Al-Anon Members Involved in Alateen Service (AMIAS) who are serving as the Alateen Group Sponsors attend. However, designated Area trusted servants may occasionally attend the meeting as a resource to the group, per the Area's Alateen Safety and Behavioral Requirements. (See "The Alateen Meeting" and the "Alateen Policies" section of the "Digest of Al-Anon and Alateen Policies.")

### ***Beginners' Meetings***

Beginners' meetings are an important part of Al-Anon Family Groups. Experienced Al-Anon/Alateen members introduce newcomers to the Al-Anon program, as well as inform them about alcoholism as a disease with far-reaching effects. Newcomers are given the opportunity to discuss their feelings with long-time members.

These meetings may focus on the first three Steps to introduce newcomers to our program and acquaint them with various basic pieces of literature. Beginners' meetings may be held as a series.

Some Al-Anon groups offer beginner topics as a way to attract newer members to attend. These groups are registered as regular Al-Anon groups and have a Group Representative. They may use "Beginner" as part of their group name.

Other groups may decide to hold special beginners' meetings in conjunction with the regular group meeting, to provide newcomers with a simple introduction to Al-Anon. These beginners' meetings are served by the Group Representative of the hosting Al-Anon group, and do not register as a separate group. There is a space on the Al-Anon Group Registration/Change form (GR-1) to indicate if a group offers such a beginners' meeting.

Guidelines and newcomer materials are available for beginners' meetings. The *Beginners' Meeting* Guideline (G-2) is posted on the Al-Anon/Alateen Members' Web site, and can be downloaded and printed as needed for members' use.

### ***Multiple Meetings***

While the majority of new meetings are registered as separate groups, multiple meetings are considered as one group meeting at different times at the same location. In order to make an informed decision, groups should thoroughly discuss the advantages as well as the disadvantages of registering multiple meetings. Meetings



that register as separate groups are each eligible to have their own Group Representative, receive WSO, Area, and local mailings, and have their own group number, Current Mailing Address (CMA), and contacts. Meetings that register as multiple meetings of one group share the same name, CMA, and contacts. Multiple meetings share a Group Representative and WSO mailings.

It is important that groups with multiple meetings hold regularly-scheduled business meetings so that members from all of the meetings are able to share information and participate in making group decisions. (See “Group Business Meetings.”)

A meeting that is initially registered as a multiple meeting of a group may later decide, by a group conscience decision of the members of that meeting, to re-register as a separate group.

### ***Getting the Meeting Started***

- Carefully review all the materials you have received.
- Decide who will fill the positions necessary to begin, such as CMA, Chairperson, and Secretary/Treasurer.
- Work out the details of your meeting format as a group.

### **Starting an Electronic Al-Anon Meeting (On-line and Telephone)**

Al-Anon Family Groups acknowledge the potential and value of the Internet, telephone, and other electronic communications media for communicating information about Al-Anon and offering hope and comfort to the families and friends of alcoholics. Electronic meetings can introduce Al-Anon Family Groups to the potential newcomer and those without access to a local group. Al-Anon electronic meetings are held via numerous electronic media, including on-line (voice and written), and telephone. In keeping with the spiritual principle of maintaining personal anonymity in the media (as expressed in Tradition Eleven), Al-Anon and Alateen meetings are not held on social networking sites.

Al-Anon does not endorse, oppose, or lend support to any on-line service provider, telephone service provider, or specific communication devices. All electronic meetings are registered with the WSO, regardless of language or structure. For safety reasons, the WSO does not currently register electronic Alateen meetings that are not administered by the WSO.

The WSO will register an electronic meeting with the understanding that it will abide by the Traditions and that meetings will be open

to any Al-Anon member or prospective member. Each meeting is registered separately and assigned its own WSO ID number.

The basics needed to start an Al-Anon electronic meeting are:

- Review the *Fact Sheet for Al-Anon Electronic Meetings* (S-60) and the *Electronic Al-Anon Meeting Guideline* (G-39). Both are posted on the Al-Anon/Alateen Members' Web site, along with the Electronic Meeting Registration/Update Form.
- Determine what type of meeting you want to start—on-line (voice and written), telephone, or other electronic media.
  - On-line meetings can have only one feature: e-mail, chat, or message board.
  - Telephone meetings have a phone number and access code.
- Determine what service provider to use.
- Decide on a day and time to meet (if real time).
- Return the Al-Anon Electronic Meeting Registration Form, with CMA and contact information, to the WSO.
- Contact the WSO with any questions.

## Initial Group Service Positions

The organization of a group should be kept simple.

A **small group** needs a CMA (Current Mailing Address), Chairperson, and a Secretary; the latter often acts as Treasurer until the group is large enough to elect one. One or two members agree to be listed as group contacts to take Twelfth Step calls from newcomers. (See “Phone Contacts.”)

**As membership in the group grows**, additional service opportunities can be added such as Treasurer, Group Representative (GR), Literature Chairperson, someone in charge of hospitality, greeters, and other positions as suggested by the group conscience.

**Large groups** may choose to have a Program Chairperson, Business or Steering Committee, and Information Service Representative (ISR) in addition to other positions as suggested by the group conscience. When possible, alternates are elected for all positions.

(See details of these trusted servants' duties in the section “Suggested Duties of Group Officers/Leaders.”)

# Basics for Group Meetings

## Membership

### *Tradition Three*

*The relatives of alcoholics, when gathered together for mutual aid, may call themselves an Al-Anon Family Group, provided that, as a group, they have no other affiliation. The only requirement for membership is that there be a problem of alcoholism in a relative or friend.*

Al-Anon and Alateen membership is open to anyone who feels his or her life has been affected by someone else's drinking, either currently or in the past. In keeping with Tradition Three, all family members and friends of problem drinkers are welcome to attend Al-Anon meetings in order to decide for themselves whether Al-Anon can benefit them. New members are encouraged to attend different meetings, to find groups where they feel most comfortable.

### **Membership in an Al-Anon/Alateen Group**

Members join local groups where the Al-Anon/Alateen program is shared and where members participate in group service. Al-Anon and Alateen members usually consider one group as their "home group." By regular attendance, friendships are established, and growth is acknowledged. In a home group, members find a place where they are loved and accepted, no matter what.

A home group encourages personal and group growth by offering a variety of service opportunities within the group, and connects its members to the worldwide fellowship through service in the district, Area, and world services.

## Sharing in Al-Anon/Alateen Meetings

### *Tradition One*

*Our common welfare should come first; personal progress for the greatest number depends upon unity.*

In group meetings, we share our own experience, strength, and hope, keeping the focus on ourselves and how the Al-Anon/Alateen program has helped us change our attitudes and actions. Our discussions center on solutions for our own difficulties. We try not to tell other people's stories or repeat what we see or hear, always protecting one another's anonymity and the anonymity of Al-Anon, Alateen, and A.A. members, as well.

We concentrate on our own feelings and attitudes, rather than on the details of our situation. Members leave other affiliations (such as

other Twelve Step programs or professional resources) outside our meeting rooms.

It is suggested that Al-Anon/Alateen members avoid discussion of specific religious beliefs or ideas, criticism of one another or the alcoholic, gossip, or revealing intimate details of their problems. More detailed discussion may take place between meetings in private conversations with another member, or a personal Sponsor. (See “Three Obstacles to Success in Al-Anon” and “Sponsorship” in the *Al-Anon/Alateen Service Manual* [P-24/27].)

## Welcoming New Members

The newcomer to Al-Anon/Alateen is often nervous, lonely, and usually desperate. In addition to the help, guidance, and literature provided by the group, individual attention and the friendship of an established member can be of great help. New members may have had personal contact with a member before their first meeting.

If a group has a beginners’ meeting, newcomers to Al-Anon/Alateen are encouraged to attend. After the new members have attended a number of regular meetings, group members encourage them to express themselves, ask them to read aloud the Serenity Prayer, the Suggested Preamble, or in some small way take part in the group functions so they will feel they belong.

Where there is no beginners’ meeting, members can briefly share their experience, strength, and hope; provide the newcomers with Conference Approved Literature (possibly a *Newcomer Packet* [K-10]); urge them to read the material; and share with them the value of using the program to cope with problems.

It is helpful to provide new members of the group with an explanation of the group’s meeting format, method of sharing, and that in Al-Anon meetings, members refrain from discussing specific religious tenets, therapies, and other affiliations.

It is also helpful to keep in touch with the new members between meetings.

For more information, see the *Guideline Beginners’ Meetings* (G-2).

## Anonymity

### *Tradition Twelve*

***Anonymity is the spiritual foundation of all our Traditions, ever reminding us to place principles above personalities.***

Anonymity in Al-Anon is a sacred trust, basic to our fellowship and its survival.

The principle of anonymity is essential during meetings to assure the confidentiality of who is present and what is shared at the meetings. In time some members become willing to share their full names within the fellowship in order to serve it. As time progresses some members decide to let their membership in Al-Anon be known to professionals in the community so others can receive Al-Anon's help. Each member chooses when and why he or she lets others outside their meeting know he or she is attending Al-Anon. The principle of anonymity encourages each member to respect the reasons for this personal decision and make no judgments about them.

**Special Note:** Anonymity is a spiritual principle and cannot be used as a legal basis to shield criminal behavior, past or current. It is wise to remember that Al-Anon and Alateen meetings are not above the law. Members need to exercise care in sharing information that could require reporting to local, state, provincial, and national authorities.

### **Tradition Eleven**

***Our public relations policy is based on attraction rather than promotion; we need always maintain personal anonymity at the level of press, radio, films, and TV. We need guard with special care the anonymity of all A.A. members.***

The principle of anonymity acts as a restraint on members at the public level to assure that no one will use Al-Anon for profit, prestige, or power. This means that at the level of press, radio, films, TV, and the Internet, full names and faces of Al-Anon and Alateen members would not be used. No Al-Anon member can speak as an authority on Al-Anon in the media. No one's story is more important than others. We are a fellowship of equals and Al-Anon is a program of principles, not personalities.

At open Al-Anon meetings, group anniversaries, conventions, or workshops where non-members are present, Al-Anon and Alateen members are free to decide how much anonymity they prefer. It is well to open such meetings with a brief explanation of the Eleventh and Twelfth Traditions. One suggestion is as follows:

There may be some who are not familiar with our Tradition of personal anonymity in any form of press, radio, films, TV, Internet, and other electronic media.

If so, we respectfully ask that no Al-Anon, Alateen, or A.A. speaker or member be identified by full name or picture in published, broadcast, or Web-posted reports of our meeting.

The assurance of anonymity is essential to our efforts to help other families of alcoholics, and our Tradition of anonymity reminds us to place Al-Anon and Alateen principles above personalities.

Event planners may want to make a further note about anonymity and picture-taking. Here is one suggested statement:

Out of respect for others, please do not take photographs during any of the meetings at this event. Please be considerate when taking photographs, using care that you do not capture images of Al-Anon, Alateen, A.A. members, or their guests who did not give their permission and may not wish to appear in your pictures. In the spirit of Tradition Eleven, please do not post recognizable photos of identifiable Al-Anon, Alateen, A.A. members, or their guests on Web sites accessible to the public, including unrestricted pages on social networking sites.

See “Anonymity” in the “Digest of Al-Anon and Alateen Policies” section of the *Al-Anon/Alateen Service Manual* (P-24/27) for more information on the principle of anonymity.

## Meeting Ideas

There is no rigid formula for an Al-Anon or Alateen meeting. The general pattern is to have the Chairperson or leader open and close the meeting, announce the meeting topics, or introduce guest speakers or members who share their experience, strength, and hope as a result of working the Al-Anon program. Experience suggests that more can be accomplished when members share on a single topic during the meeting and all members have the opportunity to share.

### **Discussion Meetings**

The Chairperson or leader presents an Al-Anon or Alateen topic to help members focus on their thoughts and discuss the subject as it applies to them. Topics may include:

- **Twelve Steps:** It is suggested that one of the Steps be covered in at least one meeting per month. The Chairperson or leader usually reads the Step and may read a passage from the books *Al-Anon’s Twelve Steps & Twelve Traditions* (B-8), *How Al-Anon Works for Families & Friends of Alcoholics* (B-22), or *Paths to Recovery—Al-Anon’s Steps, Traditions, and Concepts* (B-24), the workbook *Reaching for Personal Freedom—Living the Legacies* (P-92), or from an issue of *The Forum*. The Steps

also appear in many other Al-Anon publications. Members may then comment on the Step and how it applies to their situation.

- **Twelve Traditions:** The group studies one or more of the Traditions and their value in maintaining group harmony and growth, keeping in mind the goal of Al-Anon unity worldwide. The procedure for a Tradition meeting and the sources of material, for the most part, are the same as those for a Step meeting.
- **Twelve Concepts of Service:** A better understanding of Al-Anon World Services and the application of these principles to our personal lives can be obtained by study of the Twelve Concepts of Service, found in the *Service Manual*, the books *How Al-Anon Works for Families & Friends of Alcoholics* (B-22), *Paths to Recovery—Al-Anon’s Steps, Traditions, and Concepts* (B-24), the workbook *Reaching for Personal Freedom—Living the Legacies* (P-92), and the pamphlet *The Concepts—Al-Anon’s Best Kept Secret?* (P-57).
- **Al-Anon Slogans:** One or more of the slogans may serve as the basis of a discussion of their value in daily living. They appear in the book *How Al-Anon Works for Families & Friends of Alcoholics* (B-22) and throughout our books, literature, and *The Forum*, as they also help us deal with our day-to-day personal situations.
- **Panel Discussions:** Members present are invited to write and submit questions, anonymously, if so desired, to a panel of two or three members chosen by the Chairperson or leader to share their experiences in handling these situations. This may also open informal discussion by the entire group; the Chairperson, by limiting each person to one or two minutes, can make sure that no one monopolizes the discussion.
- **Literature Meetings:** An unlimited supply of topics can be found in Al-Anon Conference Approved Literature. Many groups allot one meeting a month to a discussion of a particularly interesting subject from the current issue of *The Forum*, Al-Anon/Alateen’s monthly magazine. *The Forum* is a Conference approved publication for use in meetings, presenting meeting topics and personal stories for group discussions. Members may also discuss the optional readings in the “Meeting Format” section.

## Speaker Meetings

- **Personal Stories:** Two or three Al-Anon or Alateen members may be asked to speak at the meeting, to tell how the Al-Anon program helps them in their daily living.
- **A.A. Speaker:** An occasional talk by an A.A. member often presents insights into the disease of alcoholism from the viewpoint of an alcoholic.
- **Exchange Meeting:** An individual or a team of speakers from another group, including Alateen, may care to exchange speakers with your group.
- **Special Event:** Occasions such as group anniversaries may serve as an invitation to the Al-Anon program by featuring Al-Anon or Alateen speakers whose personal stories of recovery through the Al-Anon program can give strength and hope to those who hear them.
- **Outside Speakers:** Individuals from the community may occasionally be invited to address an Al-Anon/Alateen meeting. Those selected should be knowledgeable about alcoholism; however, having professional speakers too often at Al-Anon/Alateen meetings may divert us from our own recovery program.

## Beginners' Meetings

When newcomers are present, the group may spend some or all of the meeting time welcoming the newcomer by having one or more members share their reasons for coming to Al-Anon and how it has helped them. Some beginners' meeting topics might be discussion of one of the first three Steps, detachment, the Serenity Prayer, or a slogan. The *Beginners' Meeting* Guideline (G-2) is posted on the Members' Web site.

## Group Inventory Meeting

A group inventory may be held during the regular meeting time or at a time convenient to most members. An inventory may be based on the Guideline *Taking a Group Inventory* (G-8a & G-8b), posted on the Al-Anon/Alateen Members' Web site. See also "Group Business."

## Public Outreach Meeting

The function and usefulness of Al-Anon/Alateen can be explained to a wider audience if an open meeting is planned at which members, their relatives and friends, A.A. members, students, and professionals are welcome. A meeting held to celebrate a special occasion is usually open. See the Guidelines *The Open Al-Anon Meeting* (G-27) and *A Meeting on Wheels* (G-22).



# Group Service Positions

## *Tradition Two*

*For our group purpose there is but one authority—a loving God as He may express Himself in our group conscience. Our leaders are but trusted servants—they do not govern.*

## **Suggested Duties of Group Officers/Leaders**

Group officers rotate regularly. Rotation gives all members the privilege of serving. Officers/leaders are trusted servants; they do not govern the group. Groups may attain more participation by electing alternates to the group service positions.

### **Chairperson/Leader:**

- Plans meetings in advance with the Program Chairperson. (See “Meeting Ideas.”)
- Opens the meeting by reading the Preamble or the Welcome and leads the group in reciting the Serenity Prayer; follows the group’s meeting format.
- Introduces speakers or announces the subject of the meeting.
- Invites members to take part.

### **Program Chairperson:**

- Asks a member to chair the meeting.
- Plans meetings. (See “Meeting Ideas.”)

### **Secretary:**

- Handles group correspondence.
- Notifies their Area Group Records Coordinator or the WSO of any changes of the group, GR, and/or CMA, as well as phone numbers of group contacts.
- May pick up the mail from the post office box (if applicable) or serves as the CMA (Current Mailing Address).
- Keeps an up-to-date list of members, and their phone numbers.
- Makes necessary Al-Anon-related announcements at meetings.
- Orders Conference Approved Literature in sufficient quantities to supply the group’s needs (if the group does not have a Literature Chairperson).
- Encourages support of Alateen by providing information regarding Al-Anon Members Involved in Alateen Service (AMIAS) certification until the group elects a Group Representative.

**Treasurer:**

- Maintains the group's financial records in a manner that reflects the group conscience. Some groups have an actual budget that includes periodic contributions to the district, local Al-Anon Information Service, Area Assembly, and World Service Office. (See "Group Finances/Budget.")
- Passes the collection basket at group meetings.
- Asks another member to help count and record the collection.
- Reads the Quarterly Appeal Letter, and passes around the accompanying collection envelope to the group at two consecutive meetings.
- Submits a financial statement to the group at regular intervals.

**CMA (Current Mailing Address):**

- Receives postal and electronic group mail.
- Brings the mail to the group. (See "Things to Consider when Starting an Al-Anon or Alateen Group.")

**Group Phone Contact:**

- Receives calls from newcomers seeking Al-Anon's help or others seeking directions or additional information about the meeting.

**Group Representative\* (GR):**

- Acts as liaison between the group and the district and between the group and the Assembly.
- Familiarizes themselves with the current copy of the *Al-Anon/Alateen Service Manual* (P-24/27), and encourages its use among group members.
- Works through the district in helping to initiate public outreach projects.
- Encourages Alateen sponsorship in accordance with Area Alateen Safety and Behavioral Requirements.
- Serves as local representative of the Al-Anon/Alateen magazine, *The Forum*, by:
  - Acquainting members with its usefulness.
  - Suggesting personal subscriptions.
  - Submitting group subscriptions to the WSO.
  - Encouraging members to write articles.

\* Al-Anon and Alateen members who are also members of A.A. may not serve as GR or Alternate GR. See "Digest of Al-Anon and Alateen Policies," Dual Membership in Al-Anon/Alateen and A.A.

- Is elected for a three-year term.
- Encourages election of an Alternate GR.

**Information Service Representative\* (ISR):**

- Attends meetings of the Al-Anon Information Service (AIS/ Intergroup).
- Acts as liaison between the group and the AIS.
- Reports AIS activities to the group.
- The Alternate GR may serve as the ISR, and the GR serve as the Alternate ISR\*.

**Greeters:**

- Make sure that all attendees are welcomed, particularly those new to the group.
- Give literature and meeting schedules to all newcomers.

**Hospitality:**

- Sets up refreshments if the group provides them.
- Makes sure meeting area is cleaned up after the meeting.

**Business or Steering Committee:**

- Deals with questions of policy and local public outreach.
- Deals with any internal problems that arise between the group’s regular business meetings.

## Sponsorship

“**Sponsorship** is a mutual and confidential sharing between two Al-Anon or Alateen members. A Sponsor is someone with whom a member can discuss personal problems or questions; someone who willingly shares the experience, strength, and hope of the Al-Anon/ Alateen program” (from *Sponsorship, What It’s All About* [P-31]).

### Al-Anon Personal Sponsors

After a period of time, Al-Anon members will want to choose a personal Sponsor with whom they can identify. Members can encourage newcomers to find a Sponsor by sharing that Sponsors provide guidance; however Sponsors do not direct or give advice. The new member may have discussed problems with the contact before coming to meetings. This contact may or may not be asked to continue as a Spon-

---

\* Al-Anon and Alateen members who are also members of A.A. may not serve as GR or Alternate GR. See “Digest of Al-Anon and Alateen Policies,” *Dual Membership in Al-Anon/Alateen and A.A.*

sor; however, neither a contact nor a newly-chosen Sponsor should be used as a substitute for a meeting. Additional information is published in the pamphlet *Sponsorship, What It's All About* (P-31), and in the bookmark *Sponsorship—Working Together to Recover* (M-78), as well as on the Al-Anon/Alateen Members' Web site in the "Individuals" tab.

## Service Sponsors

Service sponsorship is a special relationship where one member shares their service experience with another member. This type of sponsorship can be a one-time situation, such as an outgoing trusted servant supporting their replacement, or an ongoing relationship. Service sponsorship helps both the service Sponsor and the sponsee acquire new skills while being an example of personal growth through service. Al-Anon Family Groups worldwide benefits when members are enthusiastic about service. For more information about service sponsorship, read the pamphlet *Service Sponsorship—Working Smarter, Not Harder* (P-88).

## Alateen Group Sponsors

An Alateen Group Sponsor is an Al-Anon member who is currently certified by the Area process as an Al-Anon Member Involved in Alateen Service (AMIAS), meets all of the Area's Requirements for service as an Alateen Group Sponsor, and has made a commitment to be of service to an Alateen meeting on a regular basis. (See "Alateen Policy" in the "Digest of Al-Anon and Alateen Policies" section of the *Service Manual*.)

## Alateen Personal Sponsors

Just as Al-Anon members sponsor each other, Alateens sponsor each other. Alateen personal Sponsors are fellow Alateen members who can discuss personal problems or questions with those they sponsor. Personal Sponsors willingly share the experience, strength, and hope of the Alateen program. Al-Anon members do not sponsor individual Alateens.

# Supporting Group Growth

No matter what the size of the group, carrying the message is essential to attracting new members. It would be well to inform local professionals, including spiritual leaders, members of the medical and legal professions, and others in your community who have occasion to counsel families of alcoholics. This can be done either in

person or by mail. Be sure to let them know exactly when and where your meetings are held and whom their clients may call for a personal contact. Some groups announce meetings in a brief newspaper advertisement; some papers will include such listings without charge in the local events column.

Within the fellowship, inform your District Representative and local Al-Anon Information Service (AIS or Intergroup) to request the new meeting be listed in the local meeting schedule and Web site. Attending nearby Al-Anon groups and/or your district meeting will help spread the word. Additionally, A.A. groups are usually glad to cooperate with Al-Anon. They may be willing to announce the formation of a new group when they make their own announcements at open A.A. meetings.

## Public Outreach in the Community

### *Step Twelve*

*Having had a spiritual awakening as a result of these steps, we tried to carry this message to others, and to practice these principles in all our affairs.*

Informing the public about Al-Anon and Alateen is vital to the growth of the fellowship. Good public relations are important to our groups as well as the community at large. It is important that members understand the principle of anonymity and how it applies when doing public outreach service. We always protect our members' anonymity, but the Al-Anon/Alateen *program* is not anonymous. (See "Anonymity" and "Public Outreach" in the "Digest of Al-Anon and Alateen Policies" section of the *Service Manual*.)

Groups can have members meet with spiritual leaders, health-care providers, educators, or the manager of the local radio or television stations. Others may help bring the Al-Anon presence to a local hospital, rehabilitation center, or correctional facility. As long as members maintain personal anonymity when appearing in the media, as stated in Tradition Eleven, they can use their full names when contacting these professionals. Holding an open meeting to which community professionals are invited and placing Al-Anon and Alateen posters in public places are other ways to enhance Al-Anon's public relations.

Where there is a concentration of groups, groups can subscribe to an answering service to refer callers to the nearest group. As the groups grow, an Al-Anon Information Service (AIS or Intergroup) may be established. Many local newspapers have print and on-line listings of community resources, and the groups can make sure that

Al-Anon/Alateen information is included. A phone listing under “Al-Anon” (using a number that is not a personal phone number) will help people find our fellowship.

Many groups participate in public outreach activities coordinated by their district, Area, and/or local Al-Anon Information Service (AIS). Local media outreach (TV, radio, print media, posters/other printed materials, and the Internet) is handled by the district, Area, or AIS. Additional ideas for outreach projects are posted on the Members’ Web site, under “Public Outreach,” including service Guidelines and *The Best of Public Outreach*. (See also the “Public Outreach” section of the “Digest of Al-Anon and Alateen Policies” for information on outreach by individuals and groups.)

Keep your Area Public Outreach Coordinators informed of your outreach activities.

## Group Business

### Group Records

Keeping group information up-to-date is vital to assure that the most accurate meeting information is provided to persons seeking help in the Al-Anon and Alateen fellowship. Accurate records also keep communication flowing between the group and the WSO, and the group and local service arms. It is essential that groups promptly report changes in their meeting, location, meeting day, time, CMA (Current Mailing Address), Group Representative (GR), or phone contacts to their Area Group Records Coordinator or the WSO in writing. Group members can contact their District Representative (DR) to inquire about their Area process to submit group changes. The Area Group Records Coordinator can provide group reports to verify that the information on file is current.

### Group Business Meetings and Group Conscience

#### *Tradition Two*

***For our group purpose there is but one authority—a loving God as He may express Himself in our group conscience. Our leaders are but trusted servants—they do not govern.***

Group business meetings are held to share information and to include all group members in the activities and concerns of the group. Decisions a group makes are determined by an informed group conscience.

## **Group Business Meetings**

The group business meeting is an opportunity for members to share their ideas to increase group membership, express concerns, plan special meetings or projects, and other group business—such as changing the group name, CMA, group phone contacts, the meeting time and place, finances, meeting format, open or closed meeting status, etc. Business meetings are also an opportunity to identify and discuss solutions to group problems such as: gossip; dominance; the need for additional group service positions; rotation of leadership; inappropriate behavior of a member before, during, or after the meeting, etc.

Groups are within their autonomy to determine how to conduct their group business and how to reach a group conscience. Some groups schedule business meetings on a regular basis and others hold them as needed. Business meetings can be held before, after, or during the group meeting.

The manner in which a group business meeting is conducted and how to keep track of the group conscience decisions is as varied as the groups themselves. It is beneficial to the group and promotes unity when members are aware of the group's process for bringing their concerns or ideas to a business meeting. If the group does not have an established process for reaching a group conscience, this important step in the decision-making process would be decided prior to group discussion of a topic.

The group should also discuss who is eligible to vote on group matters; many groups request that only members who regularly attend the meeting vote at the group business meeting. Members who regularly attend more than one meeting may want to consider at which meeting to vote on district or Area matters, keeping in mind that our principles are spiritual, and voting on an issue more than once could be viewed as trying to control or influence the outcome.

Sufficient notice of the meeting and the agenda item(s) should be allowed for members to become informed about the matter. Announcing the business meeting and distributing pertinent information two or three weeks prior to the discussion and voting gives members of the group the opportunity to be informed, helps the group make better decisions, and promotes group unity.

A group's guideline for its business meeting could include: a sample agenda, advance notice needed to call a meeting, who chairs the meeting, length of time for discussion of each topic, what percentage will reflect unanimity and a majority, how the group conscience

decisions will be recorded, etc. Many groups use the Guideline *Taking a Group Inventory* (G-8a & 8b) and the *Al-Anon/Alateen Service Manual* (P-24/27) as resources when conducting a business meeting.

Some larger meetings have a Business or Steering Committee that meets separately to prepare an agenda for the business meeting.

### **Group Conscience**

The group conscience is the result of the group's business meeting discussions. The group conscience is the will of the group. The guiding principles for the group conscience are always the Twelve Traditions and the Twelve Concepts of Service. It may be helpful for the group to review these principles prior to any group discussions. Some simple group decisions may be decided quickly; however, others may take time. It is by taking the time necessary to hear from all members who want to participate that a group conscience evolves.

In order to make an informed group conscience decision, members need access to all the information about the issue they are being asked to discuss, they need clarity on what their discussions hope to accomplish, and they are asked to trust each other's motives and capabilities. By sharing information as equals, taking time for discussion, and maintaining principles above personalities during the discussions, groups are often able to reach unanimity in their decisions. If unanimity is not reached in the allotted timeframe of the meeting, discussions may continue at another time. Once a group conscience decision is made, the entire group supports the decision.

Concept Five tells us that members have the right of appeal. If a member disagrees with the outcome of a group conscience decision, they have the right to submit an appeal for reconsideration back to the body that made the decision. After an appeal is heard, regardless of whether the decision is maintained or altered, the individual accepts the group conscience.

### **Group Inventory**

Taking an inventory of the group helps to keep it healthy and invigorated. Groups are encouraged to make a periodic review using the Twelve Traditions and Twelve Concepts of Service as the guiding principles for the inventory. Members can use the inventory to discuss new service opportunities and address minor or major concerns before the group's unity is disrupted. The Guideline *Taking a Group Inventory* (G-8a & 8b) is a useful service tool that can aid in this process. (All Guidelines are available on the Al-Anon Members' Web site.)



## Group Problems and Solutions

The “Digest of Al-Anon and Alateen Policies” section of the *Al-Anon/Alateen Service Manual* (P-24/27) is a compilation of the World Service Conference’s group conscience on how to resolve many group questions or problems.

Al-Anon and Alateen members expect a safe and pleasant environment when they attend a meeting, and when one member causes unrest due to inappropriate or intimidating behavior, the entire group could be affected. Groups are within their autonomy to establish group behavioral guidelines in a manner that reflects their group conscience and abides by the Traditions.

When the behavior of any member impacts the group, members apply the Traditions to the problem, and determine how best to approach the individual(s) involved, to ask the member to change the behavior in question. This can be an exercise in applying Al-Anon principles so that the message is not a personal attack, but rather a request based on what is best for the Al-Anon group. Service tools on conflict resolution are available. See the *Al-Anon Conference Approved Literature Catalog* (S-15) or *CAL Order Form* (S-16).

Members may discuss specific religious tenets, forgetting that membership is open to all. One or two members may dominate the group, ignoring the principles of rotation in leadership. Members may violate our principles of anonymity and confidentiality by talking about what they hear in meetings. Every Al-Anon/Alateen member should feel bound to keep in strict confidence any personal matter heard at a meeting or from an individual. Each member should be able to feel confident that nothing said in the meeting will be repeated, by a Sponsor or other members.\*

The “Three Obstacles to Success in Al-Anon” are: discussion of religion, gossip, and dominance. Study of this passage from the pamphlet *Alcoholism, the Family Disease* (P-4) has helped many groups deal with these problems. (The passage is reprinted under “Optional Readings” in the “Suggested Meeting Format.”)

The books *Al-Anon’s Twelve Steps & Twelve Traditions* (B-8), *How Al-Anon Works for Families & Friends of Alcoholics* (B-22), and *Paths to Recovery: Al-Anon’s Steps, Traditions and Concepts* (B-24), give detailed suggestions on the application of the Twelve Traditions and Twelve Concepts of Service to solve group problems.

---

\*It is important to remember that Al-Anon/Alateen meetings are not above the law. Members need to exercise care in sharing information that could require outside reporting to local, state, provincial, and national authorities.

Lack of money may handicap the group, or its excess cause disagreements. See the pamphlet *Seventh Tradition* (S-21) and the *Reserve Fund Guideline* (G-41) for suggestions about handling and dispersing group funds. Both are posted on the Al-Anon/Alateen Members' Web site.

Taking a group inventory, a rededication of the group to its primary purpose, a study of the Traditions and Concepts of Service as they apply to the problem at hand, and seeking the experience, strength, and hope of other local groups, perhaps at district meetings, are all good methods of overcoming group difficulties. (See the *Taking a Group Inventory* Guideline [G-8a & 8b] that is posted on the Al-Anon/Alateen Members' Web site.)

Participation of members in group activities is important. This creates real involvement with the group and solidifies the relationship of the individual member to the group. Since each group has only a limited number of officers, it is best to have a policy of rotation, rather than have one member hold office for long periods of time. Other assignments may involve public outreach, bringing the refreshments for a limited period, setting up, and cleaning up. Reimbursement for refreshments from group funds is made by the Treasurer at each meeting. The more jobs available, the more members will participate and feel themselves to be an integral and important part of the group. Concept Four reminds us that "Participation is the key to harmony."

## Group Reports and Announcements

### ***Trusted Servants' Reports***

The Chairperson may call on the Secretary or another trusted servant to read announcements from other Al-Anon service arms, including those sent to the group's CMA (Current Mailing Address) from the WSO via postal mail and e-mail. The Treasurer may be asked to read the WSO Quarterly Appeal Letters and give the group a report on income and expenditures.

Periodically the Group Representative (GR) can update the group about district or Assembly meetings; however, at each meeting, the GR can share an item of interest from *The Forum*, *Group e-News*, or the *Al-Anon/Alateen Service Manual* (P-24/27). The GR can also keep the group informed about Al-Anon worldwide with interesting items from the *World Service Conference Summary* (P-46). A free copy of the *Conference Summary* can be ordered for the cost of postage or viewed on the Members' Web site. The Information Service Representative (ISR) can also report the activities of the local AIS or Intergroup back to the group.

## Other Group Announcements

### *Tradition Six*

*Our Family Groups ought never endorse, finance or lend our name to any outside enterprise, lest problems of money, property and prestige divert us from our primary spiritual aim. Although a separate entity, we should always co-operate with Alcoholics Anonymous.*

It is important that only Al-Anon/Alateen events are announced in our meetings. Because of our special relationship with A.A., A.A. events with Al-Anon and Alateen participation can be announced, but at an Al-Anon meeting or meeting location, groups do not announce or discuss activities of other Twelve Step programs. Publicizing events of other organizations creates an appearance of affiliation, even if the event is composed primarily of Al-Anon or Alateen members. (See the sections on “Religion/Philosophies” and “Dilution of the Al-Anon Program” in the “Digest of Al-Anon and Alateen Policies” section of the *Al-Anon/Alateen Service Manual* [P-24/27].)

Note that in order to use the name “Alateen,” any event with Alateen participation must have a connection to the Al-Anon Area in which it is held, and have event requirements that meet or exceed the Area’s Alateen Safety and Behavioral Requirements.

## Group Finances/Budget

### *Tradition Seven*

*Every group ought to be fully self-supporting, declining outside contributions.*

In keeping with Tradition Seven, a group’s membership is the source of its funds. Assistance from sources outside of Al-Anon or Alateen violates this Tradition. There are no dues or fees to attend Al-Anon or Alateen meetings. Supporting Al-Anon and Alateen groups financially is a way for members to express their gratitude for the help they have received from the program, thus ensuring that Al-Anon and Alateen will be available when someone seeks recovery from living with the effects of alcoholism.

Group funds are used to support Al-Anon’s purpose of carrying its message of help and hope to those who still suffer. Group contributions support all levels of Al-Anon service including the district, the local Al-Anon Information Service (AIS/Intergroup), the Area, and the World Service Office (WSO).

Most groups do not accumulate money beyond current needs and a small reserve, with just enough funds to pay the GR expenses to

Assembly and group expenses for a couple of months. This can be decided by making an informed group conscience decision.

Group expenses may include:

- Rent (may include insurance) for a meeting place.
- Group Representative’s expenses to attend and participate at district and Area Assembly meetings.
- Al-Anon Information Service (AIS/Intergroup) Representative’s (ISR) expenses to attend and participate at AIS meetings.
- Conference Approved Literature, including Al-Anon and Alateen books and pamphlets for sale to members. Most groups offer lower-priced pamphlets and leaflets to newcomers and members at no charge.
- Miscellaneous expenses agreed to by the group conscience such as babysitting, public outreach activities, refreshments, etc.

The group supports Al-Anon/Alateen financially at all levels of service by contributing to:

- Their district, Al-Anon Information Service (AIS/Intergroup), and World Service Area (state/province) structure that serves the group.
- The World Service Office, which serves all groups. (In keeping with Tradition Seven, support of the World Service Office is the responsibility of all Al-Anon members, groups, and service arms.)\*

Members work out a financial budget for the group. They plan how funds will be budgeted for the purchase of literature, refreshments, and contributions to the service arms. Some groups take additional collections for special local projects within the district or Area. If necessary, groups can add to the voluntary contributions by having fund-raising events. (See “Financial Matters” in the “Digest of Al-Anon and Alateen Policies” section of the *Al-Anon/Alateen Service Manual*.)

In keeping with Traditions Six and Seven, the group does not provide financial aid to members in need or to any outside enterprise. Individuals are free to help others in need as they choose; however it is always without involving Al-Anon’s name or other group members.

If a group is not able to support the service levels due to excessive meeting expenses, it may wish to reconsider its choice of meeting locations. A group should not give all of its funds to an outside entity, such as a clubhouse, even as a condition of using the meeting room.

---

\*In countries with a national office, groups support their General Service Office (GSO) and the WSO.

A group may need to periodically review its budget as changes to meeting expenses occur, such as a rent increase, a change in attendance, a drop in member donations, funding a group public outreach activity, etc. Al-Anon groups are not responsible to support a clubhouse, other than paying rent. Likewise, electronic on-line meetings pay rent to the Web site that hosts them, but are not otherwise responsible to support the Web site.

The Quarterly Appeal Letter from the WSO provides individual members the opportunity to participate in Twelfth Step work beyond the group level. The letter is sent to the CMA (Current Mailing Address) of the groups in the World Service Conference structure in February, May, August, and November (and also to groups worldwide in November). It is requested that the letter be read at two successive meetings, and followed by a special collection. This again is an opportunity for members to contribute in gratitude for what Al-Anon/Alateen has given them. Some groups choose to add an additional contribution to the collection. Some Areas, Al-Anon Information Services, and districts may also send an appeal letter to the groups.

### **Group Bank Accounts**

Al-Anon and Alateen groups are not required to have a bank account; however, some groups choose to have them. It is a decision of the group conscience. In order to make an informed group conscience decision, it is recommended that members be provided with all the information pertaining to the bank account, including fees and disclosure requirements. It's important to note that individual Al-Anon and Alateen groups are not considered to be nonprofit organizations and they are not branches or chapters of the World Service Office. The WSO cannot give its non-profit number to local groups because the WSO has no authority over local group funds. Al-Anon and Alateen groups are autonomous in their financial matters. (See "Incorporation and Taxes" in the "Digest of Al-Anon and Alateen Policies" section of the *Al-Anon/Alateen Service Manual* [P-24/27].)

Al-Anon and Alateen groups in the U.S. that choose to have a bank account are required to obtain a Federal Employer Identification Number (EIN) from the Internal Revenue Service for the bank to keep on file. The EIN does not give legal status to the group, it does not make them "tax-exempt," and it is not to be confused with the WSO ID number.

The trusted servant applying for the EIN and/or the bank account may be required to submit their personal information (full name, address, and social security number). A member who is comfortable with providing this information should handle this service. It is suggested that group bank accounts have at least two signatures on every check and that two to four members are authorized to access the account.

Canadian banks may require similar documentation from the Canadian Revenue Agency to obtain a community bank account.

It is not recommended that group funds be deposited into a member's personal account (or a new personal account using a member's social security number), as such accounts legally belong to the member, not the group, and accurate record-keeping could be difficult. If the member becomes incapacitated or ill, the group might not be able to access the account. In the event of the member's death, the account becomes part of the member's estate and the group could lose its funds.

Banking requirements may vary in other countries and groups must comply with local banking requirements and regulations.

Please contact the WSO for additional information.

### ***Insurance***

Many meeting places require liability insurance and "hold harmless" waivers from Al-Anon groups. The U.S. and Canadian laws do not allow for the WSO to provide blanket insurance coverage for groups and service arms. Groups requiring this coverage are encouraged to first contact their district or Area as there are some that can provide liability coverage for groups. Where this is not the case, several groups that meet at one place might be able to combine their resources and obtain one policy. Laws differ from place to place and it is suggested that groups contact someone in their locale regarding liability insurance. Paying for insurance should not jeopardize the group's ability to fulfill the spirit of the Traditions and support the Al-Anon and Alateen service arms. If a group is not able to take care of its immediate needs, it may need to reconsider its choice of meeting locations.

# Resources for Members and Groups

## Al-Anon Web Sites

Many Al-Anon Areas, districts, and Information Services have established Web sites for public outreach and member information. The WSO has two Web sites as resources to members and the public.

**The WSO Public Outreach Web Site** ([www.al-anon.alateen.org](http://www.al-anon.alateen.org))

Information for newcomers, professionals, and the media can be found on the WSO Public Outreach site. Features include: audio podcasts, the *Al-Anon Faces Alcoholism* magazine, press releases, samples of Conference Approved Literature and *The Forum*, Al-Anon Information Services contact information, links to Area and AIS Web sites, an on-line shopping cart, and more.

**WSO Members' Web Site** ([www.al-anon.alateen.org/members](http://www.al-anon.alateen.org/members))

This password-protected site includes the complete *Al-Anon/Alateen Service Manual* (P-24/27), Al-Anon/Alateen Guidelines, *World Service Conference Summaries*, *Area Highlights*, forms, outreach materials, WSO financial information, podcasts and blogs, *The Forum* calendar, items of interest from WSO Archives, and the latest news from WSO.

To access the Members' Web site:

- Type [www.al-anon.alateen.org/members](http://www.al-anon.alateen.org/members) in your browser (or click on the "Member?" tab on the Public Outreach site).
- Select your language (English, Spanish, or French).
- Your password is any version of your home group name, followed by the letters AFG. Example: Your home group is Tuesday Serenity AFG. Your password could be Tuesday AFG or serenityafg.

## Guidelines Relevant to Groups

The shared experiences of Al-Anon and Alateen members on various topics have been compiled and published by the World Service Office (WSO) and can be found on the Al-Anon/Alateen Members' Web site.

Guidelines that may be helpful to groups include:

- *Members Interested in Speaking* (G-1)
- *Beginners' Meeting* (G-2)
- *Cooperation Between Al-Anon and A.A.* (G-3)
- *Taking a Group Inventory* (G-8a & G-8b)

- *Outreach to the Public* (G-10)
- *Group Representatives* (G-11)
- *How to Start an Al-Anon Group* (G-12)
- *Suggested Programs for Meetings* (G-13)
- *Starting an Alateen Group* (G-19)
- *The Open Al-Anon Meeting* (G-27)
- *Outreach to Professionals* (G-29)
- *Ordering Literature* (G-31)
- *Alateen Safety Guidelines* (G-34)
- *Electronic Al-Anon Meeting Guideline* (G-39)
- *Guideline for Al-Anon Web Sites* (G-40)
- *Reserve Fund Guideline* (G-41) (contains information about group budgets, etc.)

## Newsletters/Timely Publications

- *Group e-News*: This electronic newsletter is e-mailed monthly to the group's CMA (Current Mailing Address). It contains timely news and announcements from the World Service Office (WSO).
- *The Forum*: Al-Anon/Alateen's monthly magazine contains recovery stories from members, as well as news and information from the World Service Office. *The Forum* provides meeting topics as well as a meeting anytime, anywhere. Sharing sheets are available on the Members' Web site.
- *Alateen Talk* is Alateen's quarterly newsletter, distributed to all registered Alateen groups and by subscription. Alateen members share their recovery and Alateen Group Sponsors share their experiences in Alateen service. Sharing sheets are mailed with every issue, and are posted on the Members' Web site.

## Literature and Service Materials

Al-Anon/Alateen literature and service materials help members to continue their recovery between meetings and gain insight into themselves and the principles of the Al-Anon/Alateen program. Conference Approved Literature (CAL) is written by and for our members, and goes through a thorough review process by numerous Al-Anon members to assure that it conveys the program in a consistent and comprehensive manner. Samples from CAL are posted on the WSO's Public Outreach and Members' Web sites.



Al-Anon/Alateen service tools help members to conduct the business of Al-Anon/Alateen in a healthy, productive way. Many service tools, including all of the Al-Anon/Alateen Guidelines, the *Service Manual*, and outreach materials are available on the WSO Members' Web site to download and print as needed. Other outreach materials are available at very low cost. A complete *Al-Anon/Alateen Conference Approved Literature and Service Materials* catalog (S-15) is mailed annually to every Al-Anon/Alateen group.

Most Al-Anon-produced materials, including *CAL*, *The Forum*, *Area Highlights*, and *Alateen Talk*, are appropriate to use and share at Al-Anon/Alateen meetings. Members are always free to read other publications, but only Al-Anon/Alateen materials are used in Al-Anon/Alateen meetings. This ensures that our program message stays consistent with our principles. (See "Conference Approved Literature and Service Tools/Materials" in the "Digest of Al-Anon and Alateen Policies" section of the *Service Manual*.)

## Structure of the Al-Anon/ Alateen Fellowship

The links of service may vary around the world. Each structure organizes the groups according to the needs of the structure.

In addition to the definitions of basic terms found in this section, more information about service positions is in the "World Service Handbook" section of the *Al-Anon/Alateen Service Manual* (P-24/27). Guidelines are additional resources and are posted on the Al-Anon/Alateen Members' Web site.

### Group Structure

The foundation of the Al-Anon Family Groups structure is the membership. The basic unit is the Al-Anon or Alateen group, which may consist of any two or more individuals coming together for mutual help.

The group's operations are the responsibility of a set of officers/leaders, who are elected by the members. Officers/leaders are usually changed every six months so that everyone has an opportunity to serve the group. These officers/leaders, depending on the size of the group, may be the Secretary and the Chairperson. In time, the group may need a Treasurer, Program Chairperson, and other group officers listed in this publication. The Group Representative (GR), an officer as well, is elected for a three-year term and represents the group's

concerns and wishes at the district and Area, as well as informing the group of what is happening in Al-Anon in the district, Area, and worldwide. GRs are entrusted with the “right of decision” to vote on behalf of the group according to their conscience and the good of Al-Anon as a whole. (See the “Concepts of Service” section of the *Service Manual* and the *Guideline Group Representative* [G-11].) GRs and other officers are leaders and trusted servants who perform their duties in keeping with the Traditions and Concepts of Service, yet they have no authority over the group. Their functions are described under the heading of “Suggested Duties of Group Officers/Leaders.”

There are two major lines of communication between the individual group and Al-Anon and Alateen as a whole. The first is the World Service Conference that directly serves Al-Anon and Alateen groups in the U.S. and Canada (including their territories, Bermuda, and Puerto Rico), and groups and structures in other countries (whose voice is heard through the International Coordination Committee). The second is the clearinghouse known as the World Service Office (WSO), headquarters of the Al-Anon Family Groups, which acts as the service center for groups throughout the world and is the link with other national General Service Offices (GSOs), several of which have their own Conferences.

## Districts

The district is the first link from the groups to the Area, the WSO, and the World Service Conference. Districts are comprised of a number of groups within a geographical part of a city, state, or province that meet as needed. The Group Representatives (GRs) from the groups in this geographical area attend the district meetings to represent their group. Decisions may be made on holding local functions, doing local outreach, and news will be disseminated to and from the groups.

Each district elects a District Representative (DR), who may visit the groups and represents their voice at Area World Service Committee meetings. Each district may have officers and coordinators to help the district carry the message. The district and its officers are a resource to their groups, and may be called upon to resolve questions or problems. For more information on districts and district meetings, see the “World Service Handbook” section.

## Al-Anon Information Service (AIS/Intergroups)

An Al-Anon Information Service, also known as an Intergroup, is a local service established and maintained by one or more districts or by groups located close enough to one another for easy access and com-

munication. Geographical boundaries need not be observed unless one Information Service conflicts with another nearby, in which case a geographical division should be set by mutual agreement.

An Al-Anon Information Service usually performs the following functions:

- Maintains a listing in the local phone directory so that those seeking information about Al-Anon and Alateen can easily find it.
- Maintains a post office box or an office address for listing with the World Service Office.
- Receives postal mail, e-mail, and phone inquiries, and forwards them to the appropriate group for response or follow-up.
- In cooperation with Area Group Records Coordinator, updates, publishes, and distributes lists of group meetings in their local area.
- Plans and conducts program-exchange meetings where the groups' Chairpersons or Program Chairpersons exchange teams of speakers for a scheduled period.
- Serves as an avenue for local public outreach service, which is channeled through the districts whenever possible.
- May maintain a stock of Conference Approved Literature (CAL), and may register with the WSO as a Literature Distribution Center (LDC) to sell CAL.\*
- May maintain a Web site that is linked to their Area Web site.
- Holds periodic meetings attended by all the Information Service Representatives where activity reports, including a financial update, are made and matters regarding the groups are discussed.
- Prints and distributes its own newsletter of local Al-Anon/Alateen activities for the groups that support it.

AIS phone numbers and mailing addresses are published in local directories, meeting lists, and on Web sites. In keeping with Tradition Eleven, AISs do not use personal numbers or addresses of any Al-Anon member. In this way, potential members may be referred without revealing the name, address, or phone number of any Al-Anon or Alateen member and personal anonymity is maintained.

Any local Al-Anon or Alateen group may agree to support an Information Service, but joining is purely voluntary. The Information Service is supported by the groups it serves within its geographical

---

\*The WSO will also register LDCs that operate separately from the local Information Service.

boundaries; it should not seek or accept support outside that area. Contributions are voluntary and are not a condition of membership.

The Guidelines *Al-Anon Information Services* (G-4), *Literature Distribution Centers* (G-18) and *Guideline for Al-Anon Web Sites* (G-40) are posted on the Al-Anon/Alateen Members' Web site.

### **Al-Anon Information Service Representation**

Experience has shown that the Information Service can be a function of districts, providing a network of communication. It is suggested that the Alternate Group Representative\*\* serve as the Information Service Representative (ISR) and the GR\*\* serve as the Alternate Information Service Representative. In addition, the Alternate District Representative may be a member of the AIS board, and the DR generally serves as the Alternate Information Service Board member. AISs send a representative, called an Al-Anon Information Service Liaison (AISL), to Area World Service Committee and Assembly meetings.

### **Areas**

Areas are comprised of groups and districts in a specific geographical space, usually an entire state or province. Every group in the Area has a voice and a vote in Area business through their Group Representative (GR). Each Area in the U.S. and Canada is represented at the annual World Service Conference by an Area Delegate, elected every three years by the GRs. Other Area officers include an Alternate Delegate, Chairperson, Secretary, and Treasurer. Area Coordinators serve as a link between the WSO departments and local trusted servants. Area Coordinators may include: Alateen, Archives, Public Outreach, Literature, Area Newsletter, Area Alateen Process Person, *Forum*, Web, and Group Records. All Area officers and coordinators are important links in the chain of service, and a resource to the groups and districts in their Area.

### **Area Assembly**

The Area Assembly is the business meeting where the groups send their representatives to express a voice and vote on behalf of the group. During an Assembly, the Delegate reports the activities of the World Service Conference. An Assembly can meet at least one or two times a year, or a minimum of once every three years. Many meet more often.

\*\* See the policy regarding "Dual Membership in Al-Anon/Alateen and A.A." in the "Digest of Al-Anon and Alateen Policies" section of the Al-Anon/Alateen Service Manual (P-24/27)

## Area World Service Committee

In between Assemblies, Area World Service Committee (AWSC) meetings are held, attended by the Assembly officers, all District Representatives and Al-Anon Information Service Liaisons, and the Area Coordinators of special services. At these meetings, the Assembly agenda is planned, information and reports are conveyed, and decisions may be made that cannot wait until the next Assembly.

## World Service Conference (WSC)

See also “World Service Handbook” section in the *Al-Anon/Alateen Service Manual* [P-24/27].

The World Service Conference (WSC) is an annual meeting of the elected Delegates from each of the Areas of the World Service Conference structure, the Board of Trustees, the Executive Committee, and World Service Office Conference staff.\* Through the discussions and deliberations at the WSC, the active voice and effective group conscience of Al-Anon is heard on world service matters.

Delegate members attending the WSC are chosen at Area Assemblies by the groups through a series of elections. Having been elected in this democratic manner, they are entrusted by the group conscience, in accordance with Concept Three, to make decisions for the fellowship worldwide.

### From the Group to the WSC

Each Al-Anon and Alateen group elects a *Group Representative (GR)* and in this way connects to Al-Anon worldwide as described in Concept One. The GR attends district meetings, where problems are discussed and information is exchanged. A district is one segment of an Assembly Area in a state or a province. GRs elect a *District Representative (DR)* to represent the district at the Area World Service Committee (AWSC) meetings.

DRs and GRs are expected to attend meetings of the Assembly whenever its Chairperson calls them. Once every three years, at the Assembly, the eligible GRs elect a *Delegate* to the WSC for the ensuing three years.

This succession of elected links gives each Al-Anon and Alateen group a voice in the WSC. The same links provide a continuous chain of communication for the flow of information between the groups, districts, Assemblies, World Service Conference (WSC), and the

\* See the policy regarding “Dual Membership in Al-Anon/Alateen and A.A.” in the “Digest of Al-Anon and Alateen Policies” section of the *Al-Anon/Alateen Service Manual* (P-24/27)

World Service Office. When Conference decisions are made, the same communication chain carries the information back from the Delegate, to the Assembly, to the AWSC, to the District Representative, to the Group Representative, and to the group members. A group that fails to have a Group Representative denies its members a voice and causes a break in the link of communications. A comprehensive summary of each annual WSC, usually held in April, is available to all members on the Al-Anon Members' Web site. A free printed copy can be ordered for the cost of postage.

As Al-Anon developed in countries outside the World Service Conference structure, members organized service structures to serve their groups. Representatives from national General Service structures are invited to attend the WSC with voice but no vote, since those representatives vote at their own National Service Conferences.

## World Service Office (WSO)

*In other countries, service is often provided by a national General Service Office (GSO) which is linked to the WSO through the International Coordination Committee. Each structure organizes the groups according to the needs of the structure.*

(See also the "World Service Handbook" in the *Al-Anon/Alateen Service Manual* [P-24/27])

As the principal service center of the fellowship, the WSO acts in conformity with the wishes of the Conference. It publishes all *Conference Approved Literature (CAL)*. Many functions and activities of the fellowship circulate through this office. It is the center, not the head; it serves but does not control or direct. The relationship of the WSO to the groups is fully explained in "Al-Anon's Twelve Concepts of Service."

Work at the WSO is done by a paid staff, some of whom are Al-Anon members. They take care of the huge volume of creative and clerical work involved in implementing the decisions of the WSC, as well as routine matters.

New groups are given help in their early attempts to become established. Correspondence is maintained with the thousands of groups in the fellowship. Lone members all over the world are encouraged to form new groups.

The *Board of Trustees*, which meets quarterly, is the legal entity responsible for administration of Al-Anon's funds and services. Its service arm, the *Executive Committee*, which meets monthly, is delegated by the Board to make administrative decisions required in the interim between Board meetings.

## WSO Committees

WSO committees are vital to Al-Anon Family Groups. Since Al-Anon's earliest days, they have provided input, feedback, and creative ideas to assist the Board of Trustees in its efforts to lead Al-Anon Family Group Headquarters, Inc. WSO committees use the Knowledge-Based Decision-Making Process to Reach an Informed Group Conscience (KBDM).<sup>\*</sup> These committees always fit into the overall context—never acting as a separate entity, always sharing the work of the Board, but aware of the limits of their decisions.

Some of the work handled by the WSO's traditional committees has been moved to "work groups," "thought forces," or "task forces," which report back to their originating bodies. Here are the current definitions:

- A *WSO committee* is formed by the Board of Trustees and responds to an ongoing need of Al-Anon Family Groups. While it does not manage or conduct the active affairs of the service department it is related to (such as Public Outreach, Literature, etc.), it may make recommendations about any work the department is doing or considering. It is often thought to be a permanent part of an organization. It can be an originating body and a thought force or task force may evolve from a committee.
- A *work group* is a unit of people established to meet an ongoing need of the originating body. It can be considered a permanent part of the organization which has formed it. It can be an originating body. A thought force or task force may evolve from a work group. The objective is to complete its activity and present it to the originating body to move forward.
- A *thought force* is a temporary unit of people established to brainstorm ideas and to develop strategies on a single defined task or activity. They use the resources available such as members of the thought force and knowledge from the staff. For example, a problem identified could be a lack of clarity regarding roles. Strategies that are suggested might include writing job descriptions (the idea, not the actual job description); components of a guideline; or adding text to a portion of the *Service Manual* to clarify. The objective is to identify the potential idea not to write the actual text itself. The thought force is not expected to have all the answers or to provide the final solutions. A thought force

<sup>\*</sup>For a detailed explanation of KBDM, see the 2008 World Service Conference Summary, available on the Members' Web site.

may lay the foundation for the work of a task force. Sometimes they offer recommendations resulting from their findings. A thought force presents its information to the originating body to move forward. They are “thinkers,” not “doers.”

- A *task force* is a temporary unit of people established to work on a single defined task or activity. They use the resources available such as members of the task force and knowledge from the staff. For example, a task could be to implement one of the suggested strategies from the thought force. If writing job descriptions is chosen, then the task force writes the job descriptions. The objective is to complete the job description and present it to the originating body to move forward. A task force may fulfill the recommendations made by a thought force. Task forces are the “doers.”

None of these groups is a decision-making body, but they may make recommendations. Each body’s objective is to complete its activity and present it to the originating body, to move forward.

Reaching consensus on WSO committees, work groups, task forces, and thought forces is done in the same manner as it is done at the group level. Members need access to all the information about the issue, they need clarity in what their discussions hope to accomplish, and they trust each other’s motives and capabilities. Committee decisions take time, but it is in that time necessary to hear from all members who want to participate that a group conscience evolves. Each member puts forth his or her ideas, willing to sacrifice them, believing that the best outcome will come from the discussion.

Some committees meet regularly while others meet on an as-needed basis, all with the underlying goal to spread the message of Al-Anon to all those who need it. Individual committees seek consensus in order to make recommendations to the Board of Trustees. The Executive Committee oversees day-to-day operations of the WSO including services to members, groups, and electronic meetings. The Finance and Policy Committees have agendas specific to these matters, while Literature and Public Outreach make recommendations pertinent to current issues in these areas. Finding new ways to serve the Alateen membership is the job of the Alateen Advisory Committee. Maintaining adherence to the principles of the program in *The Forum* is the role of the *Forum* Editorial Advisory Committee. The International Coordination Committee (ICC) handles all issues related to groups and General Service Offices (GSOs) outside the World Service Conference (WSC) structure. The ICC provides the connection between the GSOs and the WSC structure.



# Basic Terms Used in AI-Anon Service

*See the “World Service Handbook” section of the AI-Anon/Alateen Service Manual (P-24/27) for a fuller explanation. In countries outside of the World Service Conference structure, service terms and structures vary according to their needs.*

The individual member usually thinks of AI-Anon/Alateen as the group to which he or she belongs. Yet that single group is one of thousands that meet in all parts of the world, all trying to cope with the same problems that face us.

An understanding of the whole AI-Anon picture will show the important role played by each individual in the overall work of the AI-Anon/Alateen fellowship.

## Groups

The **group** is the basic unit, where close personal interchanges among members take place, where AI-Anon ideas are discussed and applied to specific personal problems. The entire AI-Anon/Alateen fellowship structure exists for the sole purpose of helping the group members. The important qualification for every member is participation. To ensure our own growth, we should welcome opportunities to be useful to the group: to accept group offices, to support those members who do the work of the group, and to stand ready at all times to comfort and help other members meet their critical problems.

**Group Representative (GR):** an AI-Anon/Alateen member who represents the group at district and Area Assembly meetings, where they share information of importance. The GR brings that information back to the group.

**CMA:** The Current Mailing Address receives the group mail from the WSO and takes it to the group. (See “CMA” under “How to Start a Group.”)

**Group Contacts:** AI-Anon members who are willing to receive calls from newcomers seeking AI-Anon’s help or others seeking directions or information about the AI-Anon meeting.

**AI-Anon personal Sponsor:** someone with whom a member can confidentially discuss personal problems or questions and someone who willingly shares the experience, strength, and hope of the AI-Anon program.

**Service Sponsor:** guides a member in applying the Traditions and Concepts of Service, and shares experience, strength, and hope while giving service to Al-Anon.

**Al-Anon Member Involved in Alateen Service (AMIAS):** an Al-Anon member who is currently certified through their Area Alateen process and is therefore eligible to be directly responsible for Alateens while being of service to Alateen, including service as an instant or temporary Alateen Group Sponsor.

**Alateen Group Sponsor:** an Al-Anon member who is currently certified by their Area process as an Al-Anon Member Involved in Alateen Service and has made a commitment to be of service to an Alateen meeting on a regular basis.

**Alateen personal Sponsor:** a fellow Alateen member who can discuss personal problems or questions with those they sponsor. Personal Sponsors willingly share the experience, strength, and hope of the Alateen program.

## Districts

The **district** is a geographical segment containing a number of groups, located relatively close to one another. Group Representatives attend district meetings to discuss business matters, and share their group experiences with each other.

**District Representative (DR):** is elected by the GRs from within their district. The DR chairs the district meetings, represents the groups in their district at Area World Service Committee meetings, and serves as a resource and information source for the groups.

## Al-Anon Information Services/Intergroups

An **Al-Anon Information Service (AIS)**, sometimes called an Intergroup) is a local service established by the groups and/or districts within its geographical boundaries. It exists to aid the groups it serves in the common purpose of carrying the Al-Anon message to the families and friends of alcoholics. An AIS Liaison member links the AIS to the Area.

**Al-Anon Information Service Liaison (AISL)** members are appointed or elected by the Information Service/Intergroup to serve as the communication link between the Information Service and the Area Assembly/Area World Service Committee.

## Literature Distribution Centers

A **Literature Distribution Center (LDC)** provides Al-Anon members with local access and quick delivery of Al-Anon Conference Approved Literature, including books, pamphlets, booklets, kits, posters, and films, and other Al-Anon material.

## Areas

The **Area** is made up of all the districts in a state or a province (some large states/provinces are divided into more than one Area). Each Area is represented by one Delegate at the annual World Service Conference.

**World Service Delegate:** an Al-Anon/Alateen member elected at the Area Assembly to represent all the groups in his or her Area at the annual World Service Conference. The Delegate is the primary communication link between the groups and the World Service Office (WSO).

**Assembly:** the Area Assembly, composed of all the GRs in the Area, convenes at least every three years to elect a Delegate and other Assembly officers. Other Area business is conducted at regular Assembly meetings called by the Area Chairperson.

**Area World Service Committee (AWSC):** consists of the officers of the Assembly, District Representatives, Coordinators, and AIS Liaison members. They meet between Assemblies to plan the Assembly agenda and deal with other Area business, as needed.

**Area Coordinators:** coordinate the activities of their service (i.e., Alateen, Archives, Conventions, *Forum*, Group Records, Literature, Public Outreach, and Web site) in the Area and are a liaison between the Area World Service Committee (AWSC), other Area committees, and the groups. They convey service information from the WSO to the districts, AISs, and groups. In order to perform their duties as a Coordinator, Area Alateen Coordinators must be certified as an Al-Anon Member Involved in Alateen Service (AMIAS) in the Area they serve.

**Area Alateen Process Person (AAPP):** serves as the Area's designated Alateen contact with the WSO Group Records Department regarding Alateen forms. The AAPP collaborates with the Alateen Coordinator and the Group Records Coordinator, as determined by the Area process, concerning the distribution and submission of Alateen forms and WSO Group Records reports.

**Area Newsletter Editor:** performs a vital service by providing up-to-date information to the groups within the Area as guided by the AWSC.

## World Service

**Conference Approved Literature (CAL):** the CAL process ensures that ideas for literature be authorized by the Conference and that designated Al-Anon members, Delegates, WSO staff, and volunteers review the material before publication and/or production.

**Electronic Meetings:** offer hope and comfort to relatives and friends of alcoholics through various electronic means.

**Inmate Correspondence Service:** a service that links incarcerated Al-Anon members with members who attend Al-Anon meetings regularly through letters that serve as a meeting.

**Inmate Contact:** an active member of Al-Anon who attends meetings regularly and is willing to share their Al-Anon program with an incarcerated member through written correspondence.

**Lone Member:** an Al-Anon member who cannot attend Al-Anon meetings due to distance or disability. Lone members are encouraged to start Al-Anon meetings in their locale when feasible.

**Lone Member Contact:** an active Al-Anon member who attends meetings regularly and is willing to share our Al-Anon Twelve Step recovery program through written correspondence with Lone Members.

**TEAM (Together Empowering Al-Anon Members):** a TEAM event is a partnership between an Area(s) and the World Service Office (WSO) with the aim of providing an opportunity for Al-Anon and Alateen members to learn more about service and the Al-Anon program. This is accomplished by the Area and a WSO Task Force working together to plan an agenda of workshops and presentations that address the Area's specific needs and expand members' understanding of our worldwide fellowship. TEAM events are sponsored by the Area(s) and the WSO.

## International

**General Service Office (GSO):** the term given to a national service structure in a country outside of the World Service Conference structure. GSOs are linked to the World Service Office through the International Coordination Committee.

**International Al-Anon General Services Meeting (IAGSM):** a biennial service meeting for General Service Offices/national service

structures. The purpose of the IAGSM is to share the experience of Al-Anon national services around the world through its Delegates. It is not a decision-making body and passes any recommendations through the International Coordination Committee to the Board of Trustees. In addition to the International Coordination Committee members attending this meeting, the WSO Board of Trustees sends two Trustees, one from the United States and the other from Canada.

**National service committee:** a committee comprised of Al-Anon members that is authorized by the groups in a country outside of the World Service Conference structure to form a national service structure. This committee usually evolves from an Al-Anon Information Service or Intergroup and ends when a permanent national service structure or General Service Office begins.

All requests to translate and print or to reprint Al-Anon/Alateen Conference Approved Literature must be submitted to the World Service Office for approval by the Board of Trustees prior to any printing and distribution of Al-Anon materials. See “Conference Approved Literature and Service Tools/Materials” in the “Digest of Al-Anon and Alateen Policies” section of the *Service Manual* for more information.

## **Notes and Updates**

## **Notes and Updates**

## **Notes and Updates**



## **Notes and Updates**

# Digest of Al-Anon and Alateen Policies

*The “Digest of Al-Anon and Alateen Policies” reflects policy statements that grew out of questions and experiences from the Al-Anon fellowship worldwide. They are interpretations of our basic guides, the Twelve Traditions and the Twelve Concepts of Service.*

## Table of Contents

Introduction	79
Channel for Arriving at Policies	79
World Service Conference (WSC)	80
World Service Office	80
Membership and Group Meetings/Conventions	81
Membership and Groups	81
Meetings	83
Conventions	85
Alateen Policy	87
Area Alateen Safety and Behavioral Requirements	87
Area Alateen Process	88
Starting an Alateen Group	88
Alateen Group Sponsors	88
Alateen Personal Sponsors	89
Who Attends Alateen Meetings	89
Alateen Membership/Age Range	89
Funding/Seventh Tradition	90
Alateen in Schools and Other Facilities	90
Events with Alateen Participation	90
Anonymity	91
Anonymity Outside Al-Anon/Alateen	91
Anonymity Within Al-Anon/Alateen	92
Anonymity in Our Personal Growth	94
Financial Matters	95
Contributions to WSO	95
By Individual Members	95
By Groups and Other Service Entities	96
Reserve Fund	96
Discounts and Services	97
Fund Raising	97
Selling Products and Chances	98
Payment for Speaking	98
Public Meetings	99
Use of Group Funds	99

*Note: Vertical lines in outer margins indicate where changes were made for this edition.*

<b>Local Services</b>	<b>100</b>
Naming a Service	100
Answering Services	100
Information Services (Intergroups)	100
Employees in Al-Anon Services	101
Autonomy of Groups	101
<b>Conference Approved Literature and Service Tools/Materials</b>	<b>102</b>
Conference Approval	102
WSO Service Tools	103
<i>Al-Anon/Alateen Service Manual</i>	103
Authorization for Production	103
Identification of Al-Anon/Alateen Publications	103
Use of Material at Al-Anon Meetings	104
<i>The Forum</i>	104
Other WSO Publications	105
Copyrights	106
Symbols/Logos	106
Authorization to Publish and Reprint	107
Translations	108
Literature Sales outside the United States and Canada	108
<b>Public Outreach</b>	<b>109</b>
The 1966 WSC Statement on Public Relations	109
The Philosophy and Spiritual Principles of Al-Anon's Public Outreach	110
Members and Groups Carry the Message	110
Outreach is Based on Attraction Rather than Promotion	113
Personal Anonymity is Maintained at the Level of Press, Radio, Films, TV, and the Internet	114
Cooperation and Goodwill Strengthen Public Outreach	115
Members Continually Broaden the Way They Carry the Message by Using New and Innovative Forms of Communication	115
<b>Incorporation/Taxes</b>	<b>117</b>
Al-Anon Family Group Headquarters, Inc.	117
National General Services	117
Assemblies (United States)	118
Al-Anon Information Services (Intergroups), Literature Distribution Centers (USA)	119
<b>Al-Anon As It Relates to Others</b>	<b>120</b>
Alcoholics Anonymous—Cooperation	120
Outside Agencies	121
Commercial Enterprises	122
Religion/Philosophies	123
Dilution of the Al-Anon Program	124

# Introduction

These policy statements grew out of questions and experiences from the Al-Anon fellowship worldwide. They are interpretations of our basic guides, the Twelve Traditions and the Twelve Concepts of Service.

The questions and shared experiences came from many sources—Al-Anon and Alateen members, regional and national conferences, Delegates to the World Service Conference—and from all over the United States, Canada, and many other countries.

When an individual or a group seeks clarification of any matter relating to the Al-Anon fellowship, it is the responsibility of the World Service Office (WSO) Policy Committee to make statements that interpret and encourage use of the Traditions and Concepts. After approval by the Board of Trustees and the World Service Conference, these statements are set forth in the Policy Digest. To arrive at answers that are consistent, loving, and helpful takes time and patience, both on the part of the individual or unit seeking the clarification and on the part of the WSO Policy Committee.

As our fellowship grows and many more ideas and questions are raised, let us strive to live with and by what we have here, secure in the knowledge that changes and additions will be made as circumstances and our growth require.

## Channel for Arriving at Policies

The WSO Policy Committee is composed of a Chairperson, all members of the Board of Trustees, at-large members of the Executive Committee, the Chairpersons of all WSO Committees, and the Conference members of the WSO administrative staff.

The WSO Policy Committee is often asked to help when there is confusion about how a specific Tradition applies to a new or controversial situation in Al-Anon or Alateen. The Committee meets regularly during the year to review and discuss each problem or issue in light of the Traditions and determines an appropriate policy recommendation. The proposed policies are then brought to the Board of Trustees for consideration.

The Chairperson of the Policy Committee reports the interim policies passed by the Board of Trustees to the World Service Con-

ference (WSC) each year for its review. If the wording or intent of these policies is to be changed, it is done at the Conference. Action on each policy requires a majority of no less than a two-thirds vote for approval or disapproval by the entire Conference. The same procedure is required for major revisions and amendments to existing policies.

Policies approved by the World Service Conference are reported in many WSO publications, including *The Forum* and the *World Service Conference Summary*. Appropriate adjustments are made in updating this *Service Manual* and other Conference Approved Literature.

## The World Service Conference (WSC)

*See also "World Service Handbook"*

The WSC is the permanent body for the expression of the conscience of the Al-Anon/Alateen fellowship in the light of our Traditions. It usually meets annually during April. Its membership is composed of the elected World Service Delegates from each Assembly Area in the United States and Canada, the Trustees of Al-Anon Family Group Headquarters, Inc., the Chairpersons and WSO staff of all selected committees, and the members of the Executive Committee. Representatives from countries other than the United States and Canada may participate but not vote.

To keep the conscience of the fellowship alive, Delegates serve on the WSO's selected committees or subcommittees. For the sake of continuity and unity, each selected committee has its Chairperson plus "in-town" members who meet regularly throughout the year at the World Service Office.

## The World Service Office

*See also "World Service Handbook"*

The WSO is composed of executives, staff members, and selected committees supervised by the legally empowered Board of Trustees and its Executive Committee. It functions as a clearinghouse, providing service to the fellowship and spreading Al-Anon's message worldwide.

# Membership and Group Meetings/Conventions

## Membership and Groups

### *Membership Eligibility*

Anyone who feels his personal life is or has been deeply affected by close contact with a problem drinker is eligible for membership in Al-Anon/Alateen. (See “Families with Related Problems.”)

As the name implies, Alateen is designed for members in their teens. Alateens are members of the Al-Anon fellowship. Where there is no Alateen meeting available, young people are encouraged to attend Al-Anon meetings. (See “Alateen Policy” section.)

### *Who Can Start a Group*

The actual founding of the group and its functions is the responsibility of those qualified for membership. Occasionally a minister, doctor, social worker, or A.A. member initiates the formation of an Al-Anon/Alateen group. However, after the group has started, professional or A.A. participation should be limited to open meetings.

### *Registration of Groups*

The WSO will register any group designating itself as an Al-Anon Family Group with the understanding that it will abide by the Traditions and that meetings will be open to any Al-Anon member. (See “Alateen Policy” section for information on registering an Alateen group.)

The WSO cannot register any group that is solely for Al-Anon members who are also recovering alcoholics and members of A.A., because it does not qualify to have a Group Representative (GR).

There are Al-Anon or Alateen groups where meeting access is limited due to the facility’s entry restrictions. These groups meet at sites such as military bases, industrial plants, or schools.

### *Choosing a Group’s Name*

Having an appropriate group name is very important because it is included in local and on-line meeting directories and may be a potential member’s first impression of Al-Anon. The group’s name should be inviting to all and reflect Al-Anon principles. A group’s name should not imply affiliation with any other Twelve Step group, self-help group, commercial venture, agency, religious group, rehabilitation facility, or

other outside enterprise even if the name is associated with its location—e.g., the \_\_\_\_ Church AFG or the \_\_\_\_ Hospital AFG.

To help avoid confusion with other entities it is suggested that groups spell out their full name and include the letters AFG for Al-Anon Family Group.

The WSO will review proposed group names for adherence to Al-Anon principles. (See “Naming the Group” in “Groups at Work.”)

### **Assembly Representation**

Each Al-Anon/Alateen group elects a Group Representative (GR). (See “World Service Handbook.”) Assembly Areas should encourage the attendance of Alateen GRs at district and Assembly meetings.

### **Multiple Group Membership and Office-Holding**

Al-Anon members who attend several groups *regularly* and *participate fully* in all of them may consider themselves members of all those groups. Most members, however, consider one group their home group.

Membership entitles a person to vote and hold office. Whether members may hold office in more than one group is a matter of group autonomy, although it does deprive other members of the privilege of serving and growing. No member may, however, be Group Representative (GR) of more than one group at the same time.

### **Service Participation by Members of Al-Anon Family Groups Who Are also Members of Alcoholics Anonymous**

Al-Anon Family Groups and Alcoholics Anonymous (A.A.) share a common spiritual legacy in A.A.’s Twelve Steps and Twelve Traditions. Before Al-Anon was founded, family groups met with and beside A.A. groups. In 1951, various family groups banded together and agreed to organize Al-Anon Family Groups, a program dedicated to helping the friends and families of alcoholics. Over the years, Al-Anon developed its own service structure, based on the model provided by A.A.’s experience and guided by the Twelve Traditions.

Tradition Five defines Al-Anon’s single purpose. Tradition Six encourages cooperation with Alcoholics Anonymous, maintaining that Al-Anon is a separate entity that ought never affiliate or create the appearance of affiliation with any outside enterprise. Putting these principles into practice maintains a separation between the service structures of Al-Anon and A.A. This separation helps avoid

*continued on page 126*

## **Group Problems**

Any group or service arm within a Conference Area that fails to resolve its disputes or misunderstandings by application of the Traditions and Concepts of Service should seek guidance from its district or Area Assembly. If further guidance is needed, the matter can then be referred to the WSO or the respective national General Service Office (GSO). The WSO or GSO can only offer suggestions by relating the shared experiences of other groups or by providing the appropriate references in existing service material.

## **Meetings**

### ***Locating Meetings***

Al-Anon and Alateen meeting information can be obtained by contacting Al-Anon Information Services listed in local telephone directories and on the WSO Web Site, [www.al-anon.alateen.org](http://www.al-anon.alateen.org). The WSO toll-free meeting line number, 1-888-4 AL-ANON (888-425-2666), is available between 8 a.m. and 6 p.m., Eastern Time.

A printed list of Al-Anon Information Services and offices worldwide is found in *Getting in Touch with Al-Anon/Alateen* (S-23). Many Areas and Information Services post meeting information on their local Web sites, which are listed on the WSO site. (See “*Getting in Touch with Al-Anon/Alateen*,” and “World Directories of Al-Anon Family Groups.”)

### ***Open/Closed Meetings***

Closed meetings are for all Al-Anon members, anyone whose personal life is or has been deeply affected by close contact with a problem drinker. Open meetings may be attended by anyone interested in Al-Anon/Alateen.

### ***Introductory Meetings***

Introductory meetings can be held at institutions, such as hospitals, treatment centers, and shelters, or any other location where families and friends of alcoholics gather. Attendance changes frequently. Such a meeting is not considered an Al-Anon group and does not have its own Group Representative. Experienced Al-Anon members share the responsibilities for conducting introductory meetings and for inviting those in attendance to try a regular Al-Anon/Alateen meeting. Al-Anon groups, directly or through



their district, are encouraged to help with the cost of literature and other expenses for introductory meetings. Members must comply with the security requirements of the meeting location.

### **Electronic Meetings**

The Internet and other electronic telecommunication media are tools for carrying and sharing the Al-Anon program of hope and recovery around the world. These electronic meetings occur globally as well as locally without geographic restrictions. Consequently, electronic meetings do not have a Group Representative and are not part of any structure. They do, however, have a meeting contact.

When electronic meetings form, they register with the World Service Office (WSO) in order to use the Al-Anon name. Upon registration, they receive support from and have their voices heard and represented through the WSO. Registered meetings may request a license from the WSO to use in text format the Steps, Traditions, Concepts of Service, Suggested Welcome, Suggested Closing, and excerpts from Conference Approved Literature (CAL).

### **Audio Tape Recordings\***

Occasionally, Al-Anon/Alateen meetings are audio taped by members, but as a matter of courtesy, the person doing the taping should receive permission. Al-Anon/Alateen meetings may be taped with the following suggestions:

- Every member is aware and approves of the taping
- Anonymity is carefully preserved

### **Videotaping/Filming**

In keeping with Tradition Eleven, videotaping/filming at meetings is not recommended.

### **Films**

The use of films at closed meetings is not appropriate; experience shows such use lessens the opportunity and desire for personal exchange between members. This sharing is basic to our program of recovery.

Although it is not suggested as an alternative to having members speak, the occasional use of films at open meetings may be helpful. It is not, however, the most effective way to carry the Al-Anon

---

\* WSO has no responsibility in the matter of tape enthusiasts who realize a profit from the sale of taped talks of Al-Anon members.

message. The explanation under “Speakers from the Helping Professions” applies equally to the use of films.

Members sometimes plan special meetings to show the five films approved by the World Service Conference: *Lois’ Story*; *Al-Anon Speaks for Itself\**; *Alateen Tells It Like It Is\**; *Walk This Path of Hope\**; and *Lois W. and the Pioneers*. These special meetings are held in addition to a group’s regular meeting.

## Conventions

### ***Al-Anon/Alateen Area-wide Conventions, Rallies, Reunions, Roundups (or Any Other Large Get-Together)***

Conventions attract many members, drawing them to celebrate and share their experiences. Where possible, members planning Area or region-wide conventions work closely with the local Area World Service Committee(s). Good communication assures better attendance as well as goodwill. In many Areas, the Convention Chairperson is appointed or elected at the Area Assembly. The Chairperson or another convention committee liaison member has a voice and may have a vote on the Area World Service Committee.

### ***Distribution of Proceeds***

Surplus funds derived from conventions are usually contributed to the Area treasury and WSO, with a reasonable sum held in reserve to seed the next convention. (See “Al-Anon and Alateen Conventions.”)

### ***Mini Conventions, Share-a-Thons, Workshops or Other Get-Togethers***

Members may choose to plan get-togethers for public information, service, or other sharing purposes. Chairpersons of these events are not necessarily chosen by, or members of, their Area World Service Committee (AWSC); to avoid calendar conflicts and encourage unity, they can alert the District Representative, the Area Delegate, or some other member of the AWSC, making known their dates, purposes, etc.

### ***Alateen Participation***

Since Alateen is part of the Al-Anon fellowship, its members are to be included in Al-Anon activities wherever possible. It is within

---

\* No longer available from the WSO, but may be available in your Area.

the autonomy of the Planning Committee to make the decision whether or not the Alateens have a separate agenda.

### ***Films***

Sometimes films are used at large meetings and conventions for entertainment between meetings and workshops. Because of the Sixth Tradition of nonendorsement, the use of Conference Approved films is suggested.

### ***Videotaping or Filming***

In keeping with Tradition Eleven, videotaping or filming at conventions is not recommended.

# Alateen Policy

## Area Alateen Safety and Behavioral Requirements

---

***Note:** World Service Conference Alateen policies that are approved for the World Service Conference structure must adhere to the 2003 Alateen Motion from the Board of Trustees. The 2003 Alateen Motion is a legal resolution of the Board of Trustees of Al-Anon Family Group Headquarters, Inc. and cannot be changed by a World Service Conference Motion. Just as our Al-Anon/Alateen policies and procedures must be in keeping with our Twelve Steps, Twelve Traditions, Twelve Concepts of Service, and the World Service Conference Charter, Alateen policies and procedures for the World Service Conference structure must also comply with the 2003 Alateen Motion. Only the Board of Trustees can amend or alter the 2003 Alateen Motion.*

---

Each Al-Anon Area in the World Service Conference Structure has Area Alateen Safety and Behavioral Requirements in place which meet or exceed the minimum requirements set by the 2003 Alateen Motion from the Board of Trustees (available from the WSO). The Area's Requirements include minimum requirements for Al-Anon Members Involved In Alateen Service (AMIAS), Alateen meetings, and Alateen participation in conferences, conventions, and other events. In order to use the Alateen name, the Area, all Al-Anon Members Involved in Alateen Service, all Alateen members, and all meetings and events with Alateen participation must be in compliance with the Area's Alateen Safety and Behavioral Requirements. Each Area's Alateen process details the steps that must be taken to meet its requirements.

An Al-Anon Member Involved in Alateen Service (AMIAS) is an Al-Anon member who is currently certified through their Area's Alateen process and is therefore eligible to be directly responsible for Alateens while being of service to Alateen. AMIAS may be certified by more than one Area; however, they must first be certified by the Area in which they reside. AMIAS may serve as Alateen Group Sponsors, chaperones, drivers, or other roles as outlined in their Area's Alateen Safety and Behavioral Requirements. Area Alateen Coordinators are required to be certified AMIAS; the Area determines which other service roles require certification.

Al-Anon members who are also members of A.A. may be certified as AMIAS and serve as Alateen Group Sponsors by virtue of their Al-Anon membership, in accordance with their Area's Alateen Safety and Behavioral Requirements. Emphasis should be placed on the Al-Anon interpretation of the program at all times.

## **Area Alateen Process**

Each Area has its own process to implement and maintain its Alateen Safety and Behavioral Requirements, including the paperwork required for certification of AMIAS, registration of Alateen groups, and events with Alateen participation.

Details on an Area's Alateen process are available from the Area Alateen Coordinator, Area Alateen Process Person (AAPP), another Area trusted servant, or your District Representative (DR). To connect with Area trusted servants, contact your Group Representative (GR), DR, or the World Service Office.

## **Starting an Alateen Group**

In order to use the Alateen name, groups must register with the World Service Office through their Area's Alateen process. Each meeting must have an Alateen Group Sponsor (two are recommended) in order to keep the focus on the Al-Anon interpretation of the program. Every Alateen Group Sponsor is a minimum of 21 years old, currently attending Al-Anon meetings and an active Al-Anon member for at least two years in addition to any time spent in Alateen. (Additional requirements may be set by the Al-Anon Area.)

Once registered, every Alateen group abides by the Alateen Traditions and is open to all Alateen members.

## **Alateen Group Sponsors**

An Alateen Group Sponsor is an adult member of Al-Anon who attends Al-Anon meetings regularly, is currently certified as an Al-Anon Member Involved In Alateen Service through their Area's Alateen process, and has made a commitment to be of service to an Alateen meeting on a regular basis. Alateen Group Sponsors encourage the Alateens to take responsibility for their own meetings and to share their experience, strength, and hope with each other.

Alateen Group Sponsor(s) must be present to hold an Alateen meeting, as outlined in the Area's Alateen Safety and Behavioral Requirements. When a regular Sponsor is not available, another Al-Anon member who is certified through the Area's Alateen pro-

cess can serve as an Alateen Group Sponsor. When there are no certified Al-Anon members available to be of service to the Alateen group, the Alateens are welcome to attend an Al-Anon meeting. Whenever young people (minors) attend an Al-Anon meeting, the Al-Anon group would be responsible for prudent safety measures for them just as it is for the safety of Al-Anon members attending (e.g. making sure no one is left alone at the facility, etc.).

## **Alateen Personal Sponsors**

Alateen Group Sponsors and other Al-Anon members do not serve as personal Sponsors to individual Alateens. Alateen members are encouraged to sponsor each other in a peer-to-peer relationship.

## **Who Attends Alateen Meetings**

Alateen meetings are closed meetings; ordinarily only Alateen members, prospective members, and the Area-certified Alateen Group Sponsors affiliated with the group attend. However, designated Area trusted servants may occasionally attend the meeting as a resource to the group per the Area's Alateen Safety and Behavioral Requirements. Any potential Alateen Group Sponsor must go through the Area's certification process prior to visiting an Alateen group.

An Alateen group may hold an occasional (annual, biannual, or quarterly) public outreach open meeting for the purpose of introducing Alateen to Al-Anon members, A.A., professionals, teachers, and other members of the community.

## **Alateen Membership/Age Range**

As the name implies, Alateen is designed for members in their teens. Family members below teen years might not be ready for the Alateen program. Such children may have to depend on others to choose what they learn. This could lead to the development of a teaching program. "Teaching" is not compatible with the Al-Anon principle of sharing. There are, however, younger children who can benefit from the Alateen program, which requires the ability to participate in a shared learning experience.

It is within the autonomy of each Alateen group to lower the age limit or divide into groups according to age. Whatever the decision, all such groups will be registered as "Alateen" at the World Service Office. Members in their teen years who are legally adults agree to abide by the same requirements as minor Alateens when they attend Alateen meetings and events. Alateen members in the

upper teen years are encouraged to begin attending Al-Anon as well as Alateen meetings; young people beyond the teen years attend Al-Anon meetings.

## **Funding/Seventh Tradition**

It may be difficult for a new Alateen group to meet all its expenses and needs. The local Al-Anon group(s) or district may provide literature or funds to help the group get started, with the goal of the Alateen group becoming fully self-supporting as soon as possible.

## **Alateen in Schools and other Facilities**

Alateen meetings in schools, hospitals, juvenile centers, and other professional settings can give children and teens access to Alateen who might not otherwise be able to attend. Such meetings are often only open to the young people in those schools or facilities. Generally, members will meet with the facility staff to explain Al-Anon/Alateen principles of anonymity and confidentiality and learn about the facility's requirements. The goal is to reach a mutually beneficial arrangement in keeping with the Area's Alateen Safety and Behavioral Requirements and the Traditions. Some facilities require that a counselor or other staff member sit in the meeting; in such cases, the meeting can be considered open only to required personnel in a limited access setting. (See the Guideline *Alateen Meetings in Schools* [G-5].)

## **Events with Alateen Participation**

In order to use the Alateen name, any event or gathering with Alateen participation (including Alateen conferences, Al-Anon/Alateen conventions, Area Assemblies, multi-Area events, and A.A. events with Al-Anon and Alateen participation) must be in compliance with the Alateen Safety and Behavioral Requirements of the Area in which it is held. (See "Area Alateen Process.")

Areas, districts, groups, or conferences may have fundraising events to provide full or partial scholarships for Alateens or Alateen Group Sponsors who may not otherwise be able to attend. In keeping with the Seventh Tradition, contributions for attending the conference should be solicited only from within Al-Anon. (See "Financial Matters/Fundraising.") (See Guidelines *Alateen Conferences* [G-16], *Area Conventions* [G-20], and *Participation in Area A.A. Conventions* [G-7].)

# Anonymity

The experience of our groups suggests that the principle of anonymity—summed up in Tradition Twelve as “the spiritual foundation of all our Traditions”—has three elements: There is anonymity as it applies outside Al-Anon/Alateen, governing our contacts with general public, the media, and professionals; anonymity within the fellowship; and anonymity as it contributes to our personal growth.

## Anonymity Outside Al-Anon/Alateen

### *Anonymity and the General Public*

When dealing with the general public it is important to use discretion in revealing one’s Al-Anon/Alateen membership. In settings where there is no media involved (health fairs, speaking to community groups or schools, etc.), members are free to use their full names, if they are comfortable doing so.

### *Anonymity and the Media*

Tradition Eleven gives a specific guideline: “we need always maintain personal anonymity at the level of press, radio, films, and TV.” It is Al-Anon/Alateen policy to interpret Tradition Eleven to include the Internet as well as all forms of evolving public media. Personal anonymity in the media guards the fellowship from the Al-Anon/Alateen member who may be tempted to seek public recognition.

When speaking or writing as an Al-Anon/Alateen member in any form of press, radio, films, TV, Internet, or other evolving public media, members use only their first names and last initial or pseudonyms. Members can also speak without identifying themselves or sign articles “Anonymous.”

Photographs, video, film, or Web postings in published or broadcast media should not reveal full face images of those identified as members.

On any Web site accessible to the public, whether an Al-Anon site or not, full names, phone numbers, or other identifying information are not posted, if they are identified as belonging to an Al-Anon/Alateen member.

(See “Anonymity in Al-Anon/Alateen Publications” in the “Anonymity Within Al-Anon/Alateen” section.)

### *Anonymity and Professionals*

It is important to make Al-Anon/Alateen known through our public outreach work with the many types of professionals who



come into contact with families suffering from the effects of someone else's drinking. When working with professionals, Al-Anon and Alateen members are more credible and effective when they give their full names and contact information. While personal anonymity is not required in outreach to professionals, it is helpful to inform the professionals of the importance of anonymity and confidentiality in Al-Anon/Alateen.

Note: Alateen members must comply with local laws and their Area Alateen requirements regarding personal anonymity in all public outreach work.

### ***Electronic Communication Outside of Al-Anon***

E-mail provides a quick and easy way to communicate the Al-Anon/Alateen message to the media and professionals. Members' business e-mail addresses should not be used for Al-Anon/Alateen outreach, as they could imply affiliation, and may not be confidential to the member.

Web-based communication, such as on-line audio/visual materials (e.g., Web casts or podcasts), social networking sites, and blogs, provides members with easy access to distribute information about Al-Anon/Alateen recovery to a large audience. In keeping with Tradition Eleven ("Our public relations policy is based on attraction rather than promotion; we need always maintain personal anonymity at the level of press, radio, films, and TV. We need guard with special care the anonymity of all AA members."), members who use this type of communication outlet must maintain their personal anonymity and that of any Al-Anon/Alateen or A.A. member, as the Internet is a form of media.

### **Anonymity Within Al-Anon/Alateen**

Members use their full names within the fellowship when they wish. The degree of anonymity a member chooses (first name, pseudonym, or full name) is not subject to criticism. Each member has the right to decide.

Regardless of our personal choice, we guard the anonymity of everyone else in the fellowship, Al-Anon/Alateen and A.A. This means not revealing to anyone—even to relatives, friends, and other members—whom we see and what we hear at a meeting.

Anonymity goes well beyond mere names. All of us need to feel secure in the knowledge that nothing seen or heard at a meeting will be revealed. We feel free to express ourselves among our fellow Al-Anon members because we can be sure that what we say will be held in confidence.

## ***Anonymity at Open Meetings and Al-Anon/Alateen Events***

At open Al-Anon meetings, group anniversaries, conventions, or workshops where non-members may be present, Al-Anon and Alateen members are free to decide how much anonymity they prefer. It is well to begin these meetings with a brief explanation of the Eleventh and Twelfth Traditions. One suggestion is as follows:

There may be some who are not familiar with our Tradition of personal anonymity in any form of press, radio, films, TV, Internet, and other electronic media.

If so, we respectfully ask that no Al-Anon, Alateen or A.A. speaker or member be identified by full name or picture in published, broadcast, or Web-posted reports of our meeting.

The assurance of anonymity is essential to our efforts to help other families of alcoholics, and our Tradition of anonymity reminds us to place Al-Anon and Alateen principles above personalities.

At any function that records its speakers, members need to be aware that some recorders have Web sites that are open to the public. If speakers use full names, their sharings, including full names, could be posted, which violates the principle of anonymity.

### ***Anonymity in Service***

In Al-Anon/Alateen service positions (Group Representatives, District Representatives, Coordinators, World Service Conference members, etc.), it is practical to use full names and addresses to facilitate communication.

### ***Confidential Mailing Lists***

Confidential mailing lists are maintained throughout our service structure by groups, districts, Areas, and the WSO. Care must be taken that members' identifying information from these confidential lists is not made available to the public in published materials or posted on public Al-Anon Web sites.

### ***Service Communication***

Service communication via e-mail is expedient and efficient, but care and common sense must be taken in its use, particularly in forwarding messages. Use of blind copies protects members' anonymity. Members should select with care the e-mail address(es) they use to conduct Al-Anon/Alateen business. It is recommended not to use members' full names in them. Business e-mail addresses might not provide privacy and could imply affiliation.

- Current Mailing Addresses (CMAs), Group Representatives (GRs), and other trusted servants sending information by e-mail to group members take care in the wording of e-mail subject lines and use an e-mail address that protects anonymity as the e-mail addresses to which they are mailing may not be private.
- E-mail addresses of trusted servants are assumed to be private. Electronic correspondence sent among the links of service may include the name Al-Anon or Alateen.

As postal correspondence is delivered by public means, letters (including the return address) to an Al-Anon or Alateen member should never have the name Al-Anon or Alateen on the envelope. The WSO uses “AFG, Inc.” on envelopes sent to members in order to protect anonymity.

### ***Anonymity in Al-Anon/Alateen Publications***

In all publications available to the general public, personal anonymity is maintained. Although the WSO requests that member submissions to WSO publications include full names, addresses, and phone numbers, the WSO publishes the material signed with first name and initial, “Anonymous,” or a pseudonym. Service arm publications follow the same publishing policy when distributed outside the fellowship.

Publications and other materials meant for members (such as flyers, reports, letters, e-mail messages, newsletters) that identify members by full name or provide members’ phone number or address can be posted on Al-Anon/Alateen password-protected Web sites. Posting material meant for members on Web sites that are not password-protected could result in publishing a member’s full name, which violates the principle of anonymity. (See “Anonymity and the Media” in the “Anonymity Outside of Al-Anon/Alateen” section.)

### **Anonymity in Our Personal Growth**

In Al-Anon/Alateen we share as equals, regardless of social, educational or financial position. Common sense in the use of anonymity provides freedom and the security each member is assured in Al-Anon/Alateen. Our spiritual growth has its roots in the principle of anonymity. Each member has the right of decision regarding personal anonymity within the fellowship, which we respect whether the member is attending meetings, not attending meetings, or deceased. (See “Public Outreach.”)

# Financial Matters

## Contributions to WSO

In keeping with our Seventh Tradition, Al-Anon is supported by members' contributions and from the sale of our literature. All contributions are used to meet expenses for worldwide services, including a portion of the operating expense of the World Service Conference. All income from contributions and literature sales is allocated to the General Fund. Contributions to the WSO cannot be earmarked for special purposes unless recommended by the World Service Conference. (Also see "Outside Contributions.")

### *By Individual Members*

#### **Direct Contributions**

In any calendar year, an Al-Anon member may contribute to the WSO any amount up to one percent of the total revenue of the WSO General Fund as identified in the previous year's audit. (Also see "*Incorporation/Taxes, Al-Anon Family Group Headquarters, Inc.*" regarding charitable deductions.)

Members may authorize a monthly deduction from their bank account. (Contact the WSO for details.)

**Combined Giving Campaigns.** Members may contribute to the WSO via a combined giving campaign. Matching funds from non-members cannot be accepted. (Contact the WSO for details.)

**Birthday Plan.** In honor of their Al-Anon/Alateen birthday, members may express their gratitude by contributing an amount for each year's membership. (Contact the WSO for details.)

**Memorial Contributions.** Any Al-Anon or Alateen member may make contributions to the WSO in memory  
*...continued on page 127*

**Quarterly Appeal.** The quarterly appeal gives each member an opportunity to participate in Twelfth Step work beyond the group level. Since the WSO does not maintain a list of all members of Al-Anon, quarterly appeal letters are mailed to the groups. It is requested that the letters be read at two successive meetings, followed by a special collection in addition to the regular group collection.

The 1966 World Service Conference voted that three letters of appeal for individual contributions be sent annu-

ally from the WSO to Al-Anon/Alateen members in the United States and Canada. In 1998, the World Service Conference voted to increase the appeal frequency to quarterly (February, May, August, and November). In November the appeal is extended to members of groups worldwide.

### **Bequests**

The WSO may accept a *one-time* bequest from an Al-Anon member in any amount, provided its use is not restricted by the donor. Bequest amounts, up to ten percent of the total revenue of the WSO General Fund as identified in the previous year's audit will be placed in the General Fund. Members may give more than the ten percent; however, the portion of the bequest above ten percent will be reported separately on the financial statements. The World Service Conference will authorize the use of these excess amounts and the authorized expenditures will be administered by the Board of Trustees. These excess amounts are not available for general purposes, unless further authorized by the Conference. (Contact the WSO for details.)

### **By Groups and Other Service Entities**

#### **Al-Anon/Alateen Groups**

Groups may make donations to the WSO on a regular basis without limit.

#### **Al-Anon Service Arms**

Districts, Al-Anon Information Services (Intergroups), Literature Distribution Centers, Areas, General Service Offices, and other Al-Anon service entities may also contribute directly to the WSO without limit.

#### **Al-Anon and Alateen Conventions**

A portion of the funds derived from Al-Anon and Alateen conventions may be contributed to the WSO. (See "Conventions," "Distribution of Proceeds.")

#### **A.A. Conferences/Conventions**

Contributions received from A.A. conferences/conventions that are offered to Al-Anon as acknowledgment of its participation in these functions may be accepted by the WSO or its service arms.

### **Reserve Fund**

Al-Anon Family Group Headquarters, Inc. has the right and obligation to establish and maintain a Reserve Fund. This fund, established in 1970, has a two-fold purpose: ensuring the continuation

of Al-Anon's essential services and the funding of special projects. (See *Reserve Fund Guideline* [G-41].)

## **Discounts and Services**

WSO and other Al-Anon service entities may accept discounts or services that are routinely available to other non-profit organizations (e.g. non-profit postal rates, free placement for public service announcements, etc.). Discounts may not be accepted if the discount is given only to Al-Anon and not to other non-profit organizations.

## **Fund Raising**

Many groups, districts, Areas, Information Services, Conventions, Conferences, Assemblies, or other gatherings of Al-Anon/Alateen members often raise funds to provide services.

Fund-raising activities such as potluck suppers, dances, or other social events are conducted only within the fellowship and in agreement with the groups directly involved. If, however, such events are open to the public, use of the name Al-Anon or Alateen would violate the spirit of our Traditions.

## **Outside Contributions**

Al-Anon and Alateen groups do not accept contributions of money, goods, or services from outside the Al-Anon membership in order to adhere to the Seventh Tradition of full self-support.

## **Avoiding Commercialism**

Raffling various articles at meetings or other gatherings is a matter of autonomy (see "Selling Products/Chances"), but to avoid commercialism in the fellowship, it is suggested that these items relate in some way to our spiritual principles. Items such as Al-Anon or Alateen books, subscriptions to *The Forum*, or the donated products of the creative efforts of individual members are suggested. (Also see "Raffle/Lottery Tickets.")

## **Program-Related Jewelry and Trinkets**

The WSO does not stock or offer program-related jewelry or trinkets for sale because these actions could divert our service office from our primary purpose.

In keeping with Tradition Six, the WSO does not provide lists of suppliers for articles associated with the fellowship, e.g., plaques, jewelry.

## **Selling Products/Chances**

### ***Selling Products at Meetings/Conventions/Conferences***

Tradition Five states that the one purpose of each Al-Anon group is to help families of alcoholics. Therefore, it is inappropriate for an individual or outside entity to use Al-Anon meetings or other Al-Anon events as a marketplace before, during, or after these gatherings for the sale of services or products.

### ***Selling Products at A.A. Meetings***

In keeping with Tradition Seven, Al-Anon and Alateen members should refrain from soliciting or selling any products at A.A. meetings.

### ***Raffles/Lottery Tickets***

Raffles/lotteries are subject to national, state/provincial, and local laws.

U.S. federal law and Canadian federal law make it illegal to send lottery tickets through the mail.

Governmental regulations may prohibit solicitation of ticket money by letter or by the sales of chances on a prize. Similar restrictions may apply outside the United States and Canada.

There may also be other state or provincial laws which regulate the use of fund raising involving the sale of chances or tickets by charitable organizations. Since groups, districts, and many Areas are not registered as charities with state/provincial or federal authorities, these laws could prohibit such sales.

Local statutes must also be investigated and complied with in order to prevent individual members and Al-Anon as a whole from becoming involved in public controversy.

After determining that the proposed raffle and/or lottery is legally permitted within the Area where it is to be held, additional precautions need to be taken so that we are not diverted from our primary purpose and do not imply endorsement. Distribution and sale of raffle/lottery tickets should be limited to Al-Anon/Alateen meetings and events. (Also see “Fund Raising” and “Selling Products and Chances.”)

## **Payment for Speaking**

In keeping with the Eighth Tradition, Al-Anon speakers are reimbursed for expenses only. When a member is speaking to an

outside organization, the speaker may suggest funds in excess of expenses be used by the organization for the purchase of Conference Approved Literature (CAL) for distribution by the organization as an educational service.

## **Public Meetings**

A basket may be passed at open meetings to which the public is invited. In keeping with the Seventh Tradition, it is clear that the fellowship is dependent on its own voluntary contributions. Reading the Preamble and the Traditions clarifies this principle.

## **Use of Group Funds**

### ***Rent and Other Group Expenses***

Our Tradition of self-support suggests that the expenses for the group's operation such as rent, literature, insurance, supplies, post office box rental, Group Representative, and Information Service Representative expenses be met first. Remaining funds may be used to support local and Area structures and the World Service Office.

At locations where rent may not be accepted, a supply of Al-Anon/Alateen Conference Approved Literature and local meeting schedules may be provided to the facility as an appropriate alternative.

### ***Gifts to Members***

Group funds are used for group purposes only, not for personal gifts to members.

### ***Baby-Sitters***

Some meetings are attended by members who must bring children. Using group funds or taking a special collection to pay for a baby-sitter at the meetings is within a group's autonomy. Paying for this type of service does not violate Traditions, since avoiding disruption of a meeting benefits the group as a whole.

### ***Donations to Outside Agencies***

In keeping with our Sixth Tradition, group funds are to be used for Al-Anon/Alateen purposes only. Groups may use their funds to purchase Al-Anon/Alateen literature to donate to outside agencies, activities, and programs for public outreach.



# Local Services

## Naming a Service

Al-Anon Information Services (AIS) call themselves Information Services, Service Centers, Information Centers, or Intergroups. The name “Literature Distribution Center” (LDC) is used for services that provide Al-Anon/Alateen members with access to Al-Anon/Alateen materials. A combined AIS and LDC will be given one registration number at the WSO.

The term “Al-Anon Central Services” is reserved for AIS/LDCs serving entire states, provinces, or Areas. Al-Anon General Services refers to structures serving countries other than the United States and Canada.

## Answering Services

The term “answering service” is usually used for service entities that handle only Twelfth Step telephone calls. The decision to implement and support this service is within the autonomy of the groups it serves.

## Information Services (Intergroups)

### *Requirements for Registration at the WSO*

The WSO registers an Information Service (Intergroup) when it meets the following requirements:

- Has a title indicative of the nature of its operation, e.g., “Al-Anon Information Service.”
- Acquires a post office box number or an office address.
- Maintains a listing in the local telephone directory.
- Conducts activities in addition to Twelve Step telephone calls, for example: works with local Al-Anon/Alateen service committees; arranges group exchange meetings; publishes meeting lists; and performs any other function as outlined in “Groups at Work.”

## Getting in Touch with Al-Anon/Alateen (S-23)

Al-Anon Information Services and offices worldwide that meet the above requirements are listed in this publication. Since individuals’ names, addresses, or telephone numbers are not disclosed, this listing can be used by the membership as well as the public and professional community. Each proposed and newly registered group receives a

complimentary copy. Additional copies can be ordered. (See “Locating Meetings,” and “World Directories of Al-Anon Family Groups.”)

### **Cooperation**

Chairpersons of local service committees should communicate with the respective Area Coordinator.

### **Employees in Al-Anon Services**

Tradition Eight states that “Al-Anon Twelfth Step work should remain forever nonprofessional.” Therefore, any Al-Anon member who is gainfully employed in an Al-Anon service does not serve as a volunteer in a policy-making position, such as Group Representative (GR), District Representative (DR), Area Assembly Officer or Coordinator, Delegate, or WSO Trustee.

### **Autonomy of Groups**

In keeping with the Traditions and Warranty Five of Concept Twelve (see Concept Twelve in “Al-Anon’s Twelve Concepts of Service”), local, Area, or WSO service entities have no authority to close a group or engage in other punitive actions against a group because they disapprove of the manner in which a group practices the Al-Anon program.

# Conference Approved Literature and Service Tools/Materials

## Conference Approval

### *What It Is*

Conference Approval is the process for development of recovery literature (including recovery literature with a service focus) that reflects the group conscience of the Al-Anon Family Groups through actions taken by the World Service Conference. The conceptual ideas recommended by the World Service Conference are delegated to the WSO Literature Committees for implementation. Each item, when completed, bears the Conference Approval seal.



### *How Material Receives Conference Approval*

Al-Anon Conference Approved material grows out of need. Whether the need is for recovery literature or for recovery literature with a service focus (hereafter both referred to as Conference Approved Literature), the process of Conference Approval ensures that designated Al-Anon members, Delegates, WSO staff, and volunteers will review the material before publication and/or production. Many members' participation in the Conference Approval process guarantees the fellowship that the material is an expression of Al-Anon principles. Proposals of new material and major revisions of existing material are brought to the World Service Conference for recommendation and approval. Service committees may propose material with a service focus. Proposed manuscripts and/or content of Conference Approved Literature are reviewed by a Literature Committee. As a final step, the Executive Director, the Chairperson of the Policy Committee, and four other members of that Committee review all new pieces and major revisions of existing material before they are approved. The Board of Trustees through the Executive Director authorizes minor revisions.

### *Material Written by Al-Anon/Alateen Members*

The actual writing is done by Al-Anon/Alateen members. Material submitted is subsequently coordinated and edited for literary style by Al-Anon members who may be professional writers. In keeping with the spirit of Al-Anon, the full name of any individual

member does not appear in the title of Al-Anon/Alateen material, nor is authorship acknowledged. All published material becomes the sole property of the Al-Anon Family Group Headquarters, Inc., on behalf of the Al-Anon/Alateen fellowship.

**Material Written by Non-members**

A few items were not developed in the above manner. Such exceptions were made when a booklet, talk, or article by a non-member met a specific need, and then only with Conference Approval. As a necessary courtesy, credit was given to the author or the organization where the material originated

**WSO Service Tools**

Service tools and materials are created by a World Service Office service department, committee, or as the result of a Conference discussion. They are designed to assist members at meetings and in conducting Al-Anon/Alateen service. Service tools are developed by staff or committees and are subject to Executive Committee approval. As a final step, the Executive Director, the Chairpersons of the Board of Trustees and Executive Committee, and designated Policy Committee members approve the text of service tools.

**Al-Anon/Alateen Service Manual**

“Al-Anon and Alateen Groups at Work” is updated on a regular basis at the World Service Office. Approval for additions and revisions to other parts of this *Manual* is given by vote at the World Service Conference.

**Authorization for Production**

Production of new material to be added to the list of Conference Approved material that has been recommended and approved by the World Service Conference must be authorized by the Board of Trustees.

**Identification of Al-Anon/Alateen Publications**

The original seal, with the letters “AFG” in the circle and the words “World Service Conference” within the triangle, appears on, and is reserved for, all Al-Anon/Alateen Conference Approved Literature and material with the words “Approved by World Service Conference.” Service tools carry the Al-Anon logo and indicate production by Al-Anon Family Group Headquarters, Inc. (See “Symbols.”)



## Use of Material at Al-Anon Meetings

To keep Al-Anon's message in focus and encourage unity, only Al-Anon/Alateen Conference Approved Literature (CAL) and Al-Anon/Alateen service tools are displayed, distributed, and used at Al-Anon and Alateen meetings, including meetings at conferences and conventions. These items reflect the informed group conscience of the Al-Anon Family Groups as expressed by its World Service Conference since 1961.

While individuals may use whatever they find helpful as part of their personal recovery outside of meetings, Al-Anon does not evaluate or recommend anything other than Al-Anon materials. When sharing at meetings, members limit any mention of outside material to a brief reference.

A.A. literature is not used at Al-Anon meetings because it is written for and from the viewpoint of alcoholics and is not Al-Anon/Alateen Conference Approved Literature. Reliance on opinions expressed in A.A. and other outside materials can distort the Al-Anon approach.

Conference Approved Literature provides a unified view of Al-Anon/Alateen to members, professionals, other individuals, and outside agencies. Service tools produced by the World Service Office reflect the Al-Anon/Alateen service structure and the shared experiences of our membership. (See *Al-Anon Spoken Here* [P-53], *Why Conference Approved Literature?* [P-35], and the "Three Obstacles to Success in Al-Anon," as found in *Alcoholism, the Family Disease* [P-4] and "Groups at Work" [P-24].)

### The Forum

*The Forum* is the monthly magazine in which Al-Anon and Alateen members share their experiences. It is "The Voice of the Fellowship," a forum where individual members and groups can be heard. *The Forum* staff at the WSO, with assistance from a volunteer committee, edits the letters and articles sent from all over the world. This assures a publication that a broad-based international audience can understand and use for growth in the program. It also offers meeting ideas and materials for use in group discussions.

*The Forum* can be used, and is encouraged to be used, by all members and groups for meetings. *The Forum*, as a concept, is Conference Approved, but it is not possible for each issue to follow the full procedure for Conference Approved Literature. Sharings received for *The Forum* are reviewed for their fidelity to the Al-Anon program and principles by a volunteer committee and/or *The Forum*

staff. Time-sensitive articles, such as editorials, interviews, “Inside Al-Anon,” etc., may be reviewed by *The Forum* staff.

Since it is copyrighted material, the WSO does not grant permission for substantial reprints from *The Forum* in Area, district, or other service arm newsletters in the U.S. and Canada. However, it is permissible for all newsletters to reprint any articles that appear in the “Inside Al-Anon” section of *The Forum*. Newsletters of other countries may, upon informing the WSO, use additional *Forum* material if they give proper credit line in their publication. *The Forum* is available by subscription.

## Other WSO Publications

### **Timely Reprints**

In 1977, the World Service Conference affirmed the continuation of the use by selected committees of articles and reprints of articles from major outside publications. The use of such timely pieces does not endanger Tradition Six regarding endorsement; rather it enhances the public’s view of the Al-Anon program of recovery and helps service committees spread the message of Al-Anon’s value as a community resource. These committees may also reprint articles from *The Forum*, WSO newsletters, or other WSO publications when interest in a particular subject is indicated. Such reprints can be proposed for development as a permanent piece of CAL if a strong interest in them is evidenced. Because of their timeliness, reprints are often distributed between Conferences. These items are reviewed for appropriateness, use, and distribution by the service committees of origin as well as appointed members of the Policy Committee. These reprints are identified by the Al-Anon/Alateen logo/and carry the words “reprinted and distributed by Al-Anon Family Group Headquarters, Inc.”

### **Guidelines**

All guidelines are a collection of shared experience and can be adapted by the membership. Guidelines can be identified by this Al-Anon/Alateen logo and the words “compiled and distributed by Al-Anon Family Group Headquarters, Inc.”



### **The Conference Summary**

*The Conference Summary* is the annual report to the groups about the World Service Conference and World Service Office activities. It is distributed free to Area World Service Committees and to current and past Conference members. Groups and individuals may purchase copies at a nominal cost.

## **WSO Newsletters**

All WSO newsletters and other materials are developed in response to the needs of our membership. WSO staff and committees review the content. “Inside Al-Anon” in *The Forum* keeps groups attuned to worldwide Al-Anon activities and the latest material available from the WSO. A free copy of *The Forum* is sent to each English-speaking registered group in the World Service Conference structure and to English-speaking groups worldwide that are not part of a national service structure. “Inside Al-Anon,” along with *Alateen Talk* and *Area Highlights*, is copyrighted. Portions of these newsletters, however, may be reproduced in Area newsletters provided proper credit information is given (for example, “From *Area Highlights*, Summer 2010; Reprinted with permission of Al-Anon Family Group Headquarters, Inc.”).

## **World Directories**

Members may obtain all information formerly published in the World Directories, including names of specific groups, group contact names and telephone numbers, and information regarding the World Service Office and Area trusted servants, from either the Area Delegate, Group Records Coordinator, or the WSO. (See “Locating Meetings.”)

## **Copyrights**

Al-Anon/Alateen Conference Approved Literature (CAL), *The Forum*, and most service materials/tools are copyrighted. The WSO does not grant permission for substantial reprints of CAL in Area, district, or other service arm newsletters, or to outside publications, in the U.S. and Canada. It is not necessary for Al-Anon/Alateen service arms to obtain permission to excerpt items of interest from *Area Highlights*, *Alateen Talk*, the “Inside Al-Anon” section of *The Forum*, or from service tools.

Whenever a violation of a copyright comes to the attention of the Board of Trustees, it is the responsibility of the Board, through its duly appointed representative, to notify the violator. This is necessary in order to avoid invalidation of the copyright.

## **Symbols/Logos**

The three symbols shown below are registered as Al-Anon “marks” with the U.S. Patent and Trademark Office. Use of these marks for other than Al-Anon/Alateen purposes or any alteration of these symbols endangers their legal status.

The Al-Anon/Alateen logo with AFG in the circle is a popular means of identification at conventions and joint fellowship affairs.

The logo without the AFG was adopted by the WSO for easy identification of stationery, service tools, and other Al-Anon/Alateen material. Al-Anon/Alateen service arms (such as Areas, districts, and Information Services) and conventions with Al-Anon/Alateen participation may use this logo without alteration for identification on printed materials.

The original logo, accompanied by the words “Approved by World Service Conference Al-Anon Family Groups,” identifies Conference Approved Literature. (See “Identification of Material.”)



## Authorization to Publish and Reprint

### *Publishing*

The World Service Conference has authorized Al-Anon Family Group Headquarters, Inc., also known as WSO, to be the sole publishing agency for the fellowship worldwide. Therefore, no Al-Anon group, Information Service (Intergroup), Literature Distribution Center, or any other service arm may produce or publish its own literature or sell outside literature and/or materials. (The only exceptions are found under “Outreach Publications—AIS/Area” and “Outreach Publications International” in the “Public Outreach” section.)

### *Requests to Reprint*

Permission to reprint extensively from our publications is not granted in the United States and Canada to any individuals, within or outside of our membership, or to any outside agency. Forms to request reprint permission are available from the WSO. Each request received at the WSO to reprint limited excerpts will be evaluated on its merits and the circumstances. Requests for permission to reprint limited excerpts from copyrighted Al-Anon/Alateen material must include at least four paragraphs from the proposed new text. The new text should include the two paragraphs of the author’s/writer’s/editor’s material immediately prior to the excerpt and the two paragraphs of the author’s/writer’s/editor’s material immediately following the excerpt. When reprint permission is granted by the WSO the appropriate credit line must accompany



the excerpt. Two copies of the published material/document must be sent to the WSO on or before publication. The WSO terminates permission to reprint if the volume is not published within two years from the date of the request.

### ***Countries Outside United States and Canada***

Permission to publish CAL is extended only to national Al-Anon General Service bodies in countries outside the United States and Canada. Occasionally such permission is extended to Al-Anon Central Service Committees, Centers, or even a single group, with the provision that the right to publish be relinquished when a general service body is formed.

### ***Granting Permission to Translate CAL***

All translations of Al-Anon CAL to other languages are to be submitted to the WSO for review and approval before permission to print or reprint is granted.

### ***Service Tools/Material and Electronic Publishing***

A listing of Al-Anon/Alateen service tools/materials that may be posted on Web sites is found on the WSO Members' Web site: [www.al-anon.alateen.org/members](http://www.al-anon.alateen.org/members). A credit line "Reprinted by permission of Al-Anon Family Group Headquarters, Inc." is required. No other Al-Anon/Alateen copyrighted literature may be reprinted electronically without express written permission from the WSO.

## **Translations**

Al-Anon literature in translation should conform to the spirit and meaning of the original English version. Application and understanding of the Al-Anon philosophy is naturally affected by varying local customs and culture in different areas of the world. (See above, "Granting Permission.")

## **Literature Sales Outside the United States and Canada**

The WSO cannot refuse to fill orders for literature from anyone—Al-Anon members, General Service Offices, or others. It is up to the Al-Anon General Service Offices to educate their groups to the advantage of purchasing literature from them. In this way, the groups strengthen their own national general service committees.

# Public Outreach

*Much of the direction for Al-Anon's public outreach has been based on the 1966 WSC statement on public relations that has long been a part of the "Digest of Al-Anon and Alateen Policies." Many of the spiritual principles that form the foundation of Al-Anon's policy are contained in the statement included here in its entirety. Excerpts denoted in this section are marked with the symbol (❖).*

## The 1966 WSC Statement on Public Relations

Our Traditions state that our public relations policy is based on attraction rather than promotion. For clarification, the sixth World Service Conference (1966) adopted the following statement, which was reaffirmed at the 1971 WSC:

It is the consensus of the sixth World Service Conference that if Al-Anon is to continue to exist, it must continue to grow. There is no standing still without retrogression. Al-Anon must continue to grow if it is going to fulfill its primary purpose of reaching millions who need Al-Anon's help but who are not yet aware of the existence of our fellowship.

We will fulfill this primary purpose most effectively by attraction and cooperation—not promotion or affiliation. For the guidance of our fellowship here are authoritative definitions of these sometimes controversial terms:

to attract: to draw by other than physical influence; to invite;  
to draw to; to cause to approach

to promote: to push forward; to further advance, as in a  
business venture (implies "hard sell," advancement for  
profit)

cooperation: joint operation or action (implies coming  
together of two or more people to work together for a  
common goal or benefit or on a common problem)

affiliation: association or close connection; a uniting (implies  
lending one's name, endorsement, legal or financial  
association)

Al-Anon is *attracting* when it tells people why we are, what we are, what we do and how; we let them know that we are available if and when help is needed. We state the facts, which are communicated via the press, radio, TV, and films, always stressing anonymity at the public level.

Al-Anon is *cooperating* when it works with others,\* rather than alone. In working with others, our scope and contacts are broadened and we reach many more of those in need.

\*❖*Examples are federal, state, provincial, and municipal alcoholism agencies; private health agencies; law enforcement, judicial, and correctional agencies and institutions; general hospitals and state, county, or city mental hospitals; councils of churches, doctors, nurses, clergymen, social workers, educators.*

## The Philosophy and Spiritual Principles of Al-Anon's Public Outreach

Our public outreach is based on the following spiritual principles that promote unity and clarity within the fellowship as well as awareness and hope outside the fellowship. Whenever there are questions concerning public outreach, it is helpful to return to these spiritual principles for resolution:

- *Members and groups carry the message.*
- *Outreach is based on attraction, rather than promotion.*
- *Personal anonymity is maintained at the level of press, radio, films, TV, and the Internet.*
- *Cooperation and goodwill strengthen public outreach.*
- *Members continually broaden the way they carry the message by using new and innovative forms of communication.*

### **Members and Groups Carry the Message**

Carrying the message is essential to attracting new members. Our Twelfth Step suggests that members carry the message of recovery to others and make Al-Anon known in their communities.

Al-Anon members who do Twelfth Step work carry the message of Al-Anon recovery keeping in mind adherence to Tradition Eleven. There is no replacement for individual Al-Anon members carrying the spiritual message of recovery within their communities in ways that media cannot.

### **Local Public Outreach: Roles and Responsibilities**

Al-Anon members who have an understanding of the Twelve Steps and Twelve Traditions have an important role in local public outreach. They carry the message of hope through local media, and to professionals throughout their communities.

Providing speakers and literature for community events, participating and exhibiting at health fairs, placing ads in public places, and talking with local radio and TV stations to request that they play public service announcements are some local outreach opportunities.

(See also, “Members Continually Broaden the Way They Carry the Message by Using New and Innovative Forms of Communication.”)

### **Making Contact with Professionals**

To ensure that professionals are aware of Al-Anon as a credible resource for helping friends and families of alcoholics, groups, districts, and other service arms can host public meetings, inviting members of the professional community. Meeting schedules and contact information on the Web sites of Area and local service arms should contain current and accurate information. In this way, the public will have direct and ready access to information, furthering Al-Anon /Alateen’s reputation as a credible local resource.

Personal sharing with professionals is one way to carry the message of hope to others. Members may have established relationships with doctors, nurses, members of the clergy, therapists, educators, or other professionals. Every Al-Anon member is encouraged to share the benefits of Al-Anon with members of the professional community with whom they come into contact, divulging their Al-Anon membership whenever they are comfortable doing so. These one-on-one relationships provide the professional with credible evidence of the benefits of Al-Anon’s program of recovery, and may encourage them to learn more about Al-Anon and perhaps recommend the Al-Anon program to others. Al-Anon does not endorse any outside enterprise. Professionals may endorse the Al-Anon program without violating the Traditions, provided that they do not reveal Al-Anon membership.

### **National and International Public Outreach: Roles and Responsibilities**

Although Al-Anon members carry the message of Al-Anon, it is the World Service Office (WSO) that is solely responsible for creating public outreach messages beyond the local level. This ensures that there is consistency in media messages throughout the world.

The World Service Conference has designated the WSO as the sole publishing agent for the fellowship and sole producer of public service announcements (PSAs). The WSO is responsible for production and distribution of all multi-Area, national, and worldwide communications including those on the Internet.

Whenever national publicity on Al-Anon/Alateen may be of interest to local groups, they are, if possible, notified in advance by the WSO.

An Al-Anon general service structure outside the United States and Canada that has received permission from the WSO to print

Conference Approved Literature may reprint WSO public outreach materials. The general service structure is not limited in the number of public outreach pieces it can produce. The WSO reserves the right to review such items before publication or broadcast.

### **Paid Advertisements**

A group may pay for an ad in the media to make the community aware of Al-Anon and Alateen. In accordance with our Traditions, an individual member may pay for such an ad, with group approval. This payment can be considered a member's personal contribution.

Members and local service arms may pay for local advertisements, for example: billboards, screen ads at movie theaters, and transit signs. The WSO reserves the right to approve the content of the message before public placement.

### **Publicizing Meeting Locations**

Meeting information may be printed in church bulletins, newspapers, and other venues for sharing public information.

### **WSO Produced Posters**

Al-Anon/Alateen posters may be displayed on the Internet or any public place, with the permission of the place or organization. A local Al-Anon service phone number, P.O. Box, Web site, e-mail, and/or office address, may be used as a point of contact.

### **Posters and Flyers for Public Outreach for Al-Anon Service Arms**

Al-Anon Information Services and Area World Service Committees may have a need for public outreach posters that can be produced and distributed within their area of service. This could include outreach to a particular cultural group, for example. Districts, Information Services, and Areas work together on such projects so the Al-Anon message remains consistent and unity among the service arms is ensured. Service arms contact the WSO before creating a poster. The WSO has posters available for a variety of needs and topics that might meet the needs of an AIS or Area. The WSO extends permission for such posters, reserving the right to review these items before they are printed and distributed, in order to preserve Al-Anon's public outreach message. These outreach posters may appear on the Internet provided that no member's name, phone number, or other identifying information appears, so that anonymity is maintained.

Permission is not required when public outreach flyers are created for a single local event. Flyers on the Internet are accessible to the public and must protect members' anonymity.

### **Outreach Publications—AIS/Area**

Although the Conference has designated Al-Anon's WSO as the sole publishing agent for the fellowship, the WSO extends permission to Al-Anon Information Services or Area World Service Committees for the production of only one publication for public outreach for distribution solely within their area of service, reserving the right to review the publication before printing and distribution in order to preserve Al-Anon's public outreach message. To assist potential members in locating a meeting, a meeting schedule is frequently included with such a publication.

### **Outreach Publications—International**

An Al-Anon general service structure outside the United States and Canada that has received permission from the WSO to print Conference Approved Literature may reprint WSO public outreach materials. The general service structure is not limited in the number of public outreach pieces produced. The WSO reserves the right to review such items before publication.

### **Public Service Announcements**

The media (TV, radio, newspapers, etc.) offer free air time or print space to not-for-profit organizations for public service announcements (PSAs). Al-Anon provides such PSAs to inform the general public about Al-Anon and Alateen. The World Service Conference has designated the WSO as sole producer of public service announcements for the fellowship to use in public outreach work.

### **Area/Local Public Outreach Messages**

Areas and local service arms may produce and participate in public announcements, programs, broadcasts or community calendar items that are of local interest, have local impact, or reflect a local culture's needs. These may be provided to local radio, television or community cable stations. In such projects, Tradition Eleven is maintained by avoiding recognition of the participants and by the use of first names or pseudonyms. Prior to broadcast, the WSO reserves the right to review such projects for consistency with the Al-Anon message.

### ***Outreach is Based on Attraction, Rather than Promotion***

It has always been Al-Anon's approach to carry a clear and simple message about our program of recovery—that is: to let people know what we are, what we do, and how they can come into contact with us. We do this in many creative ways while avoiding high pressure tactics which distort our message of hope or bring us into public controversy.

We attract interest in Al-Anon Family Groups when we communicate what our lives were like before we came to Al-Anon, what we found in Al-Anon that helped us, and what our lives are like today. In error, we would be promoting Al-Anon if we offered promises, guarantees, personal advice, or gave the impression that we are the experts who know what is best for all families and friends of alcoholics.

### ***Personal Anonymity is Maintained at the Level of Press, Radio, Films, TV, and the Internet***

Tradition Twelve tells us that anonymity is the spiritual foundation of our entire program. Members maintain personal anonymity in all forms of public media, including press, radio, films, TV, the Internet, as well as other ways of reaching the public. It is essential that members consider Tradition Eleven as they keep public outreach messages free from personalities. No one person can ever be the sole representative of Al-Anon. The message of recovery in the media is too important to be overshadowed by a single person or group no matter how well-intentioned.

### **Anonymity at Local Events for Individuals and Service Arms**

As an organization, Al-Anon is not a secret; however, we always protect our members' anonymity. Members are encouraged to participate in local events where Al-Anon information can be shared. Participation at health fairs, speaking at schools, etc., where members might be recognized, is not considered a break in anonymity, since it does not occur at the level of press, radio, films, TV, and the Internet.

If the media is present, members who staff such events are requested to practice the principle of personal anonymity. (See "Anonymity in Public Media for Individuals and Local Service Arms.")

### **Anonymity in Public Media for Individuals and Local Service Arms**

Tradition Eleven is sustained when members maintain personal anonymity by using first name only or a pseudonym, and by appearing back to the camera, or in silhouette. This principle applies to all types of visual, audio, or print media, or in any way on the Internet, when Al-Anon/Alateen membership is revealed.

If membership is not revealed when participating in any form of public media, members can use their full name, face the camera, or appear in print.

Members avoid revealing the identity of any A.A. member.

As an individual, not an Al-Anon spokesperson, any member may write an article about the fellowship for local or national publications, and may be financially remunerated. The personal anonymity of someone writing as a member is maintained by signing anonymously or using a pseudonym. Personal anonymity also applies to members who author books or create other public communications.

### ***Cooperation and Goodwill Strengthen Public Outreach***

Al-Anon fulfills its primary purpose most effectively by cooperating with others and creating goodwill in the media and in the professional community.

Al-Anon is *cooperating* when it works with others, rather than alone. In working with others, our scope and contacts are broadened and we reach many more of those in need. However, we would give the impression of affiliation if we posted links to professional services on an Al-Anon Web site, or if we added the Al-Anon name as sponsor or co-sponsor for a commercial or community event. The concept of goodwill is simply maintaining our positive relationships and reputation as we work with others. Al-Anon exhibits goodwill when it works harmoniously in the community to provide information and carry the message of hope. In accordance with Tradition Ten, the Al-Anon fellowship does not officially respond to adverse publicity and avoids public controversy. As individuals, members may take any action they wish, as long as they do not divulge their membership or appear to be a spokesperson for Al-Anon.

### ***Members Continually Broaden the Way They Carry the Message by Using New and Innovative Forms of Communication***

In the dynamic world in which we live, we need always consider broadening our outreach efforts so that those needing our help may easily find us. This means that there is no end to the possibilities for carrying our message locally, nationally, and internationally.

In developing or conducting public outreach using new forms of communication, including emerging technologies, Al-Anon's outreach message is safeguarded by consistently referencing the primary purpose of public outreach and by applying its underlying spiritual principles.



## **Media**

Individual Al-Anon members and groups are encouraged to work with their districts, Al-Anon Information Services, and Area World Service Committees on projects for media outreach. In this way, a broad group conscience is reached and the Al-Anon message remains consistent.

## **The Internet**

The Internet is a global computer network that is in the public domain. Service arms are encouraged to post WSO public service announcements on the Internet or to create links to the WSO Public Outreach Web site. In keeping with our Legacies, Al-Anon members guard with care their own and others' anonymity, and avoid any actions or behaviors that could draw Al-Anon into public controversy or harm Al-Anon's name. (See "Social Networking—Individual Members/Groups/Service Arms." Service guidelines are available on the Al-Anon Members' Web site.)

## **Social Networking Media**

While social networking and social media Internet sites and blogs present special challenges to members and the WSO, social networking can be an important venue for carrying the message of Al-Anon as it fulfills its primary purpose of reaching millions who are not yet aware of the existence of our fellowship.

## **Social Networking—Individual Members/Groups/Service Arms**

Blogs, profiles, social networks, or other forms of social media are appropriate for public outreach. Members maintain the principle of anonymity and do not appear to speak for Al-Anon as a whole. They avoid actions, behaviors, or commentary that could draw Al-Anon into public controversy or harm Al-Anon's name and public outreach message.

The names "Al-Anon" and "Alateen" are trademark names and may not be used as usernames, logos, or identifying characteristics on profiles, blogs, or in titles of social media pages. Only Al-Anon service arms may use the Al-Anon logo. (See also "Anonymity" and "Symbols/Logos" sections of the "Digest of Al-Anon and Alateen Policies.")

## **Social Networking—WSO**

The WSO, in carrying out its responsibility for creating public outreach messages beyond the local level, will continually look for new ways to do so, using the capabilities of social networking and emerging technologies, while adhering to Al-Anon's spiritual principles.

# Incorporation/Taxes

## Al-Anon Family Group Headquarters, Inc.

Tax-exempt status was granted to Al-Anon Family Group Headquarters, Inc., our World Service Office, in 1956 under Sec. 501 (c) (3) of the U.S. Internal Revenue Code as a nonprofit corporation organized under the laws of the State of New York and operated exclusively for educational purposes. When New York State law was amended subsequently, WSO registered as a not-for-profit corporation. Tax-exempt status was similarly granted to Al-Anon Family Group Headquarters (Canada) Inc. in 1999 as a registered charity under paragraph 149(1) of the *Income Tax Act* of Canada. While a separate corporation, Al-Anon Family Group Headquarters (Canada) Inc. has the same Board of Trustees as Al-Anon Family Group Headquarters, Inc.

Contributions to Al-Anon Family Group Headquarters, Inc. or Al-Anon Family Group Headquarters (Canada) Inc. may qualify as a charitable deduction, but the World Service Office makes no judgment as to the specific deductibility of a contribution by any member.

U.S. and Canadian regulations do not contain provisions under which Al-Anon could apply for blanket exemption for its Area committees or local groups, now or hereafter formed. Only central organizations that effectively control their chapters or local units (churches, Boy Scouts, fraternal organizations) can apply for group exemption. Al-Anon Family Group Headquarters, Inc. and Al-Anon Family Group Headquarters (Canada) Inc. have no knowledge or control over Assembly or group funds; neither is therefore in a position to furnish the financial statements required to be filed annually with the tax authorities in order to maintain tax-exempt status for groups.

## National General Services

Incorporation as a nonprofit organization relates to the tax laws of the United States, which stipulate that any excess of income at the end of the year is nontaxable. Most other countries have some equivalent of the U.S. regulations governing nonprofit corporations. At the suggestion of the WSO, the General Service Boards of U.K. and Eire, Finland, Germany, and other countries have made comparable registration for such legal status with their governments.

General Service Boards should consult with local legal counsel when considering nonprofit incorporation for their organizations outside the United States and Canada. Advantages and disadvantages may vary from structure to structure.

Traditionally, organization within a group should be kept to a minimum, but worldwide unity of our fellowship depends upon creation of national Al-Anon service boards outside the United States and Canada, which should obtain legal recognition as nonprofit membership corporations or the equivalent.

Incorporation is not only for legal reasons; experience has shown it to be the best possible way of ensuring the efficiency and continuity needed to maintain Al-Anon functions throughout the country. For one thing, a corporation does not die even though Al-Anon members do. Thus, incorporation provides vital continuity.

Another advantage is the objectivity of a corporation. There is greater willingness to rotate Trustees than there is to rotate the members of a small personalized committee or working team.

Other advantages are:

- Tax exemption on literature (produced with the permission of Al-Anon's WSO), resulting in greater revenue to be used for fostering the growth of Al-Anon in the country.
- Protection of physical assets, including office equipment.
- Protection against personal liability in all business transactions.

### **Assemblies (United States)\***

The 1972 WSC recommended the following:

- All Area Treasurers be alerted to the importance of keeping accurate records that can be passed along to their successors.
- Areas seeking favorable determination of tax exemption by the Internal Revenue Service secure advice from a competent lawyer or accountant familiar with federal law. If successful, this would also enable them to obtain a nonprofit bulk-mailing permit for the Area Newsletter.
- All Areas learn what the laws in their respective states require of nonprofit organizations.

---

*\*The suggestions for Assemblies and local Service Centers in the United States may be adopted by the service units in other countries in accordance with the laws of their respective national and local governments.*

- Each Area Assembly may want to review the shared experience of other Assemblies before considering incorporation. Because state and local laws vary, all final decisions need to be reviewed by local legal and financial experts. WSO is neither equipped nor qualified to advise or aid individual Assembly Areas in incorporating or obtaining tax exemption.

### **Al-Anon Information Services (Intergroups), Literature Distribution Centers (United States)\*\***

Local Al-Anon Service Committees that perform business functions—sign contracts, rent an office, buy equipment, employ staff, print meeting lists and bulletins, or sell Al-Anon material, etc.—may want to explore incorporation in accordance with the nonprofit laws of their state. They may also need to check state and local laws regarding the collection of sales tax.

These suggestions are primarily to protect individual members, volunteers, and employees from possible personal liability. Incorporation would not give local services authority over the groups they serve.

---

*\*\*See previous footnote.*

# Al-Anon As It Relates to Others

## Alcoholics Anonymous—Cooperation

### **Local Service Centers**

Although a separate entity, Al-Anon should always cooperate with Alcoholics Anonymous. In relating to local A.A. Intergroups or central offices, Al-Anon may offer:

- To name one or two members to act as liaison and to provide current lists of group contacts for Twelfth Step referrals.
- To submit Al-Anon/Alateen meeting information for inclusion in A.A.'s local meeting list if asked to do so.
- To reimburse A.A. for any expenses incurred on Al-Anon's behalf, such as telephone calls, cost of printing meeting lists on which Al-Anon meetings are also listed, copying costs.

Where Al-Anon has not grown sufficiently strong to support its own Al-Anon Information Service office or Intergroup, it may share facilities with A.A. when offered, provided that Al-Anon meets its portion of the financial expenses (desk space, telephone, etc.).

### **Newsletters**

Where Al-Anon is relatively new, it may accept offers from A.A. to include an Al-Anon page in its newsletter. It is desirable for Al-Anon/Alateen to develop its own periodical when feasible.

### **Participating in A.A. Conventions**

Al-Anon and Alateen are usually invited to share the program in A.A. conventions. A Guideline for *Al-Anon and Alateen Participation in an A.A. Convention (G-7)* is posted on the Al-Anon/Alateen Members' Web site.

### **Twelfth Step Work**

Al-Anon performs its own Twelfth Step work in alcohol treatment centers, hospitals, and other facilities, and with professionals that work with families and friends of alcoholics. Experience has shown that cooperation with A.A. can be mutually beneficial.

## Outside Agencies

### **Speakers from the Helping Professions**

The purpose of Al-Anon is personal growth through applying the Twelve Steps and sharing our experience, strength, and hope. It is from Al-Anon and Alateen members that we hear the ideas and experiences that guide us in our personal recoveries. Outside speakers at Al-Anon and Alateen meetings may divert the focus from our own recovery to that of the alcoholic. Thus, the group tries to ensure that any occasional guest speaker be knowledgeable about the Al-Anon/Alateen program. Additionally, it is suggested that outside speakers be made aware of our Sixth Tradition in advance, and be asked to discuss an appropriate topic.

In any announcement of an Al-Anon and Alateen meeting with outside speakers, it is suggested that a statement such as the following be included: “Al-Anon is not allied with any sect, denomination, political entity, organization or institution.”

### **Shelters for Families**

In keeping with our Traditions:

- Establishing shelters is not in accordance with our Sixth Tradition, “Our Al-Anon Family Group ought never endorse, finance or lend our name to any outside enterprise . . .”
- Al-Anon members, as individuals, are free to manage such shelters and help to finance them.
- Al-Anon/Alateen institutions\* or limited-access groups may hold meetings at such a facility.

### **Sharing Facilities**

In some localities, Al-Anon may not be able to support its own answering service or Al-Anon Information Service (Intergroup). If it is necessary to share space with another enterprise, using Al-Anon letterhead and renting a private post office box, for example, will prevent any appearance of affiliation.

### **Clubhouses**

#### **Operated by A.A. Members**

Many groups use meeting facilities provided and operated by A.A. members. In keeping with our Seventh Tradition, the Al-Anon and Alateen groups pay an agreed sum for rent and are maintained as separate entities at all times.

---

\* see also *Introductory Meetings*

## **Operated by Al-Anon Members**

Members, as individuals, may establish and operate clubhouses where Al-Anon and Alateen meetings are held. In keeping with Tradition Six, a clubhouse is not owned, operated, financed or endorsed by an Al-Anon group, district, Al-Anon Information Service (Intergroup) office or Al-Anon Family Group Headquarters, Inc. It is suggested that Al-Anon and Alateen groups meeting at such facilities be self-supporting and function as separate entities.

## **Restrictive Policies**

Should any clubhouse policy be so restrictive as to exclude any Al-Anon member or include terms for the use of the facility that are contrary to Al-Anon/Alateen Traditions and principles, another meeting place may be more suitable.

## ***Members' Outside Involvement***

- When Al-Anon members serve on alcoholism boards or councils they do so as individuals, not as spokespersons for Al-Anon. Al-Anon membership may be disclosed to the board or council provided that anonymity is maintained at the level of press, radio, TV, and films, in accordance with Tradition Eleven.
- Al-Anon members who engage in legislation or support outside issues are free to do so as individuals. However, Tradition Ten suggests that the Al-Anon Family Groups have no opinion on outside issues. Thus, individuals do not discuss any such legislation or issues at meetings.
- Since Tradition Eight states that Al-Anon Twelfth Step work should remain forever nonprofessional, individuals who are professionals do not use their titles in conjunction with the Al-Anon name.

## **Commercial Enterprises**

### ***Filmmakers***

Some private filmmakers have indicated interest in producing films concerning Al-Anon and Alateen to sell to public agencies. In the interest of worldwide unity, it is recommended that prospective filmmakers be asked to write to the WSO to explain the proposed project and its probable audience. No commitments should be made to such producers by either groups or individuals. The Al-Anon name may not appear among the film's credits even though technical assistance has been provided.

## **Magazines**

Mail for Al-Anon/Alateen should not be directed to a post office box obtained by a publishing company—e.g., in a magazine printing an article about the fellowship. Members cooperating with the author of such an article should encourage the inclusion of an Al-Anon address for responses. For magazines with national coverage, the appropriate national address or P.O. box should be used.

## **Religion/Philosophies**

### **Meetings**

Al-Anon is a spiritual program; thus the discussion of specific religious beliefs at meetings may divert members from Al-Anon's primary purpose. Our meetings are open to all those who are affected by alcoholism whether the member has a religious belief or not.

### **Retreats**

#### **Al-Anon/Alateen Spiritual Meetings**

It has been suggested that the name "retreat" often has religious connotations and could imply affiliation if used in connection with an Al-Anon/Alateen event.

#### **Outside the Fellowship**

Al-Anon does not affiliate with other organizations; neither endorses nor opposes any other philosophies or spiritual programs. The Al-Anon/Alateen name, therefore, cannot properly be used to identify or publicize retreats or activities sponsored by others. This applies when most or even all of the participants are members of Al-Anon/Alateen. Otherwise there could be a misunderstanding of Al-Anon's purpose and function. In order to avoid any appearance of Al-Anon/Alateen affiliation, it is important to keep promotion of such events outside of Al-Anon/Alateen meetings and meeting locations. Our experience suggests that confusion arises when such events are announced in Area newsletters, Al-Anon/Alateen local bulletins and at group meetings.

#### **Within the Fellowship**

Area Newsletters or local Al-Anon/Alateen bulletins should not be used as a means of promoting or announcing retreats of any kind to the Al-Anon/Alateen membership, nor should retreats be promoted before, during, or after Al-Anon/Alateen meetings by use of leaflets or announcements.



## **Conventions**

Religious services and announcements of them are not a part of an Al-Anon/Alateen event.

## **Dilution of the Al-Anon Program**

### ***Outside Therapies***

Our Al-Anon experience helps us understand we are powerless over another person's drinking. This makes us aware at a meeting of the danger of being diverted from our own recovery by techniques that are focused on the recovery of the alcoholic.

Further, the Sixth Tradition suggests that there be no promotion or endorsement of any outside therapies. At an Al-Anon/Alateen meeting, in keeping with the Al-Anon/Alateen focus, the groups do not announce or discuss activities of other anonymous Twelve Step programs. Al-Anon/Alateen Area newsletters and local bulletins may publicize activities of Al-Anon/Alateen groups and those A.A. activities with Al-Anon participation. Publicizing other organizations' activities creates an appearance of affiliation.

### ***Labels***

Focus on the Al-Anon interpretation of our program is strengthened when we avoid using professional terms and labels since they may confuse members by implying affiliation with certain persons or specific therapies.

### ***Professional Involvement***

Professionals may initiate the formation of an Al-Anon/Alateen group provided that the meetings are *then* conducted by Al-Anon/Alateen members. Professionals who are not Al-Anon members may want to invite an existing Al-Anon or Alateen group to provide a brief on-site meeting to demonstrate how group meetings function.

### ***Drugs/Narcotics/Prescription Medications***

A symptom of alcoholism in the home may be the abuse of drugs by family members. Occasional discussion of this topic is acceptable at an Al-Anon or Alateen meeting as it may be one of the results of living with alcoholism. However, our responsibility is to ensure Al-Anon's survival as a resource for families and friends of alcoholics. By focusing on these drug-related problems, we risk

being diverted from Al-Anon's primary aim. Referral to appropriate sources of help may be suggested to those in need.

### ***Families with Related Problems***

Many individuals come to Al-Anon seeking help. If these individuals determine they have not been affected by a problem drinker, they may be informed of our Third Tradition, which states in part, "the only requirement for membership is that there be a problem of alcoholism in a relative or friend." They may also be informed of other sources of help.

the appearance of a conflict of interest and safeguards Al-Anon's singleness of purpose. Accordingly, Al-Anon's policy is that members who are also members of A.A. do not serve as Group Representative (GR), District Representative (DR), Area Delegate, World Service Conference member, alternate to any of these service positions, or on any committee of the World Service Office.

Filling service positions is a matter of district and Area autonomy, within this policy and the spiritual principles that form its basis. Tradition Four grants autonomy to local service arms, except in matters affecting Al-Anon or A.A. as a whole. Al-Anon members who are also members of A.A. participate fully in all group activities, including group conscience decisions. However, they do not hold Al-Anon service positions that vote in matters affecting another group or Al-Anon or A.A. as a whole.

Participating in Al-Anon service is integral to recovery for every member. Step Twelve, carrying our message to others, is a very important part of Al-Anon service. Members of Al-Anon who are also members of A.A. are often in a position to carry our message to those who are not aware of the benefits of attending Al-Anon Family Groups. Members of Al-Anon who are also members of A.A. may serve Al-Anon in ways that include being an Alateen Group Sponsor (see "Alateen Policy") or they may be invited by local/Area service arms, the Board of Trustees, or the World Service Office to participate in projects, in keeping with the spirit of this policy.

This policy on service participation by members of Al-Anon who are also A.A. members protects Al-Anon's viability as a program dedicated to helping the families and friends of alcoholics. It ensures that Al-Anon's service structure represents the unique perspective of families and friends of alcoholics, recognizing that the alcoholic's perspective is represented in A.A.'s service structure. Members honor this policy out of respect for Al-Anon unity and the group conscience process, in accordance with Tradition One and Tradition Two.

of anyone who is deceased. (Contact the WSO for details.)

The World Service Office accepts contributions in memory of deceased Al-Anon members from “family” who are not Al-Anon members. The Fellowship recognizes that accepting such contributions can give comfort to families as described in Tradition Five.

The World Service Conference defines “family” as anyone who has a close relationship of loving care and concern for another. The individual donor defines his or her relationship to the deceased Al-Anon member.

This one-time gift of gratitude is limited to an amount no greater than \$500. Memorial contributions by non-members are not solicited.

## **Notes and Updates**

## **Notes and Updates**

## **Notes and Updates**

# World Service Handbook

*The “World Service Handbook” explains how Al-Anon is held together worldwide, how it is structured, and how our trusted servants can best function within our structure.*

## Table of Contents

Introduction	131
Terms Used in Al-Anon	131
World Service Office	135
What it Does	135
How It Is Structured	136
World Service Conference	139
Purposes	139
Historical Background	139
The Al-Anon-Alateen Relationship	141
Conference Structure	141
Composition of the Conference	142
Suggested Procedures	143
How It Works	143
Conference Agenda	144
How the Conference is Financed	145
Conference Procedures	146
Area Procedures for Joining the Conference	146
At the Group Level	146
At the District Level	148
At the Assembly Level	149
Election Assembly Procedure	149
At the Assembly: Preparation	149
Elections	150
Post-Election Activities	152
Finances	152
General Information for Assemblies	153
Duties of Assembly Members	155
Group Representative (GR)	155
District Representative (DR)	157
Temporary Chairman	158
Chairman	158
Secretary	159

*Note: Vertical lines in outer margins indicate where changes were made for this edition.*



Treasurer	159
World Service Delegate	160
World Service Delegate's Alternate	161
Area World Service Committee	162
Interim Assemblies	163
District Meetings	164
Chart: World Service Conference Structure	166

# Introduction

This is your “World Service Handbook.” It is for every member of our fellowship who has found the personal benefits and satisfactions that come from taking an active part in Al-Anon’s growth.

The opportunities to serve described here can take us far beyond the boundaries of the group and our personal problems. While our Ninth Tradition provides that Al-Anon, as such, shall remain unorganized, it does suggest that an orderly structure and logical procedures will make it possible for Al-Anon to carry its message with maximum effectiveness.

This “World Service Handbook” explains how Al-Anon is held together worldwide, how it is structured, how each member who is elected or appointed to a particular responsibility can best function in it.

Since our growth depends on how well we serve the fellowship, this book can be helpful as a guide. It gives the methods that have long been standard practice in service work worldwide. All these procedures have been drawn from trial-and-error experience and should be changed only when an Area Assembly is fully agreed that such changes will better adapt these guidelines to its needs.\*

The suggestions offered here differ in some details from those in earlier versions of the “World Service Handbook.” This came about because of the more comprehensive experience with the procedures that many groups shared with the committee entrusted with this revision.

## Terms Used in Al-Anon

*The term “Al-Anon” is always understood to include Alateen. To keep it simple, the pronoun “he” is used throughout.*

**Area Coordinator** An Al-Anon/Alateen member, not necessarily a Group Representative (GR), appointed by the World Service Delegate or Assembly Chairman, or elected or appointed according to Area autonomy. The Coordinator usually serves for a three-year term and votes at the Area World Service Committee meetings, but not at the Assembly unless he is a GR. An Area Coordinator unifies one of the Al-Anon special services for an Area (such as Alateen,

---

*\*If and when the Area Assembly is agreed on alterations in the procedures recommended, it is vital that all groups in the Area be informed of the changes and why they were necessary.*

Archives, *The Forum*, Group Records, Newsletter Editor, Literature, Public Outreach [Public Information, Cooperating with the Professional Community, and Institutions]).

**Area World Service Committee (AWSC)** This Committee consists of the officers of the Assembly, District Representatives, Coordinators, and liaison members, who meet between Assemblies to discuss Area and district matters, plan the agenda for the Assembly, initiate projects, and make recommendations to the Assembly. All Committee members may vote at the meetings of the Area World Service Committee.

**Assembly** A meeting of the Group Representatives (GRs) for the purpose of electing a Delegate to the annual World Service Conference, an Alternate Delegate, and Assembly officers. The Assembly also meets between elections to receive and distribute reports on Area and world service affairs. It reviews and approves interim reports of the Area World Service Committee. If a District Representative has not been previously elected by the GRs of a district, his election may take place at the Assembly. (See “Caucus.”)

**Assembly Area** A state, province, or territory represented at our World Service Conference by a Delegate. Some states and provinces that are populous have been divided into two Areas, each with its own Delegate. (See “Conference Structure” section.)

**Assembly Center** The city where the Assembly meets.

**Caucus** A meeting at the Assembly of GRs from a given district, convened for the purpose of electing a District Representative if none has been elected in his home district prior to the Assembly.

**Director of Business Services** An individual responsible for all financial aspects of the World Service Office (WSO) and with direct oversight of Business Services.

**Districts** Convenient segments into which an Area is divided by the Area World Service Committee, with the approval of the Assembly.

**District Meeting** A meeting of GRs held as necessary in a central location within a district to elect a District Representative, to hear his reports, and to discuss district matters.

**District Representative (DR)** An incoming, outgoing, or active past GR who is elected by the other GRs in his district either in his home district or at an Assembly. He assists the Delegate in passing

on information about World Service Office activities and Conference decisions to the GRs in his district. He is a member of the Area World Service Committee.

**Evolving National Structures** A network of Al-Anon groups (outside the World Service Conference Structure) in the process of developing a service structure.

**Executive Director** Chief Executive Officer of Al-Anon Family Group Headquarters, Inc., who has oversight responsibility for all functions of the World Service Office.

**General Service Office (GSO)** A service structure of one or more nations outside the World Service Conference Structure with a Board of Trustees and other elected Al-Anon members responsible for Al-Anon service-related activities in their respective structure.

**Group Representative (GR)** A member, preferably with a basic understanding of the Al-Anon program, who is elected, subject to the dual member policy, for a three-year term by his group (Al-Anon or Alateen). He attends Assembly and district meetings and acts as a contact between the group and the DR, and between the group and the Area World Service Committee.

**Liaison Member** A member appointed or elected by the local Al-Anon Information Service (Intergroup), which serves one or more districts. He provides a link between this service and the Area World Service Committee and encourages the exchange of information between the two. He usually serves for three years. He votes at the Area World Service Committee meetings, but not at the Assembly unless he is a GR.

**Panel** A panel consists of one-third of the Delegates attending the World Service Conference. A panel is elected every year for a three-year term. The elections of the three panels are staggered so that a Conference always includes one panel of Delegates with two years' experience. A non-panel Area is one that has not yet joined the Conference.

**Volunteer Selected Committees** Consist of Al-Anon/Alateen members with a broad understanding of our program who concentrate on one of the elements of our fellowship, such as Alateen or literature. (See "World Service Office, How It Is Structured" section and Concept Eleven.)

**World Services** Services rendered to groups all over the world by our World Service Office (WSO), also known as Al-Anon Family Group Headquarters, Inc., and by General Service Offices (GSOs) outside the World Service Conference Structure. These services are channeled through the Area World Service Committees and the General Service Committees in other countries. To keep communication open between the WSO and GSOs, an International Al-Anon General Services Meeting (IAGSM) has become part of our structure.

**World Service Office Administrative Staff** Paid employees of the World Service Office who coordinate activities and projects for the service functions of the department to which they are assigned. The Directors (with the exception of the Director of Business Services) and Associate Directors must be Al-Anon members and are voting members of the World Service Conference.

**World Service Conference (WSC)** Al-Anon's annual business meeting, attended by all World Service Delegates from the United States, Canada, their territorial areas, Bermuda, and Puerto Rico; representatives from overseas countries; members of the Board of Trustees and Executive Committee; chairmen of selected committees (other than *The Forum* Editorial Advisory Committee); and the WSO administrative staff and other office personnel. The Conference provides guidance to the WSO in service matters brought to its attention.

**World Service Delegate** A District Representative who has been elected World Service Delegate for a three-year term by the GRs at an Assembly. The World Service Delegate shares Area experience at three annual Conferences, which serve Al-Anon worldwide. He brings the views and the spirit of worldwide Al-Anon back to his Area.

**World Service Delegate's Alternate** A DR elected to work closely with the World Service Delegate, to participate in Area world service activities, and to replace the Delegate if the latter cannot fulfill his three-year term.

# World Service Office

Al-Anon Family Group Headquarters, Inc., better known to most members as the World Service Office or WSO, is the headquarters of the entire fellowship.

## What It Does

### ***The World Service Office***

- Acts as the clearinghouse worldwide for inquiries from those who need help or want information about Al-Anon and Alateen.
- Registers Lone Members, new groups, electronic meetings, Information Services, and Literature Distribution Centers; provides them with literature, information, and help.
- Advises the Delegates of the formation or disbanding of groups in their Areas.
- Maintains data of worldwide Al-Anon/Alateen groups and Lone Members.
- Guides Al-Anon's public outreach efforts worldwide.
- Generates cooperation between Al-Anon and the professional community.
- Prepares and distributes Conference Approved Literature.
- Publishes and distributes Al-Anon materials to individuals and groups throughout the world.
- Plans and coordinates the World Service Conference.
- Gives an annual report of its activities and those of the World Service Conference in a *Conference Summary*.
- Carries the Al-Anon message to institutions and encourages the formation of Institutions groups to help those affected by someone else's alcoholism.
- Strives to stimulate interest in service through TEAM events.
- Cooperates with A.A.'s General Service Office, located in New York City, in all matters affecting both fellowships.
- Guides countries outside the United States and Canada in developing their structures and establishing General Service Offices.
- Is responsible for services to Al-Anon Family Groups all over the world, directly or through the Al-Anon General Service Office of each country.

- Maintains translation review of Al-Anon/Alateen literature into foreign languages and supervises the legal aspects of its distribution.
- Plans, coordinates, and participates in the biennial International Al-Anon General Services Meeting (IAGSM).
- Reports its activities quarterly to the Board of Trustees and annually to the World Service Conference.
- Organizes and preserves historical Al-Anon/Alateen material worldwide, past and present.
- Maintains the WSO Public Outreach and Members' Web sites.

## How It Is Structured

The World Service Office is headed by an Executive Director with assistance provided by a staff of paid employees, volunteer Chairmen of selected committees, and other volunteers.

The Executive Director and the staff handle correspondence with all parts of the fellowship to make sure that current information is disseminated to those concerned. Bilingual secretaries and translators are employed to help with foreign language correspondence.

The Delegate member committees\* are Literature, Admissions/ Handbook, Conference Committee on Trustees, Group Services, and Public Outreach.

Other committees\* in alphabetical order are: Alateen Advisory, Archives Advisory, Canadian Public Outreach, Conference, Executive, Finance, Forum Editorial Advisory, International Coordination, Nominating, and Policy, Outreach to Professionals Advisory, and Regional Service Seminar (RSS). Guidelines for most committees, which list committee composition and responsibilities, are available from the WSO.

Ad hoc committees may be established for specific purposes when the need arises.

**The WSO Policy Committee** is composed of a Chairman, all members of the Board of Trustees, members of the Executive Committee, the Chairmen of all WSO selected committees (except the Conference Committee on Trustees), and the Conference members of the WSO administrative staff. It meets quarterly in advance of the meeting of the Board of Trustees.

---

*\*The entire WSO committee structure is under review. Text will be updated in the next printing.*

Its function is to consider problems or projects brought to its attention by any Al-Anon or Alateen member. Its statements of policy, based on our Traditions, are subject to the approval of the Board of Trustees and the World Service Conference. In particularly sensitive or debatable questions, the decision may be deferred until the Conference convenes.

**The Executive Committee** which meets each month, is the administrator of the World Service Office, with legal authority granted by the Board of Trustees to conduct its daily affairs. Its seven members, one of whom serves as Chairman, are appointed by the Trustees. They include the Executive Director, one member of the administrative staff, the Chairmen of the Policy and Finance Committees, and three Al-Anon members elected by the Board of Trustees who contribute experience in specific fields and situations.

**The Board of Trustees** is composed of seven to 21 volunteer members: one sustaining member (the Executive Director), Trustees at Large, and Regional Trustees. Our cofounders Lois W. and Anne B., now deceased, were honorary lifetime members. The term of office for Trustee at Large and Regional Trustee is three years; they may serve two terms, which may be consecutive. Trustee at Large candidates submit qualifying resumes to the WSO. Nominees are interviewed and selected by the full Board of Trustees. Each year, in January, the Board nominates three Trustees at Large.

Regional Trustee candidates submit qualifying resumes to, and are nominated by, their respective Areas. At the World Service Conference, the nominee is selected by members of the WSC Regional Nominating Committee composed of the Delegates from the region, Delegates chosen by lot from outside the region, and Board members chosen by lot.

The names of Regional Trustee and Trustee at Large nominees are presented to the Conference for an expression of traditional approval. All the nominees are then elected by the Board of Trustees at its annual meeting.\*

The Trustees, along with the members of the Executive Committee, direct the business operations of the World Service Office, observing the By-Laws of Al-Anon Family Group Headquarters, Inc. They are concerned with guarding the legal rights of the

---

*\*Revisions to the Regional Trustee Plan were approved at the 2010 World Service Conference. For details, contact the WSO. The "World Service Handbook" will be updated with the next printing.*



Al-Anon fellowship against those who may try to profit from our ever-growing public acceptance, with protecting our principles from distortion and dilution, and in general, with acting as the chief service arm of the World Service Conference. The Board serves as guardian of our Twelve Traditions, our Twelve Concepts of Service, and the Al-Anon World Service Conference Charter.

The purposes for which the corporation was formed, as set forth in its Certificate of Incorporation, are “to encourage, assist and serve the families and friends of alcoholics in dealing with the problems concerning and attendant on alcoholism; to reinforce their efforts to understand the alcoholic and to foster his or her restoration to normal life; to disseminate information in relation thereto and to conduct and participate in any other classes of service to assist families and friends of alcoholics in dealing with their problems.” To serve these purposes, it is the responsibility of the Trustees to review all operations of the World Service Office.

In managing the affairs of the corporation, the Board is authorized to:

- Establish and maintain the policies of the World Service Office.
- Control its property and finances.
- Make long-range plans.
- Authorize expenditures.
- Appoint the Executive Committee and other committees.
- Appoint an Executive Director and Director of Business Services for the World Service Office.
- Take whatever measures are prudent and effective in carrying out the purpose of our fellowship.
- Approve the final agenda for the World Service Conference.

Any Trustee who has a substantial financial interest in any contract or transaction requiring authorization by the Board may not vote on the matter.

Three-fourths of all authorized participants registered at the Conference may bring about a reorganization of the World Service Office if or when it is deemed essential. They may request the resignation of the entire Board of Trustees and nominate a new slate of Trustees. Prior to resignation, it is the responsibility of the outgoing Trustees to vote on the successor slate presented by the Conference. For the purpose of bringing about a reorganization of the World

Service Office, the number of World Service Office participants voting shall be limited to one-fourth of the total Conference vote.

In this instance, the final decision-making body is the World Service Conference. (Further details of the Board's composition, jurisdiction, and responsibilities will be found in Article 10 of the Al-Anon World Service Conference Charter.)

## World Service Conference

### Purposes

Al-Anon's Tradition Two states: "For our group purpose there is but one authority—a loving God as He may express Himself in our group conscience. Our leaders are but trusted servants—they do not govern."

The World Service Conference makes the group conscience available and effective for all Al-Anon. It is the practical means by which the group conscience can speak; it is the voice of world Al-Anon and the guarantee that our world services shall continue to carry on under all conditions.

The Conference protects Al-Anon and Alateen against a service breakdown; it makes for unity and enables our fellowship to act *as a whole* upon important matters. This makes it the principal guarantor of Al-Anon and Alateen's harmony and survival.

### Historical Background

From 1951, when Al-Anon began, until 1961, when the Conference was born, the world services for Al-Anon were conducted from the Clearing House office in New York. All the work was done by a group of volunteers and a few paid workers, all of them living in the New York area. In 1954, our services were incorporated as Al-Anon Family Group Headquarters, Inc., solely for business purposes. There was a Board of Directors that took care of the business and policy matters with the help of an Advisory Board.

When our fellowship was still small, this service arrangement worked well and did much to unify Al-Anon and spread its message around the world.

This meant, however, that Al-Anon services were not linked to our growing groups. There was no way for the services to share with and account to those they served. It was only by means of

mail polls and correspondence that the World Service Office was able to receive the guidance and direction of the whole Al-Anon membership.

This degree of isolation from the fellowship as a whole could have proved hazardous for our future. If an unauthorized decision proved to be a serious error, confidence in the World Service Office could be weakened; this would affect the whole vital service effort. Without direct linkage with the widespread Al-Anon groups, it might not have been possible to repair such a condition.

Al-Anon has followed A.A.'s path from the beginning, using its principles and adapting its service structure to our own needs. A.A. had found that the group conscience of its fellowship as a whole could best be heard through the establishment of a conference of delegates representing all sections of the continent and meeting yearly with the Board of Trustees and the General Service staff. A.A.'s first conference met in the spring of 1951.

From 1955 until 1962, Bill W. spent much time developing suitable principles and philosophies for the guidance of all A.A.'s services. These, he felt, should agree with the principles and philosophies expressed or implied in the Steps and Traditions and with A.A.'s experience. The resulting document is divided into two parts: "The A.A. Service Manual" and "Twelve Concepts for World Service."

By 1961, Al-Anon had agreed that its group conscience should have the same means of being guided in the performance of its services worldwide. A simple, inexpensive plan worked out by Bill and Lois W. was put into effect on a three-year trial basis.

When the Conference was first initiated, in order to obtain equal representation from all sections of the United States and Canada, the continent was divided into four quadrants by lines drawn through its approximate center from east to west and north to south, coinciding with state and provincial boundaries. Three Delegates were chosen in the first year from each of the four quadrants. These came from the states and provinces with the greatest number of Al-Anon groups. In each of the second and third years, 12 more Delegates were chosen from those states and provinces with the next greatest number of Al-Anon groups. Following this formula, all states and provinces have had the opportunity to join the Conference.

By 1963, the experiment had proved this linkage between the groups and headquarters so effective that the members of the trial Conference voted unanimously to make it permanent. With

A.A.'s Service Manual as a guide, our "World Service Handbook" was developed for Al-Anon by a Handbook Committee, chaired by Lois W. The Al-Anon World Service Conference Charter (see index), long in the process of development, was unanimously adopted by the 1967 Conference. This is a traditional, not a legal, framework within which the Conference functions.

In the meantime, in 1965, the name "Board of Directors" was changed to "Board of Trustees," and since the Conference itself now serves as an advisory board, the previous advisory board was dropped. An Executive Committee was established to aid the Board of Trustees in the conduct of administrative affairs.

## The Al-Anon–Alateen Relationship

Alateen is an integral part of our fellowship. Area World Service Committees are urged to encourage Alateen participation at district and Assembly levels.

An Alateen Group Representative (GR) has both voice and vote in the district and Area Assembly and may hold office (if elected by Al-Anon and Alateen GRs) at all world service levels: District Representative, Assembly officer, and Delegate.

## Conference Structure

The Al-Anon fellowship is represented annually at a World Service Conference (WSC). It is attended by one elected Delegate from each Assembly Area, the Board of Trustees, the Executive Committee, volunteer Chairmen, and the voting members of the World Service Office administrative staff. Representatives from non-panel Areas (those not yet electing a Delegate) and countries other than the United States and Canada may attend with voice but no vote.

The Group Representative (GR) is the first link in the chain that leads to the World Service Conference. Each GR is chosen by members of the group and may serve as GR in no more than one group at a time.

The District Representative (DR) is the next link. The Area is divided into districts, each with one DR, who is chosen by the GRs in his district to serve on the Area World Service Committee.

If a GR becomes a DR, he fulfills both functions unless the Area Assembly chooses to have its groups elect new GRs to replace those who have taken on the duties of DR.

If the DR does not continue to be his group's representative, he relinquishes his vote at the Assembly to his GR replacement. This follows the long-standing principle of one vote per group, which was reaffirmed by the 1975 World Service Conference and applies as well to officers of the Area World Service Committee. They retain their vote at the Assembly only if they have been re-elected GR.

The Delegate and new Assembly officers are elected by the GRs at an election Assembly, held prior to December 31 at a convenient location in the Area every three years. The Assembly is attended by all GRs in addition to members of the Area World Service Committee. Al-Anon members are encouraged to attend their Area Assemblies.

In Areas where terms of office begin on January 1, only the outgoing GRs vote for an incoming Delegate and officers—from among the outgoing DRs only. Under this procedure, the new GRs do not vote for the Delegate and officers with whom they will be working for the next three years.

However, an Assembly may prefer to have the incoming GRs elect the Delegate and officers. Under this method both the incoming and outgoing DRs are eligible to stand for office, provided they have previously served at the Area level.

Before the important decision is made as to whether the incoming or outgoing GR has the vote, all the elements of its particular situation should be carefully weighed by the Assembly.

Once the Delegate has been elected, he is no longer either a DR or a GR, so his group would elect a new GR, and his district would elect a new DR. The Delegate votes at Area World Service Committee meetings but not at the Assembly.

## **Composition of the Conference**

The World Service Conference (WSC) is composed of one elected Delegate from each Assembly Area, the Board of Trustees, the Executive Committee, volunteer Chairmen, and voting members of the World Service Office administrative staff. At the 1985 WSC it was voted to make the Conference member ratio two-thirds elected Delegates to one-third staff and volunteers.

A state, province, or territory having more than 400 groups may petition the Conference to divide and send an additional Delegate to the Conference (see Article 6. b. of the Al-Anon World Service Conference Charter). A state, province, or territory may divide only once, as reaffirmed at the 1982 World Service Conference.

A non-panel Area may ask the Conference for permission to send a representative to the Conference. Such representation is limited to two years, under the following stipulations:

- The representative's expenses are to be paid by the Area.
- The WSO is to be notified of his attendance no later than February 1.
- The representative is to have voice but no vote at the Conference. These conditions also apply to other countries, except that they may continue to send representatives indefinitely.

Unlike elected government officials, our Delegates do not represent local interests. They may reflect Area opinion and contribute Area ideas, but they are not bound by directives from their groups. The Delegates as well as all other Conference members are the trusted servants of worldwide Al-Anon.

## Suggested Procedures

While the procedures outlined in the "World Service Handbook" are suggestions, they have been found by Al-Anon/Alateen members who have followed them to be a simple and direct method of selecting Delegates for the Conference and for conducting Assembly and Conference affairs free of political friction.

Al-Anon experience suggests that we follow these procedures *before deciding on changes* and to make changes only when they clearly become necessary. Using the same structural plan makes it simple for all of us to understand each other's Assembly procedures. In addition, such uniformity does much to lessen the Conference workload at our World Service Office. The help of *every* Assembly is needed in forming the best possible framework and to make our future secure. However, if by majority agreement an Assembly decides to alter one or more of these guidelines, the changes should be a matter of record so all members of the Area Assembly can clearly understand them.

## How It Works

A majority vote of the Conference constitutes only a suggestion to the Board of Trustees and our WSO; a two-thirds vote is binding upon them, subject to the provisions of Concept Seven ("The Trustees have legal rights while the rights of the Conference are traditional").

On overall policy matters the Conference makes final decisions. The Board of Trustees and the World Service Office are service arms of the Conference, a part of the whole fellowship.

The Conference is empowered to pass resolutions, make recommendations to the WSO, direct committees to further study, or refuse to act at all in a given situation. It cannot, however, mandate or govern the Al-Anon fellowship, which it serves. The Conference represents the Al-Anon membership but does not rule it.

Prior to their first Conference, all newly elected Delegates are assigned to one of the WSO selected committees.

Upon arrival at the Conference, newly elected Delegates become acquainted with second- and third-year Delegates, as well as with members of the Board and staff. They are invited to visit their World Service Office.

The following are typical Conference activities:

- The Conference members are greeted by the Conference Chairman or Co-Chairman, who introduces the Chairman of the Board of Trustees.
- The Executive Director gives a summary of the year's work.
- The staff members and volunteer Chairmen of committees report on activities of the year.
- The Treasurer gives a detailed financial accounting, prepared by a certified public accountant, and presents a clear picture of our situation.
- The Conference discusses these reports and may name committees for further study if necessary.
- If such committees are appointed, they make recommendations and appropriate action is taken.
- Delegates report on Area matters.
- Other items on the agenda are taken up.

## Conference Agenda

The agenda is developed over the previous months by the Conference Committee. Suggestions of all Conference members and the membership-at-large are carefully considered.

A typical agenda might include:

- Any action proposed by the Trustees affecting Al-Anon as a whole, to be presented for Conference debate and approval.
- Deviations from Al-Anon Traditions affecting Al-Anon as a whole.

- Proposed amendments to the descriptive text of the Twelve Concepts of Service.
- Consideration of proposed new literature.
- Questions and decisions in the field of overall public outreach.
- State of voluntary contributions—how noncontributing groups can be better informed.
- Consideration of local problems, provided they do or may affect Al-Anon as a whole.
- Special requests for guidance from Trustees or members of our WSO.
- Workshops and town-hall type meetings on service functions; how returning Delegates can best serve their Areas.
- Matters concerning Conference procedure, structure, and function.

## How the Conference Is Financed

**General Conference Expenses.** The cost of the Conference, as well as that of other worldwide Al-Anon services, is covered by the WSO General Fund. It is the responsibility of the WSO to ask all members to respond generously to the four appeals sent annually (in February, May, August, and November) for support of these services. All members reap the benefits of the Conference.

The general Conference expenses include the salary of a staff administrator and his assistants to handle the daily affairs of the Conference while in session; the cost of holding the Conference sessions; the cost of WSO members' (volunteers and paid staff) attendance at the Conference; and the expenses involved in writing and editing the *Conference Summary*.

**Delegates' Equalized Expenses.** Because costs of travel to the World Service Conference (WSC) are different for each Delegate, a formula was developed to provide a fair equalization of expenses.

The Delegate's equalized cost is calculated by dividing the total estimated travel, hotel, meal, and incidental expenses for the Delegates, including their portion of the costs of the Conference Notebook, and printing and mailing of the *Conference Summary* to Area World Service Committee members by the number of Delegates. This cost is reported to the Board of Trustees. A substantial portion of this cost, as determined by the Board of Trustees, is the equalized expense and is paid by the Areas. The Conference Committee informs each Area that this amount is to be sent to the WSO by the



Area Treasurer before January 1. The Delegates' expenses are then defrayed by these funds, regardless of traveling distance.

Any Area may choose to contribute additional funds, up to and including the entire cost of sending a Delegate to the WSC.

## Conference Procedures

### Area Procedures for Joining the Conference

The Area must first submit a request for admission to the World Service Conference. The Admissions/Handbook Committee will review the request and will make a decision based on policies previously accepted by the Conference. If permission is granted, the Area may proceed as follows:

Our WSO suggests, as an Assembly center, the city with the largest number of groups. The most active registered group in this Assembly center is then invited to elect a temporary Chairman. (See "Duties of Assembly Members, Temporary Chairman" section.) The temporary Chairman notifies our WSO of his election.

The WSO sends each registered group in the Area the name and address of the temporary Chairman and a copy of this "World Service Handbook" for the GRs to study prior to the election Assembly.

Well in advance of the Assembly, the temporary Chairman calls a planning meeting of all groups in the Assembly center to

- Select a date and meeting place for the Area election Assembly. (If this designated Assembly center is not convenient, another site may be chosen for the election Assembly.)
- Notify all groups in the Area of the time and place of the Assembly where the election will be held to elect a DR from each district, Assembly officers, a Delegate to the annual World Service Conference, and an Alternate Delegate.

### At the Group Level

#### ***Election of a Group Representative (GR) and an Alternate***

The GR is elected by his group for a three-year term by any election procedure it chooses. An AI-Anon/Alateen member who is also a member of A.A. is not eligible to serve as GR. Since the newly elected GR may be attending the election Assembly, the group's elections should precede the date of the Assembly. To emphasize the need for selecting informed GRs, a special election meeting may

be called by the group, with time devoted to the role of the GR in our service structure and his work in the district and Area. A group may re-elect its GR for another term.

Since a GR may be unable to attend all district and Area meetings, an Alternate GR is needed and is elected at the same time. The Alternate may be runner-up in the elections. The Alternate GR's duties may include serving as the group's public outreach contact, newsletter reporter, and official greeter of newcomers and visitors.

If the GR resigns or proves to be inactive, the Alternate completes the term and may then be elected for a three-year term of his own. Another Alternate may then be elected. No one who is also an A.A. member may serve as Alternate GR.

In a city where there is an Al-Anon Information Service (Inter-group), the Alternate GR may serve as the Information Service Representative (ISR). The GR generally serves as the Alternate Information Service Representative (AISR).

### ***When the GR Has Been Elected***

He immediately sends his name and address to the Area Secretary or Group Records Coordinator, so he can be informed of the time and place of the next Assembly. In a new Area the GR informs the temporary Chairman.

The GR attends the Assembly, bringing this "World Service Handbook."

He makes himself thoroughly familiar with his duties. (See "Duties of Assembly Members" section.)

### ***Finances***

The Assembly appeals to each group in the Area for contributions to be sent to the Area Treasurer. The Treasurer sends the equalized expense amount to the WSO and reimburses the Delegate and Area committee for expenses in the Area and for all Assembly overhead.

Each group provides its GR with sufficient funds to fulfill the GR duties including participation in the Assembly. Expenses may include meals, transportation, accommodations, and registration fees. Overhead expenses of the Assembly and the cost of sending the Delegate to the World Service Conference are paid by the Assembly with contributions from the groups within the Assembly Area.

Each group supports the district in the purchase of public outreach materials and activities (e.g., literature displays, mailings of special announcements, rent for district meetings).

## At the District Level

### ***Election of a District Representative (DR) and Alternate***

The election of the DR and Alternate DR from among the incoming, outgoing, or active past GRs (see next paragraph), none of whom are members of A.A., takes place in the fall of the year after the election of GRs and before election of Area officers. This is often done at a district meeting, unless geographical distances make this impractical. In the latter case, the DR is elected by a caucus of GRs at the Assembly. This term of office is three years, coinciding with those of Area officers and Delegate. Each district may choose its own method of electing.

The DR who is completing his term calls the district election meeting and notifies each group of the meeting, inviting the incoming, outgoing, and active past GRs and others who wish to attend.

If the DR resigns, proves to be inactive in his district, or for any reason is unable to serve, the Alternate DR completes the term. If the GRs of a district are not aware of the DR's failure to attend Area World Service Committee meetings, the Area World Service Committee may request a replacement.

In a city where there is an Al-Anon Information Service (Inter-group), the Alternate DR may be a member of its service board. The DR generally serves as the Alternate Information Service board member.

Other duties of the Alternate DR may include serving as Treasurer or Secretary of the district, as public outreach contact from the district to the Area, or as chairman of meetings on the service structure, Traditions, and Concepts.

### ***When the DR Has Been Elected***

He notifies the Area Secretary or Group Records Coordinator of his election and that of his Alternate. He acquaints himself thoroughly with the duties of a DR. (See "Duties of Assembly Members" section.)

### ***Finances***

The DR's expenses to attend Assemblies and Area World Service Committee meetings are shared by the groups within the district. When the DR is also a GR, the Assembly expenses are normally paid by the group he represents. Money for this purpose may also be raised by special events such as district workshops, potluck sup-

pers, rummage sales, and other cooperative ventures. The DR's expenses may be paid directly from such funds or may be reimbursed by the Area Treasurer.

## **At the Assembly Level**

### ***The Election Assembly***

This is held once every three years before the end of December. The Area World Service Committee may also schedule interim Assemblies, which are called by the Chairman at such other times as it is deemed necessary. One such Assembly could be held to hear the Delegate's post-Conference report. Some Delegates prefer to give their reports at combined district meetings arranged by two or more DRs.

**Preparing for Election Assemblies.** Before the Assembly is to convene, the Chairman (or temporary Chairman) prepares for the meeting by making sure

- Al-Anon/Alateen members who are not GRs are invited to attend the Assembly to serve as tellers.
- A book is provided in which each GR is to register, giving his name, address, and group name.
- A map of the Area, with district boundaries indicated, is hung in the Assembly room.
- A chalkboard is at hand.
- Pencils and slips of paper are available for the voting.
- All GRs have this "World Service Handbook."

## **Election Assembly Procedure**

If and when the Area Assembly is agreed on alterations in the procedures recommended, it is vital that all groups in the Area be informed of the changes and why they were necessary.

### **At the Assembly: Preparation**

The Chairman (see "Duties of Assembly Members" section):

1. Calls the meeting to order. (If this is the Area's first Assembly, the temporary Chairman conducts the meeting, but only until a three-year Chairman is elected.)
2. Asks for a moment of silence followed by the Serenity Prayer.

3. Reviews the procedure in this “World Service Handbook” or any other preferred method for the election of the District Representative, the Delegate, and an Alternate. It is important that everyone also understands the method agreed upon for the election of Area officers.
4. Asks for a vote of acceptance of the proposed method of election. Years of experience have shown the method described in this “World Service Handbook” to be fair and trouble-free. If another method is considered, it should be clearly understood and agreed upon by a two-thirds vote of the Assembly. In keeping with the principle of one vote per group, the Chairman has a vote only if he is still a GR.

## Elections

### ***Election of District Representative (DR)***

In many Areas, it is practical to elect DRs in their home districts prior to the election Assembly. Where this is not possible, the election takes place at the Assembly.

### ***The Chairman***

- Points out on the Area map the division of the Area into districts. If questions arise about the division or number of districts, the Chairman asks for discussion and a vote on changes of district boundaries. An advantage of dividing into smaller districts is that they can be covered more conveniently by the DRs.
- Asks the GRs from each district that has not yet elected a DR to gather in groups to caucus. If the caucus is small, only informal discussion and agreement may be needed. Otherwise, written ballots should be cast and the same procedure followed as for electing Area officers. A DR may repeat his term, provided that the GRs in his district re-elect him.

### ***Election of World Service Delegate\****

The Chairman asks the GRs who have the right to vote to elect a Delegate who is not also a member of A.A.\* A Delegate may not succeed himself, but may be re-elected after an interim three-year

---

*\*At the 1977 World Service Conference, it was voted that our policy is clearly defined, that Al-Anon/Alateens holding dual membership are not eligible for the office of Group Representative; therefore, the Admissions/Handbook Committee of the Conference would refuse admission of a Delegate who holds dual membership in Al-Anon/Alateen and A.A.*

term provided he has remained active in service at the Area level. Each group has one vote.

1. The Chairman asks each DR and others eligible, if any, whether he is prepared to serve as Delegate for three years. If so, he becomes a candidate.
2. Names of all candidates for the post of Delegate are listed on the board by the Secretary.
3. The Secretary calls the roll of voting members.
4. Paper and pencils are distributed for written ballots.
5. Non-voting members are selected to serve as tellers, collectors of ballots, and to record and tally votes on the board.
6. Written ballots are cast, collected, and given to the tellers to count.
7. Votes will be written on the board alongside the names of the candidates.
8. The first candidate to receive a two-thirds vote is elected.
9. If no one has the required two-thirds vote after several ballots have been taken and if two candidates each have 40 percent or more of the total vote, the Chairman may suggest that the two candidates stay and the others withdraw.
10. Whether or not any names are withdrawn, another ballot is taken.
11. If still no election occurs, the Chairman asks for a motion to close the balloting and that the choice be made by lot between the two high candidates. The first one drawn becomes the Delegate. Instead of this, many Assemblies prefer to have a final ballot taken. Then the candidate with the most votes becomes the Delegate.

### ***Election of Alternate Delegate***

The Chairman then calls for the election of a World Service Delegate's Alternate who is not also a member of A.A., following the same procedure as for Delegate.

In case the Delegate cannot complete his three-year term, the Alternate automatically becomes the Delegate for the balance of the Delegate's term. Another Alternate should be elected as soon as possible from among the DRs and officers. Since a Delegate should never be long without the assistance of an Alternate, the Delegate who has taken over may ask the Chairman to appoint an interim Alternate until a special meeting of the Assembly can be called.

When a DR becomes Delegate, he is no longer a DR and his district elects a new DR. He has a vote at the Area World Service Committee but not at the Assembly, as this would mean more than one vote per group.

### ***Election of Officers***

The Chairman then calls for the election of Assembly officers, usually the Chairman, Secretary, and Treasurer, from among DRs. Each officer serves for a three-year term. He asks tellers to pass ballots to all GRs and to place all DRs' names on the board.

1. GRs vote for a Chairman by written ballot. In addition to the DRs, the outgoing Delegate may be included on the slate for this office. If the Delegate is elected Chairman, he has no vote at the Assembly.
2. Tellers count ballots and check the names on the board.
3. Balloting continues until one name receives a majority of the votes. This elects the new Chairman.
4. A Secretary and a Treasurer are elected from among the DRs by the same method.
5. Assembly officers, including the Alternate Delegate, may continue to serve as DRs.
6. If a vacancy occurs among the Assembly officers between meetings or an officer is unable to attend meetings, another DR may be appointed by the Chairman to replace the officer until another can be elected. The Assembly Area should never be long without a full quota of officers.

### **Post-Election Activities**

The Chairman directs the Secretary to send a report of the election Assembly to the Associate Director of Member Services—Conference at the WSO with a duplicate to the newly elected Secretary, giving names and addresses of the Delegate, the Alternate, officers, DRs, and Area Coordinators.

### **Finances**

The Chairman then introduces the matter of financing. He explains that Delegates' expenses to and from the World Service Conference are equalized so that each Area pays the same amount. The portion of the Delegates' expenses not covered by the equalized expense contributions is paid by the WSO.

Delegates' interim expenses include telephone, postage, and the cost of visiting the groups in the Area. These will be met from the Area treasury. Finally, there will be the overhead expenses of the Assembly, rent, newsletter, incidental expenses, and others incurred by the Area World Service Committee.

The Chairman then presents a budget developed by the Area World Service Committee for the approval of the Assembly. The anticipated expense will be shared by each group in the Area. The GRs attending the Assembly should come prepared to discuss, approve, and act upon methods of raising funds.

The Chairman directs the Assembly Treasurer to collect these funds and to issue receipts to the GRs so the GRs can account for the outlay to their respective group Treasurers. The Assembly Treasurer disburses the collected funds to the appropriate people.

Absent GRs should be asked to have their groups' share of costs remitted to the Assembly Treasurer.

If GRs are not prepared for the full outlay, the Chairman asks that group donations for the Delegate's expenses be sent to the Treasurer by December 1.

A check to cover equalized expenses for the Delegate is sent by the Assembly Treasurer to the Associate Director of Member Services—Conference at the WSO before January 1.

By March 1, the Associate Director of Member Services—Conference at the WSO sends each Delegate a check for transportation and incidental expenses. This amount may be more or less than the equalized amount sent by the Assembly Treasurer.

If there is no other business, the Assembly is then adjourned.

## **General Information for Assemblies**

1. Upon receiving the results of an election, our World Service Office sends a letter of welcome to each new Delegate, with the date of the next Conference.
2. The Delegate, not the Alternate, receives all communications from our WSO, even if the Delegate was not able to attend the Conference.
3. The Chairman, elected for a three-year term, calls and conducts all subsequent Assemblies and Area committee meetings.



4. A full Assembly is comprised of the Delegate, officers, DRs, and GRs.
5. Assemblies are usually held at regularly scheduled intervals. The Area Al-Anon and Alateen groups are notified of each Assembly by the Chairman through the Secretary, the Area newsletter, or by any other effective method.
6. If the Alternate Delegate resigns, a new Alternate should be elected as soon as possible. If lack of time before the date of the Conference makes this impossible, and the Delegate has also resigned, the Chairman may attend the Conference in the Delegate's place. If the Chairman is unable to attend, next in line would be a past Delegate, beginning with the most recent one.
7. If an officer resigns or for any reason is unable to serve, a DR may be appointed by the Chairman to replace the officer until another can be elected to complete the term. He may then be elected for a three-year term of his own. In case the Delegate resigns, the Alternate finishes the Delegate's term and then may be elected for a three-year term as Delegate.
8. After the Delegate's third Conference, an Assembly is called to elect a Delegate and officers whose terms begin the following January 1.
9. Some Areas may elect the outgoing Delegate as Chairman of the Assembly. Where this occurs, he does not vote. Other Areas use the Delegate's Conference experience by electing or appointing him an Area Coordinator of a special service (e.g., Alateen, Archives, *The Forum*, Literature, Public Outreach [Public Information, Cooperating with the Professional Community, and Institutions]).
10. The Area World Service Committee meets whenever need arises to develop the Assembly agenda and to discuss Area affairs.
11. In Areas that have not as yet formed districts, the Delegate and officers are elected from among the GRs.
12. A DR who has resigned to take a current Assembly assignment (e.g., Newsletter Editor, Assembly officer, or Coordinator of a special service) may stand for the office of Delegate.
13. In order to draw on experience gained in service, an Area may choose to permit anyone who has served a three-year term as DR, has remained active at their Area level (as Newsletter

- Editor, Coordinator, etc.), and regularly attends Al-Anon meetings to stand for the office of Delegate.
14. One may hold an Assembly office in only one Assembly Area at a time.

## Duties of Assembly Members

### Group Representative (GR)

A GR is a vital link in the continuing function, growth, and unity of world Al-Anon. He is a member elected by his group for a three-year term. He attends Assemblies, maintains contact between the group and the district and between the group and the Area World Service Committee. He should also make himself thoroughly familiar with the *Al-Anon/Alateen Service Manual* (“World Service Handbook,” “Al-Anon and Alateen Groups at Work,” “Al-Anon’s Twelve Concepts of Service,” and the “Digest of Al-Anon and Alateen Policies”).

GRs should be members with experience, stability, and an understanding of the Traditions and how they work, as applied in the “Digest of Al-Anon and Alateen Policies.” It can be a challenging job. Ample time is needed for GRs to perform their many duties.

If a group also has an Alternate GR, the following duties may be shared:

- ◆ **The GR and World Service**

Through the contacts he makes with other GRs and the Area World Service Committee, the GR can gain knowledge of Al-Anon world service and the purpose and work of the Conference. This will enable him to explain these to the group. The GR should be allowed regular time at group meetings to convey information concerning Al-Anon world service affairs.

- ◆ **The GR and District Meetings**

The GR attends all meetings of his district.

- ◆ **The GR and the Area Assembly**

In addition to attending the election Assembly, the GR is expected to attend all scheduled Assemblies (and any interim Assembly the Chairman or Delegate considers necessary) and to report back to the group. The GR or

Alternate GR, in the GR's absence, votes at the Assembly. Each group has one vote.

- **Mailing Address at the WSO**

The GR has the responsibility of seeing that mail from the World Service Office is reaching his group. If mail is not being brought to meetings by the person who is listed as the Current Mailing Address (CMA), the GR consults first with the CMA and, if a change is warranted, contacts the District Representative and the WSO to provide an up-to-date CMA (possibly his own), a telephone listing, and other pertinent group information. If the group has a PO Box, or if for any other reason the GR is not the group's CMA, all mail should be referred to him. Although he does not replace the group Secretary, he can explain communications in light of his understanding of the world Al-Anon picture.

- **The GR and *The Forum***

The GR is also *The Forum* representative. He encourages the group to subscribe for at least one copy, acquaints members with its value, and urges them to subscribe. He also suggests stories of interest be sent to *The Forum* at the WSO.

- **The GR as Pipeline**

Communicating at district meetings, the GR can bring his group's viewpoint on any situation or problem concerning Al-Anon to the attention of the DR. In turn, he informs his group of the outcome of the meetings.

- **The World Service Delegate's Report**

If the DR or the Delegate cannot personally give the Conference report to the group, the GR may do so and explain the functions and purpose of the Area Assembly and the Conference.

- **Public Outreach (Public Information, Cooperating with the Professional Community, and Institutions)**

Local public outreach activities in the immediate community may be spearheaded by the GR, who may recommend forming a committee within the district, using material available from our WSO. If there is an Information Service, public outreach work affecting all

the groups within its area of activity may be its responsibility. Liaison and cooperation should be maintained between the Information Service, the districts, and the Area Public Outreach (Public Information, Cooperating with the Professional Community, and Institutions) Coordinators.\*

## **Finances**

The GR should be mindful of Al-Anon and Alateen's traditional insistence on being self-supporting. He makes sure the appeals for support of the WSO, sent four times a year (February, May, August, and November), are read to the group. He may personally present to his group the appeals sent by the Area Treasurer for support of the Assembly and give the group Treasurer the name and address of the Area Treasurer.

- **Conference Approved Literature (CAL)**

The GR, recognizing the importance of CAL, makes sure that the pamphlet *Why Conference Approved Literature?* (P-35) is always available at the meeting. He encourages use of a variety of CAL for meeting topics.

## **District Representative (DR)**

The DR is elected from among the incoming, outgoing, or active past GRs in his home district prior to the Assembly or by caucus at the Assembly. Each DR represents one district within the Area. He helps the groups in his district understand their relationship and responsibility to the worldwide fellowship.

### **The duties of the DR are**

- To call and chair district meetings at regular intervals.
- To help the Delegate in every way possible in disseminating Conference information and reports.
- To keep in touch with the GRs of his district to learn the views of the groups and their problems, which, in turn, he may report to the Area World Service Committee or the Delegate.
- To visit all the groups in his district, particularly new groups, to make sure they are getting necessary information and help.
- To help the groups understand and apply the Traditions, which guide us in our fellowship activities.

---

\* When the World Service Office structure changed in 2002, some Areas chose a combination of these Coordinators and named them Public Outreach.

- To prepare and update a mailing list of the GRs in his district for the Area World Service Committee.
- To urge every group to complete and promptly return the group data sheets sent out annually by the World Service Office.
- To check the group's Current Mailing Address (CMA) with each GR in the district to determine if it is correct.
- To make sure mail from the WSO is reaching the groups and being shared with the members.
- To attend Area World Service Committee meetings and report to the Area World Service Committee on activities within his district.
- To notify the Area World Service Committee and WSO of groups that have disbanded.

## Temporary Chairman

This office is necessary only in an Area preparing for its first Assembly. The temporary Chairman immediately notifies the WSO of his election. He sees that the time and place for a pre-Assembly meeting are chosen and that all groups in the Assembly center are invited to help with the planning. He chairs this meeting, where all preparations for the election Assembly are made, including notifying all groups in the Area. He serves as Chairman of the Assembly until a full-term Chairman is elected; the latter then takes over the balance of the meeting.

## Chairman

A Chairman should have leadership and organizational ability, serving rather than dictating. It is essential to be able to plan an agenda and conduct meetings in an orderly manner. Communication and cooperation with others are key elements of good chairmanship.

- The Chairman conducts all Assemblies and Area World Service Committee meetings during his three-year term of office.
- He asks the Secretary to send out notices of all meetings to the Delegate, the Alternate, Area officers, and all voting members.
- If any officer other than the Delegate resigns before the end of his term, the Chairman appoints another DR to fill the office temporarily. As soon as convenient, an Assembly should

be called to elect a successor for the unexpired term. If the Chairman resigns, the Area World Service Committee names a Chairman pro tem or the Delegate may serve as Chairman until an election can be held.

- The Chairman, after consulting with the Delegate, calls an Assembly soon after the Delegate's return from the Conference to hear the report of WSC proceedings and decisions. He may also call an Assembly at other times deemed necessary by the Delegate or the Area World Service Committee.
- He calls meetings of the Area World Service Committee, preferably at regular intervals, to discuss Area matters.
- Before the end of the Delegate's three-year term of office and allowing ample time for a new Delegate to take office by the first of January, the Chairman calls the Assembly for the election of a Delegate and other officers.

## Secretary

- The Secretary or Group Records Coordinator compiles a complete mailing list of all GRs, DRs, officers, and Coordinators and keeps it up-to-date.
- He sends out all notices of Assembly and Area World Service Committee meetings. He attends to all regular secretarial work and takes minutes of all meetings. These should be sent to the Area World Service Committee members soon after the meeting and be recorded in a permanent minutes book to be passed along to his successor.
- At election Assemblies, he calls the roll of all voting members and lists on the board candidates for office.
- He sends to the Associate Director of Member Services—Conference at the WSO the names and addresses of the Area World Service Committee members.

## Treasurer

- The Treasurer handles all Assembly collections and funds.
- At least once a year he prepares a special appeal letter to be sent to all groups asking them to contribute to the Area treasury to cover Assembly expenses, including contributions to the Delegates' equalized expense.
- He forwards to the WSO, before January 1, the Delegates' equalized expense amount.

- He issues receipts to GRs for any contributions they make on behalf of their groups for the Assembly.
- He pays all bills for expenditures approved by the Area World Service Committee. It is a sound business practice to have four members authorized to sign checks; of these, two signatures should be required on every check.
- He makes quarterly written financial reports to the Area World Service Committee and periodic reports to the Assembly.

## World Service Delegate

The Delegate is a channel through which information flows. The conscience of Al-Anon can work effectively only if it is informed. Much depends on the Delegate being thoroughly familiar with the *Service Manual* throughout his term of service.

- He brings to the Conference the viewpoint of his Area on matters affecting the entire fellowship and returns to his Area with a broader perspective of Al-Anon worldwide.
- He is the bridge of understanding that links the groups in his Area with world Al-Anon/Alateen to help them continue to function in unity.
- He is the servant of Al-Anon as a whole.

### At the Conference

- The Delegate attends all sessions of the Conference so that he may consider carefully the issues brought up, vote intelligently on them, and thus help to guide the Trustees in making their decisions.
- He tries to get a clear and comprehensive picture of our world fellowship to bring back to his home groups.
- He learns facts and figures; even more important, he gains a vision of a great movement in action.
- He learns what our World Service Office has meant to Al-Anon/Alateen in the past and what it, with the guidance of the Conference, will mean to the future welfare of the fellowship.
- In order to broaden the scope of certain selected committees at the WSO, Delegates are appointed to them as members-in-the-field. They are kept informed of interim committee meetings at the WSO. They can only attend special meetings

of these committees at the Conference. They may later be consulted, by correspondence, on any related matter.

- He brings issues of concern to him to the attention of the Conference either through the Conference Committee or directly from the floor in open Conference session.

### ***In His Area***

- The Delegate gives his Conference report to the Area World Service Committee and GRs to carry back to their groups. As often as possible, he makes his report in person at group or district meetings; nothing is more impressive than an eyewitness account.
- He meets with the Area World Service Committee often to learn and evaluate the groups' reaction to his report and to hear their ideas on other pertinent matters. He can thus be better prepared to present his Area's views at the next Conference.
- If between Conferences the WSO needs overall group opinion on some urgent matter, the Delegate can get a cross-section of his groups' ideas through his DRs and GRs and report his findings. Thus, through the guidance of the Delegates, it becomes possible for the WSO to take any necessary action during the year.
- He may serve as a contact for public inquiries within his Area if the Coordinator is unavailable.
- The Delegate sends to the Associate Director of Member Services—Conference items to be considered for the Conference agenda.
- The Delegate submits to the WSO, no later than August 15 of the regional election year, either the Regional Trustee (RT) resume or notification that the Area does not have a candidate.

### **World Service Delegate's Alternate**

The Alternate Delegate works along with the Delegate as much as possible in communicating with the groups. He acquaints himself with all the Delegate's duties, so that if the Delegate is unable to finish his three-year term, the Alternate can step in to complete it.



If the Alternate must complete the term, a temporary Alternate is at once appointed by the Chairman from among the DRs to act until a special Assembly can be called to elect a new Alternate.

Many Areas have assigned or appointed the Alternate Delegate to serve as one or more of the following:

- Area Newsletter Editor
- Forum Coordinator
- Group Records Coordinator
- Chairman of Area convention planning committee
- Chairman of Area Budget Committee
- Alternate Area Chairman

The Alternate Delegate can also provide valuable service to the Area by:

- Visiting Area groups and districts
- Assisting Area committees
- Developing Alateen groups, encouraging Al-Anon members to sponsor them, and setting up Alateen workshops
- Other responsibilities as assigned by the Area

## **Area World Service Committee**

The primary function of the Area World Service Committee is to plan for the general improvement of both the Assembly and the groups. Voting members of this committee are usually the officers of the Assembly, the DRs, Coordinators of services (such as Alateen, Archives, Public Outreach [Public Information, Cooperating with the Professional Community, and Institutions], Literature, Group Records, Forum, or Newsletter), and liaison members from any Information Services (Intergroups). The Chairman of Al-Anon/Alateen activities at an A.A. area convention or Chairman of Area Al-Anon and Alateen conventions should also participate in Area World Service Committee meetings.

These meetings, called and chaired by the Area Chairman, may be held at stated intervals to hear and discuss the Delegate's report, to consider Area matters, to suggest items of interest for the Area newsletter, all with the purpose of informing and unifying the groups in the Area. To equalize travel expenses, successive meetings may be held in various localities within the Area.

Throughout the year, the Area World Service Committee is responsible for submitting questions that cannot be resolved at the district or Assembly level to the WSO. It also plans the Assembly agendas, prepares the Area budget, and studies the need for alternatives to these “World Service Handbook” suggestions and presents its findings to the Area Assembly.

When advisable, the Area World Service Committee suggests revisions of boundaries of existing districts to be approved at the Area Assembly.

When Al-Anon and Alateen groups are to participate in an A.A. or Al-Anon convention, a separate convention planning committee may be formed, using the talents of the membership as a whole. To assure liaison with the convention planning committee, a convention Chairman may be appointed or elected by the Area World Service Committee. He is responsible to the Area and submits reports to the Area Chairman.

All Al-Anon/Alateen members, except those who are also members of A.A., are eligible to serve as an Area Coordinator. Guidelines for Area Coordinators are available from the WSO or on the WSO Members’ Web site.

## Interim Assemblies

The purpose of the interim Assembly is to assure adequate interchange of information and ideas about service activities, not only in the immediate Area, but where worldwide Al-Anon is concerned. (A typical election Assembly was previously outlined in this “World Service Handbook”).

Topics the agenda might include are:

- Approval of Assembly minutes
- Chairman’s report on Area World Service Committee since previous Assembly
- Delegate’s report on Conference and/or recent communications from WSO
- Secretary’s report
- Treasurer’s report
- District reports from DRs on progress and problems
- GR time for ideas, opinions, and questions
- Application of the Twelve Traditions of Al-Anon

- Interpretation of the Twelve Concepts of Service
- Workshops—intensive discussion in small groups
- Town-hall meeting led by panel with all GRs participating
- Films and videos (for a list of current available films contact the WSO)
- Report on Area newsletter
- Reports from Coordinators of special services: Alateen, Archives, Public Outreach (Public Information, Cooperating with the Professional Community, and Institutions), *The Forum*, Literature, Group Records
- Reports from any other committees, such as Al-Anon Information Service (Intergroup), convention
- Brief information session on WSO service—conducted by the Delegate

## District Meetings

Various types of meetings may be held within a district to unite and inform local groups: meetings to hear progress reports of the Area World Service Committee, sharing sessions for discussion of district matters, round-robins or social evenings. At regular intervals, meetings scheduled and chaired by the DR are held to talk over such matters as:

- The need for local service committees such as Alateen, Public Outreach (Public Information, Cooperating with the Professional Community, and Institutions), a telephone answering service, or an Information Service. (Attention should be called to the respective Guidelines available from WSO.)
- Ways to familiarize groups, Information Services, and local service committees in the vicinity with Conference Approved Literature (CAL), with emphasis on specialized items available for teenagers, parents, men, and public outreach.
- Sharing with the fellowship worldwide by submitting articles or items of general interest to *The Forum*.
- Encouraging members to subscribe to *The Forum*, either singly or through bulk group orders. (When a group pays for multiple subscriptions, a small profit is realized on the sale of single copies at meetings.)

- The value of “Inside Al-Anon” as a sharing vehicle from the WSO to the groups.
  - Raising money to support a telephone answering service or expand an existing one.
  - Means of stimulating contributions from the groups in the district to Al-Anon’s World Service Office. (Our WSO informs the Delegate of all contributions from the groups in his Area; this information can be relayed by each DR so that GRs will know whether their groups have contributed.)
  - Problems that arise when Al-Anon Traditions are disregarded or other concerns that groups and committees have presented for consideration.
  - Workshops on Alateen, Public Outreach (Public Information, Cooperating with the Professional Community, and Institutions), Literature, or any other Al-Anon service.
- Collections at district meetings are a practical way to raise money.

# WORLD SERVICE CONFERENCE STRUCTURE

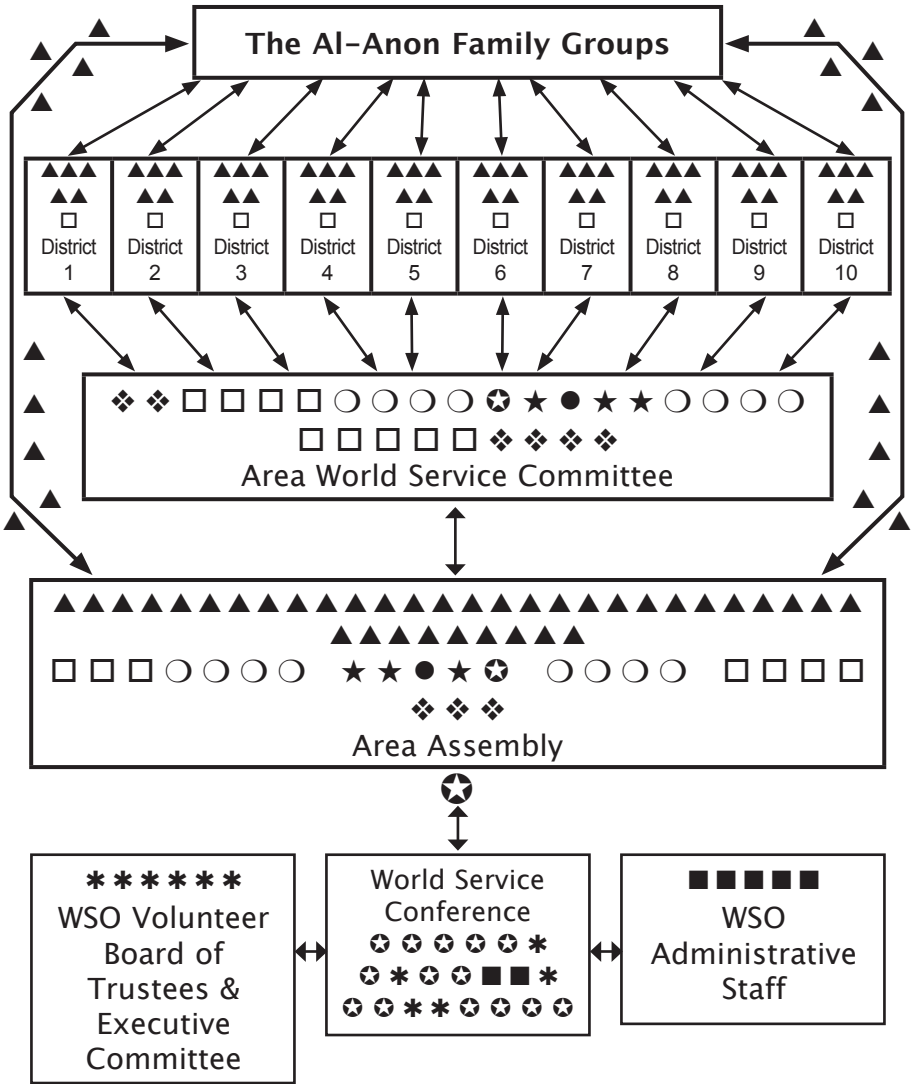

- ▲ Group Representative
- District Representative
- ★ Assembly Officer
- Chairman
- ⊕ Delegate
- Area Coordinator
- ❖ Al-Anon Information Service Liaison

The Area World Service Committee may also include Coordinators of special services such as Alateen, Archives, Public Outreach (PI, CPC, and Institutions), Newsletter Editors, The Forum, etc., and liaison members (from local Information Service centers or Intergroups)

## **Notes and Updates**

## **Notes and Updates**

## **Notes and Updates**



## **Notes and Updates**

# Al-Anon World Service Conference Charter

*The Al-Anon World Service Conference Charter is a body of principles and relationships through which Al-Anon as a whole can function. The provisions of the document are not legal, but traditional, since the Conference is not incorporated. This charter is an informal agreement between all Al-Anon and its World Service Office. Certain countries of the world, for language or geographic considerations, have established or may desire to establish their own General Service Office and national conference. This World Service Conference is now the senior conference.*

# Al-Anon World Service Conference Charter

As amended by the 2009 WSC

## Introduction

- a. The Al-Anon World Service Conference Charter is a body of principles and relationships through which Al-Anon as a whole can function. The provisions of the document are not legal, but traditional, since the Conference is not incorporated. This charter is an informal agreement between all Al-Anon and its World Service Office. Certain countries of the world, for language or geographic considerations, have established or may desire to establish their own General Service Office and national conference. This World Service Conference is now the senior conference.

## Charter

### 1. Purpose

- a. To be the guardian of both Al-Anon's world services and its Twelve Traditions;
- b. To be a service body, not a government.

### 2. Composition

- a. State, provincial and territorial Delegates from the United States and Canada and WSO members, the last including the Board of Trustees of Al-Anon Family Group Headquarters, Inc., the WSO Policy Committee, Executive Committee, and Administrative Staff;
- b. Representatives from other countries, when these countries as well as the Conference may be ready for their participation;
- c. Representatives from non-panel Areas within the United States and Canada.

### 3. Relation to Al-Anon

- a. The Conference acts for Al-Anon in the perpetuation and guidance of its WSO services.

- b. The Conference is a vehicle by which Al-Anon can express its views on policy and note deviations from Traditions.
- c. Delegates are free to vote as their conscience dictates and not necessarily as instructed by their Areas.
- d. No changes are to be made in the Al-Anon or Alateen Traditions, the Steps, the Concepts of Service (except the descriptive text), or the General Warranties of the Conference Charter (Item 12) without written consent of three-quarters of the Al-Anon Family Groups.
- e. Wording in the Charter may be changed by the vote of three-quarters of the Conference members; however, the protections afforded the Al-Anon and Alateen Traditions, the Steps, the Concepts of Service, and the General Warranties in item 3-d may not be taken away or lessened by Conference vote.

#### **4. Relation to the World Service Office**

- a. Two-thirds vote of Conference members in attendance is binding upon trustees and any related corporate service.
- b. The above does not affect legal obligations of the WSO in conducting business.
- c. In accordance with the provisions of the By-Laws of Al-Anon Family Group Headquarters, Inc., three-quarters of all members registered at the Conference may bring about a reorganization of the WSO if or when it is deemed essential and may request the resignation of the whole Board and nominate a new slate of Trustees. For this purpose only, the number of WSO members voting shall be limited to one-quarter of the total Conference vote.

#### **5. State and Provincial Assemblies: Purpose of**

- a. Assemblies convene at least every three years and as often in between as is deemed necessary for the purpose of electing District Representatives (if not elected in their own districts), Assembly officers, a Delegate to the WSC, and an Alternate.
- b. Assemblies are concerned primarily with world service affairs of Al-Anon.

#### **6. Assemblies: Composition of**

- a. In each state and province, elected representatives of all Al-Anon groups desiring participation meet together in a central location.

- b. States and provinces with large Al-Anon populations may petition the Conference to divide and send an additional delegate to the Conference, as provided for in the “World Service Handbook” for Al-Anon and Alateen groups.

## **7. Assemblies: Preferred Method of Election**

- a. District Representatives are elected from Group Representatives by written ballot.
- b. Delegates are chosen from District Representatives by a two-thirds written ballot or by lot.
- c. Alternates are elected at the same time and for the same term of office.
- d. It is strongly advised that the term of office of the Chairperson, other Assembly officers and District Representatives follow the same pattern.

## **8. Panels and Delegates’ Terms of Office**

A third of the Delegates, called a panel, are elected every three years for a three-year term. The election of each of the three panels is held on each of three consecutive years. This staggered election and tenure of office is provided so that a Conference shall always include a panel of Delegates with two years’ experience. (This method was adopted because some A.A.s found that their two-year plan resulted in too fast a turnover and the valuable experience of two-year Delegates was lost to the Conference.)

## **9. Conference Meetings**

The Conference meets annually. In grave emergency, special meetings may be called. Conference members may also be asked by the WSO to render advisory opinions at any time by mail or telephone poll.

## **10. Board of Trustees: Composition, Jurisdiction, Responsibilities**

- a. The Board of Trustees of Al-Anon Family Group Headquarters, Inc. is composed of qualified members of Al-Anon groups. The Board elects its own successors, with nominees subject to the approval of the Conference or a committee thereof.
- b. The Board is the chief service arm of the Conference, which is guardian of Al-Anon’s Twelve Traditions. Subject to *e*, below,

the Board has responsibility to determine policy and manage the business affairs of the WSO. It may appoint suitable committees and elect members to its Executive Committee.

- c. If any subsidiary services are later formed, the Board of Trustees will be primarily responsible for their policy and financial integrity.
- d. The By-Laws of Al-Anon Family Group Headquarters, Inc., and any amendments thereto are subject to recall by the Conference by a two-thirds vote of all its members. All By-Law amendments will be presented to the first Conference to be held after their adoption by the Board of Trustees.
- e. Except in great emergency the Board of Trustees ought never take action liable to affect Al-Anon as a whole greatly without consulting the Conference. However, it is understood that the Board shall reserve the right to decide which of its decisions may require referral to the Conference.

## 11. Conference Procedure

- a. The Conference hears financial and policy reports of the Board of Trustees and WSO services.
- b. Delegates and WSO members take under advisement all matters affecting Al-Anon as a whole, engage in debate, appoint necessary committees and pass suitable motions for the direction of the Board of Trustees and the WSO.
- c. The Conference may recommend action respecting serious deviation from Al-Anon Traditions and Concepts of Service.
- d. The Conference may adopt procedures and elect any needed officers by a method of its choosing.
- e. A quorum shall consist of two-thirds of the members registered at the Conference.
- f. At the close of each yearly session, the Conference will send a full report of its proceedings to all World Service Conference members, past WSC members and Area World Service Committees (Area officers, Coordinators and District Representatives).

## 12. General Warranties of the Conference

In all proceedings the World Service Conference of Al-Anon shall observe the spirit of the Traditions: that only sufficient operating funds, including an ample reserve, be its prudent financial

principle; that no Conference member shall be placed in unqualified authority over other members; that all decisions be reached by discussion, vote and, whenever possible, by unanimity; that no Conference action ever be personally punitive or an incitement to public controversy; that though the Conference serves Al-Anon it shall never perform any act of government; and that like the fellowship of Al-Anon Family Groups which it serves, it shall always remain democratic in thought and action.

**Note:** The term Al-Anon includes Alateen. Therefore, the above Charter applies to all registered groups, including Alateen.

## **Notes and Updates**



## **Notes and Updates**

## **Notes and Updates**

# Al-Anon's Twelve Concepts of Service

*“Al-Anon’s Twelve Concepts of Service” deals with the “why” of our service structure in such a way that the valuable experience of the past and the lessons drawn from that experience can never be forgotten or lost.*

## Table of Contents

History of the Concepts	179
Introduction	180
Concept One	181
Concept Two	183
Concept Three	185
Concept Four	188
Concept Five	190
Concept Six	193
Concept Seven	194
Concept Eight	196
Concept Nine	198
Concept Ten	203
Concept Eleven	207
Selected Committees	208
Executives	213
Staff Members	213
Concept Twelve	214
Warranty One	216
Warranty Two	219
Warranty Three	220
Warranty Four	221
Warranty Five	225

*Note: Vertical lines in outer margins indicate where changes were made for this edition.*

# History of the Concepts

After A.A.'s General Service Office was established, Bill W. spent several years developing suitable principles and philosophies for its guidance that would coincide with the principles and philosophies of the Steps and Traditions and with A.A. experience. These are called A.A.'s Third Legacy.

Although Al-Anon is a distinct entity, our fellowship has its roots in Alcoholics Anonymous. Through our own Al-Anon experience, however, we have recognized the need for using A.A.'s three sets of principles or Legacies: the Steps, the Traditions, and now, the Concepts.

A poll of the one hundred or so groups in existence in 1951 led to the adoption of the Twelve Steps as a way of life for Al-Anon members. Later, the groups accepted an adaptation of A.A.'s Twelve Traditions as a framework within which to operate.

In 1968, the Al-Anon Conference unanimously approved the idea of Al-Anon developing its own Concepts of Service.

Then in 1969, the Conference Delegates were given copies of a tentative document worked out by a committee of in-townners and out-of-townners, chaired by Lois W., portraying service Concepts that coincided with Al-Anon experience and structure. A selection of knowledgeable Al-Anon members were also sent copies. During the year, both Delegates and longtime members sent in their suggestions.

Thus, the Concepts were well considered and revised before the Conference of 1970 affirmed them as guidelines for our services.

One theme welds the three Legacies together—Pass Along Understanding:

1. Recovery—The Twelve Steps urge the individual to carry the message to others.
2. Unity—The Traditions protect the groups from distracting or disrupting influences, so they can be free to pass along the Al-Anon word.
3. Service—The Concepts show how Twelfth Step work can be done on a broad scale; how members of a World Service Office can relate to each other and to the groups to spread Al-Anon's message across the world; and how a Conference of Delegates from all parts of the United States and Canada can supervise such a World Service, so it will always conform

to the Traditions. The 1984 Conference voted that the Twelve Concepts are to be accorded the same stature as the Twelve Steps and Twelve Traditions.

## Introduction

The Al-Anon Concepts of Service record the “why” of our service structure in such a way that the valuable experience of the past and the lessons drawn from that experience can never be forgotten or lost.

Each new generation of world servants quite rightly will be eager to make operational improvements. Unforeseen flaws in the present structure will perhaps show up in time. New service needs and problems will arise that may make structural changes necessary. These contingencies should be squarely met, and suitable alterations effected.

When structural change does seem advisable, its advocates need only present a strong case for such a change to both the Trustees and the World Service Conference for consideration. This is no more than would be required for the transaction and passage of any other piece of Al-Anon business.

For an appropriate period, any far-reaching structural change should be labeled a “trial,” and such changes, as well as lesser ones, shall on final approval be entered in the body of this *Manual*. The original text will be set out in an appendix, leaving the original draft of the Twelve Concepts as a record of former experience.

Change does not necessarily spell progress. Innovations may produce little more than a painful repetition of earlier mistakes. These Concepts, it is hoped, will forestall such repetition by holding the experience of the past clearly before us. If a mistaken departure is nevertheless made, they provide a ready means of safe return to an operating balance that otherwise might take years of floundering to rediscover.

The Concepts include a number of principles that have become traditional to our services but that have never been clearly defined and put into writing. For example: *Right of Decision* gives our service leaders proper discretion and latitude. The *Right of Participation* gives each world servant voting status commensurate with the member's responsibility and guarantees that each service board and committee will always possess the elements and talents that ensure effective functioning. The *Right of Appeal* protects and encourages minority opinion. The *Right of Petition* makes certain that griev-

ances will be heard and properly acted upon. These general principles can, of course, be used to good effect throughout our entire structure locally, nationally, and internationally.

The Concepts also delineate those important traditions, customs, relationships, and legal arrangements that weld the Board of Trustees into working harmony with the Executive Committee and staff and the selected committees of the World Service Office.

Great emphasis is placed on the need for a high order of personal leadership, careful induction methods for all incoming personnel, and the best possible relations among those who work in our services. The Concepts portray a structure in which all may labor to good effect with minimum possibility of friction. This is accomplished by a fair and balanced relationship of our workers to their work and to one another.

In service organizations, there is generally a choice between authoritarian structure, in which one person or group of persons has unqualified authority, and the democratic, which calls for checks and balances. It is human nature to try to enhance one's own authority and prestige when in the saddle. But when someone else holds the reins, we tend to resist heavy-handed management. Many of us can recognize these traits in ourselves.

The Concepts define working relations that can be friendly yet efficient. They especially restrain a tendency to concentrate on money and power, this being an underlying, though not always conscious, motivation.

It is hoped that these Twelve Concepts will be a welcome document for the use of our Trustees, the World Service Office, and the members of the Conference, and that the document will prove to be a reliable working guide in years to come.

## Concept One

***The ultimate responsibility and authority for AI-Anon world services belongs to the AI-Anon groups.***

Tradition Two declares, "For our group purpose there is but one authority—a loving God as He may express Himself in our group conscience. Our leaders are but trusted servants; they do not govern." This clearly implies that the groups are to be the final authority, that our leaders are to be entrusted with delegated responsibilities only.

The Al-Anon groups today hold the ultimate responsibility and authority for our world services, those special elements of overall service activity that make it possible for our fellowship to function as a whole.

Our first move toward the creation of a service structure for Al-Anon was the formation, in 1951, of a central office or Clearing House, as it was then called. This Clearing House was designed to initiate and maintain those special services for Al-Anon as a whole that could not be performed by single groups or Areas. This included writing uniform literature, developing a sound public relations policy, and handling large numbers of pleas for help. We hoped to encourage and aid new groups to form, and to furnish them with counsel based upon experience of older and already successful groups. We thought there might be a need for a monthly magazine, and perhaps later, for translations of our literature into other languages.

If Annie S., A.A. Doctor Bob's wife, had lived until 1951, she would undoubtedly have given great moral support to the efforts to open a service office. Her death in Akron, Ohio, in 1949 was a great loss to us all, for Annie had carried the message to many an alcoholic's relative. A.A. families in Akron consulted her constantly, and whenever she visited A.A. groups with Doctor Bob, she always told the wives how she had adopted the A.A. principles as a way of life for herself and urged them to do likewise. A number of Al-Anon groups were started in this manner. Wives of early A.A.s traveled from group to group and talked about their experiences and needs.

When Bill W. was trying to inspire the formation of an A.A. conference of delegates in 1950 by visiting many groups throughout the United States and Canada, he ran across quite a few groups of wives of A.A.s who met for a variety of purposes. Upon his return, he mentioned that these groups needed a unifying center to which they could write for information and suggested that his wife, Lois, establish such an office.

Thereupon Lois and another Anne, Anne B., working in Lois' home in the suburbs, began by asking A.A. whether they had the names of any A.A. wives' groups. Surprisingly, there were 87 names of families and groups of wives who had asked A.A. for help. Lois and Anne wrote to them, and 50 registered immediately. As correspondence increased, the office was moved to New York City, where more help was available.

At its start, the Clearing House polled the groups on the major questions of name, purpose, and method of support for our fellowship, and the adoption of A.A.'s Twelve Steps and Twelve Traditions, slightly modified for Al-Anon's use.

In 1954, the Clearing House was incorporated as a nonprofit unit under the title Al-Anon Family Group Headquarters, Inc., directed by a Board of Trustees consisting of volunteer Al-Anon members.\*

By 1960, many of our dreams for world service had come true. In nine years, Al-Anon membership had jumped from 50 groups to nearly 1,500. Unity of purpose had pretty much replaced the early dissimilarity of groups. The basis for membership had broadened. Membership in many groups was 50 percent or more families of alcoholics who did not belong to A.A. and perhaps never would. National publicity had brought in hundreds of members who had no contact with Alcoholics Anonymous. Al-Anons were confidently united in their purpose of helping themselves in order to help others—and indirectly the alcoholic—and to do this through the use of the Twelve Steps and Twelve Traditions.

As Al-Anon entered its second decade, polling groups on important issues became impractical. The procedure was slow and cumbersome, and because many groups did not respond to letters, polls were ineffective and sometimes inaccurate. There were also constant questions of policy that could not be settled by a poll and on which wrong decisions might lead to disaster. The group conscience had to point a way on these matters.

In order to meet this need, the Al-Anon groups in 1960 voted for the formation of the Al-Anon World Service Conference.

## Concept Two

***The Al-Anon Family Groups have delegated complete administrative and operational authority to their Conference and its service arms.***

The many Al-Anon groups scattered all over the world hold in their hands the group conscience.

But it is evident that, in order to get effective action, the groups must delegate the actual operational authority to chosen service representatives who are empowered to speak and act for them. The group conscience of Al-Anon could not be heard unless prop-

---

\* For details of the structure of the World Service Office, see Concept Eleven.



erly chosen Conference members were fully trusted to speak for it in most world service matters. Hence the principle of delegated authority and responsibility to our trusted servants must be implicit from the top to the bottom of our active service structure.

Our World Service Office (WSO) had taken on a crucial meaning for Al-Anon's future. If this vital center were to collapse or bog down, our unity within—and the carrying of our message to innumerable potential members without—would suffer serious and perhaps irreparable damage. Were we ready to take the precautions A.A. had taken to guard against impairment and to establish a Conference of Al-Anon Delegates to whom our service headquarters would be accountable?

Many of us thought we were ready. Also we recognized that the average member, preoccupied with group life and personal Twelfth Step work, knew little if anything about Al-Anon's worldwide activities. Few Al-Anons realized how much their group membership and unity were due to the little-noticed activities of our headquarters office.

A few at headquarters felt this attitude showed a lack of faith in Al-Anon. They said: "Why change? Things are going fine. We poll the groups' opinion on any important question. Delegates from all over the country will mean expense and politics. We don't want either; let's keep it simple."

However, the decision lay with the groups. In 1960, Al-Anon held a meeting at the A.A. International Convention in Long Beach, California. There this matter was discussed. Al-Anons from all over the United States and Canada came to this convention. Their vote on the question would represent a cross-section of Al-Anon. Those present voted unanimously to set up an annual Conference of Delegates on a trial basis for three years. This action was later confirmed by a poll of the groups.

Some years after the Conference had become a permanent foundation for Al-Anon world services, we found that our fears had been largely groundless. Its success had exceeded our highest expectations. It proved that the Al-Anon groups can and will take the final responsibility for their world services.

Our World Service Conference (WSC) is the active voice and the effective group conscience of our society in world affairs.

We believe our fellowship is a spiritual society characterized by enough enlightenment, responsibility, and love for God and man to ensure that our democracy of world service will work under all condi-

tions. We rely confidently on Tradition Two, our group conscience, and our trusted servants. Hence it is with a sense of great security that we are assured that Al-Anon's WSC will use its vested authority for giving shape to the destiny that God is holding in store for us all.

## Concept Three

### ***The right of decision makes effective leadership possible.***

Within the framework of their general responsibilities, whether defined by charter, resolution, or custom, all world service boards, committees, and executives should decide which matters they may properly dispose of and on which they will report, consult, or ask specific directions. By tradition, our world servants should be trusted with these discretions, otherwise no effective leadership is possible. Let us consider why the Right of Decision is imperative for our leaders. Let us examine this principle in its practical application to all levels of our world service structure.

The Al-Anon World Service Conference (WSC) Charter and the Bylaws of Al-Anon Family Group Headquarters, Inc., define in broad terms the responsibility of the Conference to act on behalf of Al-Anon as a whole. In these two documents, a large area of delegated service authority and responsibility has been spelled out. These instruments describe the relationships between the groups, the WSC, the Trustees, and other service arms. These broad definitions and descriptions are an indispensable frame of reference; we could not function without them.

Nevertheless, it has long been evident that the Bylaws and the WSC Charter, important as they are, cannot by themselves ensure smooth functioning and proper leadership at the various levels of service. For example, knowing that they have the final authority, the groups may be tempted to instruct their Delegates exactly how to vote. There is no doubt that the Al-Anon groups have the right to do this. They can give directives to their Delegates on any and all Al-Anon matters.

But good management seldom means the full exercise of ultimate rights. Were the groups to carry their instruction of Delegates to extremes, we would be proceeding on the false premise that a group's opinion could be superior to Conference opinion. As a practical matter, this could almost never be the case. How could "instructed" Dele-

gates settle a question as well as WSC members acting freely with full facts to guide them? It is understood that complete reporting of WSC actions is always desirable. So is full consultation with District Representatives and Group Representatives. Nevertheless, the “instructed” Delegate who cannot act according to his own conscience on a final WSC vote would not be a “trusted servant” at all but a messenger.

The WSC Charter does not actually solve typical problems like these. It is a broad document that can be construed in various ways. Under one interpretation, the groups can instruct the Delegates as much as they like. Under another, the Delegates and Trustees can actually go counter to such instructions, *whenever new information gives them reason to change their point of view.*

Let us look at another illustration: In matters of policy, principles, and program procedures, the WSC has practically complete authority over the Board of Trustees consistent with the legal obligations of the individual Trustees and the Board as a whole respecting corporate business transactions. It surely would not be practical for the WSC to issue hasty and flat directives to the Board of Trustees on matters about which the Trustees would be far more knowledgeable than the Delegates.

Again, this same kind of confusion could beset the relations of the Board of Trustees to the Executive Committee and to committees directed by non-Trustee volunteers and paid service workers. The Board of Trustees certainly does have authority to control these entities; its authority is final. Yet if the Board of Trustees were to constantly exert their full and absolute authority and attempt to manage these operating entities in detail, then the volunteers and staff members would quickly become demoralized.

Therefore some traditional and practical principle must be applied that at all levels will continuously balance relations between ultimate authority and delegated responsibility. How shall we accomplish this?

The Al-Anon solution to these questions is found in Tradition Two, which refers to “trusted servants.” This provides that our responsible leaders be trusted to decide, within the framework of their duties, how to interpret and apply their authority and responsibility to each problem or situation as it arises. This sort of leadership discretion is the essence of the Right of Decision. We need have no misgivings about granting this privilege at every level of world service.

There will always be plenty of ultimate authority to correct inefficiency, ineffectiveness, or abuse. If the WSC does not function well, the groups are free to choose better Delegates to represent them. If the Board of Trustees gets badly out of line, the WSC can censure or reorganize the Board. If World Service Office (WSO) services should sour, the Board of Trustees can appoint a more effective Executive Committee and hire better help. These remedies are direct and adequate. But for so long as our world services function reasonably well, then “trust” must be our watchword, otherwise we shall wind up leaderless.

The above reasons show why our service bodies and members should have a traditional Right of Decision, which could be practically applied as follows:

- a. The WSC always should be able to decide which matters it will fully dispose of on its own responsibility and which questions it will refer to the Al-Anon groups or, more usually, to their Area World Service Committee or GRs. Therefore, it ought to be clearly understood and agreed that our WSC Delegates are primarily the world servants of Al-Anon as a whole. Only in a secondary sense do they represent their respective areas. Consequently they should, on final decisions, be entitled to cast their votes in the WSC according to the dictates of their own judgment and conscience.
- b. Similarly the Board of Trustees (operating of course within the provisions of its own Bylaws) should have the right, at all times, to decide when it will act fully on its own responsibility and when it will ask the Conference for guidance, approval of a recommendation, or actual direction.
- c. Within the scope of their defined or implied responsibilities, the WSO, its committees, staff, or executives should each have the right to decide when to act wholly on their own and when to refer a problem to the next higher authority.

This Right of Decision should never be used as an excuse for failing to render proper reports of all significant actions taken, for exceeding a clearly defined authority, or for repeatedly failing to consult those who are entitled to be consulted before an important decision or action is taken.

Our entire Al-Anon program rests squarely on the principle of mutual trust. We trust God, we trust Al-Anon, and we trust one another. Therefore we cannot do less than trust our leaders in ser-

vice. The Right of Decision we offer them is the practical means by which they may act and lead effectively; it also is the symbol of our implicit confidence.

## Concept Four

### ***Participation is the key to harmony.***

The Principle of Participation has been built into our whole service structure. If all authority were to be assigned to one group and virtually all responsibility to another, we would seriously handicap efficiency of operation and real harmony.

The Al-Anon World Service Conference (WSC) Charter specifically provides that the Board of Trustees of Al-Anon Family Group Headquarters, Inc. shall always be voting members of the WSC, as shall be the World Service Office (WSO) Policy Committee, Executive Committee, and members of the WSO administrative staff. As indicated in Concept Three, if the groups, sensing their great power, should try to overexercise that power by directing their Delegates how to vote at the WSC, those Delegates would feel they were neither participants nor trusted servants. If, in turn, the Delegates overexercise their power, they could make the Trustees mere rubber stamps.

Though it may seem inconsistent for service workers and Trustees to participate in voting on reports of their own activities, these reports constitute only a fraction of the business of the WSC, which is far more concerned with policies, plans, and actions to take effect in the future. The WSC needs the votes of such knowledgeable people as the Trustees and other members of the WSO.

Since our WSC, unlike governmental bodies, cannot be constantly in session, there is good reason not to give Delegates absolute voting authority over Trustees, staff members, and Committee Chairpersons. Delegates meet once a year for only a few days, and cannot have firsthand knowledge of many problems on which they are expected to vote. This is all the more reason for allowing the often better-informed minority of Trustees and WSO staff and volunteers the privilege of balloting.

Some Delegates may object that, on close votes in the WSC, the combined ballots of the Trustees and service workers may decide a particular question. But their greater familiarity through experience fully justifies this. It should also be noted that they are not likely to

vote in a bloc. Differences of opinion among them may be as sharp and considerable as those to be found among the Delegates.

The same concept is borne in mind when our Board of Trustees elects a Chairperson and members of the Executive Committee. If it wished, the Board could appoint its own members to most of these positions, but this is not done, because it would nullify the Principle of Participation.

The active management of the WSO, previously called the Headquarters Office, is vested in the Executive Committee, whose duty is to see that all projects are carefully carried out. Its seven members include the Executive Director, a member of the WSO administrative staff, the Chairpersons of the Policy and Finance Committees, and three qualified Al-Anon members. From time to time, others may be invited to attend Executive Committee meetings without vote.

Whenever the Chairperson of the Board of Trustees appoints a Chairperson to the selected committees, the same Principle of Participation is considered. Trustees or non-Trustee volunteers comprise these committees, which have staff administrators to do much of the detail work.

These arrangements permit a proper degree of voting participation. No class is set in absolute authority over another. Thus in the participatory method of doing business, there are no superiors and no inferiors, as distinguished from the institutional, military, or governmental method.

However, other than the Executive Director, no paid staff worker should become a Trustee. First, it would interfere with the rotation of the Board, which already has one nonrotating member. Second, if ever the Board of Trustees had to be reorganized by the WSC, paid Trustees in a bloc might prove a vested interest difficult to dislodge.

Our Board of Trustees may, however, invite paid staff members, accountants, and any others whose reports or advice may be required, to attend quarterly meetings of the Board, where they would have voice but no vote. When staff members are thus placed in direct communication with the Trustees, they realize they are wanted and needed.

Perhaps new generations of Delegates or Trustees may wish to weaken, modify, or eliminate the Principle of Participation. Occasionally a few Delegates may question the right of the Executive Committee, the staff, and even the Trustees to vote in the WSC. New volunteer members of the Executive Committee may ask why

any paid staff members should be on this business management committee. Every now and then a move may be made to abolish the Executive Committee as a separate entity so that the Board of Trustees could manage the office directly. But the Right of Participation in our service structure is of such high importance to our future that we are urged to preserve this traditional right in the face of every attempt to whittle it down.

Participation also responds to our spiritual needs. All of us deeply desire to belong. The Al-Anon ideal of a working partnership could never regard any member as second class. This is perhaps the main reason we have struggled to achieve participation at every level. The Right of Participation encourages us who serve Al-Anon to accept the necessary disciplines that our various tasks require. It assures us that we are truly the “trusted servants” described in Al-Anon’s Tradition Two.

## Concept Five

***The rights of appeal and petition protect minorities and insure that they be heard.***

The Rights of Appeal and Petition aim to protect and make the best possible use of minority feeling and opinion.

In the principle of the Right of Appeal, all minorities—whether among our staff, Executive Committee, selected committees, or Trustees—should be encouraged to file minority reports whenever they feel a majority to be in considerable error. When any minority considers an issue to be so grave that a mistaken decision could seriously affect Al-Anon as a whole, it has the actual duty of presenting a minority appeal to the body that made the decision.

This traditional Right of Appeal acknowledges that minorities can be right; that even when they are *partly* or wholly in error, they still perform a valuable service by asserting their Right of Appeal and compelling a thorough debate on important issues. The well-heard minority, therefore, is our chief protection against an uninformed, misinformed, hasty, or angry majority.

The traditional Right of Petition permits any person in our service structure including World Service Office (WSO) employees, members of the Executive Committee, selected committees, or Board of Trustees to petition for the redress of a personal grievance, carrying

the complaint, if desired, directly to the Board of Trustees. One should be able to do this without prejudice or fear of reprisal. However, the Board of Trustees has the right to delegate the consideration of any and all petitions to another body that it deems appropriate. Though in practice the right to petition the Board of Trustees will seldom be exercised, its very existence will tend to restrain those in authority from unjust use of power. Surely our workers cheerfully accept the direction and discipline that go with their jobs, but all should nevertheless be confident that they need not silently endure unnecessary and unfair personal domination. For all our paid workers at the WSO, the Board of Trustees has established a clearly defined process for the redress of a work related grievance. This process is outlined in the *Employee Policies and Procedures Manual of the World Service Office*.

It should be noted that while minorities, whether groups or individuals, have the right to be heard, it does not mean that the action in question will be delayed while the petition or appeal is being considered, nor does it guarantee that the decision will be overturned.

In our Al-Anon groups, individual freedom is of enormous importance. Anyone who feels his/her personal life is, or has been, deeply affected by close contact with a problem drinker is eligible for membership in Al-Anon. We never take away this right to belong. Neither do we compel our members to believe anything or pay anything.

In our world services, we also go to great lengths in our trust of minorities. Under Tradition Two, the *group conscience* is the final authority for Al-Anon world services. Nevertheless, the groups have recognized that for the purpose of world services our group conscience has certain limitations. It cannot act directly in many service matters, because it is seldom sufficiently informed about the problems at hand. During times of stress, it may not be the best possible guide, because emotional bias may prevent it, temporarily, from functioning efficiently or wisely. When, therefore, the group conscience cannot act directly, who does act for it?

We trust our servants, knowing that in the unusual event that they fail in their responsibilities, we still have ample opportunity to recall and replace them.

As trusted servants, our Al-Anon leaders must always be ready to do for the groups what the groups obviously cannot do for themselves. Consequently our servants are bound to use their own information and judgment, sometimes to the point of disagreeing with uninformed or biased group opinion.



The foregoing observations illustrate Al-Anon's concern for the freedom and protection of individual members and the whole membership's willingness to trust able and conscientious servants to function for us all.

Our WSC Charter is infused with provisions that ensure protection and respect for minorities. This is exemplified, for instance, in the method of selecting Delegates. Unless the majority candidate can poll a two-thirds vote of the Area Assembly, the names are placed in a hat with one or more of the choices of the Assembly minority. By thus drawing lots, the minority candidates have an equal chance with the majority's choice.

This method of electing Delegates strengthens the spirit of democracy among us. Unity is cemented, cooperation increased, and when the Delegate is finally chosen, the minority has no reason for discontent. To increase the actual spirit of democracy by special deference to minority opinion is better than to follow blindly the rule that insists in unqualified dominance by majority vote.

Consider another example: Our respect for the minority position plus a desire for unity and certainty often prompt the WSC to debate important questions of policy even in cases where a majority could easily be obtained. Such a voluntary practice is evidence of real prudence and courteous deference to the views of all. The WSC usually makes important decisions on no less than a two-thirds vote.

This same consideration for the minority position can be found in the WSC Charter provision that no Conference vote can be considered binding on the Board of Trustees unless it equals two-thirds of a Conference quorum. Up to this point, the Trustees have a power of veto. [See Concept Seven, legal rights of Board of Trustees.] They may ask for further debate to check any tendency to haste or emotionalism. They may choose to veto a simple majority or to act with it. Here again is recognition of the constructive value of a trusted minority.

By adding the traditional Rights of Appeal and Petition to minority privileges, we grant to all minorities, whether among our staff, Executive Committees, selected committees, or Trustees, the means of discharging their world service duties confidently, harmoniously, and well.

In Al-Anon, we believe the spirit of democracy in our fellowship and in our world service structure will always survive despite any countertendencies that may beset us.

We believe that we shall never be subjected to the tyranny of either majority or minority, provided we carefully define the relationship between them. We can then tread the path of world service in the spirit of our Twelve Steps, our Twelve Traditions, and our Twelve Concepts of Service.

## Concept Six

### ***The Conference acknowledges the primary administrative responsibility of the Trustees.***

Just as the Al-Anon groups can act decisively in world service affairs only by entrusting authority and responsibility to their World Service Conference (WSC), so must the WSC in turn entrust administrative authority to Al-Anon Family Group Headquarters, Inc. (AFG, Inc.), in order that its Trustees may act freely and effectively in the absence of the WSC.

For several important reasons, the Trustees must have freedom to act. Next to the WSC, Al-Anon's Board of Trustees should be our most influential group of world servants. We have to consider carefully the kind and degree of authority, responsibility, leadership, and legal status the Trustees must possess in order to function effectively in the years to come. We need to define the kinds of professional and financial skills that will be required for an effective Board of Trustees. Thus we ensure the Board's capability of future leadership.

We need to show how the Trustees ought to be related to the WSC and, in turn, to the Executive Committee and any other active service committees or corporations that may be needed in the future. In a general way these relations are indicated in our Al-Anon World Service Conference Charter (WSC Charter) and on preceding pages; however, there remains a need to interpret them in detail. These relations should never be frozen into a rigid pattern. However satisfactory and right our present arrangements are, the future may require changes that we do not yet envision. New conditions may require refinements or even considerable alterations. For this reason, our WSC Charter is capable of being amended by the WSC itself.

If later we do make changes that happen to work out poorly, the experience of the past will provide, in these articles, a point of safe return to tested procedure.

A careful review of the legal and traditional rights of the Board of Trustees indicates its administrative responsibilities. Its authority in this field is unquestionably great.

Why should our Trustees be given this wide latitude of judgment and action? The answer is that they are held responsible for all our service activities, as well as for Al-Anon's worldwide public relations. They are expected to spearhead the formulation of Al-Anon policy and its proper execution. They are the active guardians of our Twelve Traditions. The Trustees have ultimate responsibility for the preservation and prudent management of all Al-Anon's financial assets. They are accountable for the internal controls of funds received and the investment thereof. The wide range of their activities is further detailed under Concept Eleven.

While the Trustees must operate under the close observation, guidance, and sometimes the direction of the WSC, it is nevertheless true that only the Trustees can evaluate and handle most of the innumerable transactions involved in our World Service operation. In view of this great responsibility, they must be given a correspondingly large grant of authority and leadership with which to discharge it. It must be understood that the conduct of our World Services is primarily a matter of policy and business. While our objectives are spiritual, these aims can be achieved only by means of an effective business operation. Since our Trustees must function like the directors of any large business corporation, they must have ample authority to manage and conduct Al-Anon's business.

## Concept Seven

***The Trustees have legal rights while the rights of the Conference are traditional.***

At first this Concept may appear contradictory. Actually both the rights of the Trustees and the World Service Conference (WSC) work well together. On the one hand, we see a Board of Trustees invested with complete legal power over Al-Anon's funds and services; on the other hand, Al-Anon's WSC has such great responsibility for and authority over all aspects of Al-Anon's program and policies that in those areas it could give the Trustees directives and secure their compliance.

This means that the actual power of the WSC will nearly always be superior to the legal power of the Trustees since it flows from the powerful traditional influence of the Al-Anon World Service Conference Charter (WSC Charter) itself. It derives from the large majority of group-chosen Delegates in the WSC. And finally, in any extreme situation, it would rest upon the unquestioned right of the Delegates to deny Al-Anon Family Group Headquarters, Inc., the moneys with which to operate—those voluntary contributions of the Al-Anon groups themselves. Theoretically, the WSC is an advisory body; practically speaking, it has the ultimate rights and powers.

The Board of Trustees is not likely to contest the clear and sustained will of the WSC Delegates and the Al-Anon Areas they represent. If someday a crucial stalemate arose between the Delegates and the Trustees, the WSC, as the conscience of Al-Anon, would find itself in complete authority over the Al-Anon Family Group Headquarters, Inc, and its World Service arms.

Experience shows that this balance of powers between the Trustees and the WSC is thoroughly workable. This balance can be maintained indefinitely, because the one is protected by tradition and the other by law.

An interesting question often raised by new Trustees is whether they have a legal right to say no to something the WSC wants.

In certain corporate business areas, the Trustees certainly do have this legal authority; on the other hand, they are quite at liberty to accept, even seek, advice and recommended directions from the WSC or other qualified sources. Just as the WSC should avoid the overuse of its traditional authority, so should the Board of Trustees avoid overuse of its legal authority.

Clearly, then, our Board of Trustees does reserve a veto power over any WSC action; this is legally necessary and right in principle, even though the veto will seldom be used. At certain times, however, the Trustees' veto could be of important and constructive use.

Here are three typical examples in which it would be the duty of the Trustees to veto WSC action:

1. If, in a time of haste or heavy stress, the WSC should take an action or issue a directive to the Trustees in clear violation of the WSC Charter or of the Bylaws of AFG, Inc., or if the WSC were to pass any measure so ill-considered or so reckless as to seriously injure, in the judgment of the Trust-

ees, Al-Anon's public relations, or Al-Anon as a whole, the Board of Trustees would have the duty of asking for WSC reconsideration. In the event of a WSC refusal to reconsider, the Board of Trustees could then use the legal right to veto. If desirable, the Board could appeal the issue directly to the Al-Anon groups themselves.

2. Although traditionally the Trustees should never substantially exceed a WSC approved budget without consulting the WSC, they should feel entirely free to reduce this budget figure during any fiscal year, even though such an action might curtail or cancel plans or projects initiated and directed by the WSC itself.
3. If, by reason of unforeseen conditions, any particular plan, project, or directive of the WSC should become impractical, unworkable, or legally inadvisable during a fiscal year, the Trustees should, without prejudice, be able to use their right of veto and cancellation.

In the years ahead, the WSC should always bear in mind the actual rights, duties, responsibilities, and legal status of the Board of Trustees; the Trustees should constantly realize that the WSC is the real seat of ultimate service authority. Then we may be sure that neither will be seriously tempted to violate either the authority or responsibility of the other. In this way, grave issues can always be resolved by harmonious cooperation.

## Concept Eight

***The Board of Trustees delegates full authority for routine management of Al-Anon Headquarters to its executive committees.***

The Trustees of the Al-Anon Family Group Headquarters act in two major capacities: (a) in matters of policy and finance, they are the principal planners and are responsible for final decisions; (b) in routine operations, the Trustees delegate full authority to executive committees charged with the management of Headquarters.

To arrive at this Concept, experience has led us through the following stages of development:

From 1951 to 1954, when Al-Anon's Headquarters was still trying to feel its way, the workers at the then-named Clearing House were advised by a committee of representatives of neighboring

Al-Anon groups who met occasionally. After the incorporation of Headquarters late in 1954, its Board of Trustees administered the World Service Office. Seven to eleven in number, the Trustees were meeting monthly and appointed a large committee of volunteers to advise them. This Advisory Committee included all the Trustees and convened every three months. Any recommendations or resolutions proposed by the Advisory Committee had to be ratified by the Board of Trustees.

In 1957, the Advisory Committee was further formalized by a Charter and given a new name—the Advisory Board. It was the authorized custodian of overall Al-Anon policy and finance. In the Charter the hope was expressed that a permanent conference of Delegates from the various states and provinces would eventually take the place of the Advisory Board. The day-to-day administration of the office, however, was still in the hands of the Trustees.

After three years' trial, in 1964, the World Service Conference came into being as the permanent guardian of Al-Anon's Traditions and services, replacing the Advisory Board.

By this time, however, the business of Al-Anon's Headquarters had grown so large that it became unwieldy for the Board of Trustees to handle the routine administration of the office. Our Trustees realized they could no longer be concerned, as a body, with the endless details that arose daily, weekly, and monthly in the routine conduct of the World Service Office. They also realized the need to devote themselves to the more serious questions of policy, leadership, finance, group and public relations.

Therefore, the Board decided to assign its administrative function to a more constantly available seven-member Executive Committee, possessing the Board's full legal powers. This Executive Committee is composed of three Al-Anon members, preferably not Trustees, elected by the Board; the Executive Director; an Al-Anon member from the administrative staff of the World Service Office; and the Chairpersons of both the Finance and Policy Committees. The Chairperson of this Executive Committee is elected by the Board of Trustees.

This Committee considers all Project Proposals and Project Approvals from committees and staff that fall within budget and existing policy. If a project exceeds budget, it is directed to the Finance Committee. If it entails a change in policy, it is directed to the Policy Committee.

The Board thus became custodian and guarantor of good management of Al-Anon's World Service Office.  
*continued on page 226*

## Concept Nine

***Good personal leadership at all service levels is a necessity. In the field of world service the Board of Trustees assumes the primary leadership.***

No matter how carefully we design our service structure of principles and relationships, no matter how well we apportion authority and responsibility, the operating result of our structure can be no better than the personal performance of those who serve and make it work. Good leadership cannot function well in a poorly designed structure. Weak leadership can hardly function at all, even in the best of structures.

Good leadership can be here today and gone tomorrow. Furnishing our service structure with able and willing workers is a continuing activity. We must constantly find the right people for our many service tasks. Since our future effectiveness thus depends upon ever-new generations of leaders, it seems desirable that we now define what a good service leader should be; that we carefully indicate for each level of service (especially for our Board of Trustees) what special skills will be required; that we review our present methods of finding and choosing leadership.

First let's remember that our service structure depends on the dedication and ability of thousands of Group Representatives (GRs), District Representatives (DRs), and Delegates. These are the direct agents of the Al-Anon groups; these are the indispensable links between our fellowship and its World Service; these are the primary representatives of Al-Anon's group conscience.

When choosing GRs, Al-Anon groups should keep these facts in mind. It is only the GRs who, in district or Assembly meetings, can name DRs and finally name the Delegate. Hence, great care needs to be taken in choosing these representatives. Hit-or-miss methods should be avoided. Groups without GRs should be encouraged to elect them.

As the GRs meet in their Assemblies to name a Delegate, an even greater degree of care and dedication will be required. Personal

ambitions must be set aside, antagonisms and controversy forgotten. “Who are the best qualified people we can name?” should be the sole thought.

The Handbook or Third Legacy method of naming Delegates by a two-thirds vote or by lot greatly reduces political friction; it makes each Delegate feel that he or she is truly a world servant rather than merely the winner of a contest. Thus far, our Third Legacy methods have produced DRs and Delegates of a high level of dedication and competence. Our Area Assemblies need only to continue to act with care and in a selfless spirit.

Some members, still doubtful whether choice by lot is a good idea, feel that the best person does not always win. It must be pointed out that each time we have disregarded the two-thirds vote or lot in naming Delegates, there has been a sense of defeat and disturbance in the minority camp, which is not offset by naming the supposedly best person. Indeed the second-best person can often be as good a Delegate as the Assembly's first choice and may even be a better Delegate.

Let us now consider the specific personal qualities a World Service leader ought to have. The following slightly modified essay, “Leadership,” written by Bill W. for a 1959 issue of the *A.A. Grapevine*, applies equally well to Al-Anon.

No society can function well without able leadership at all levels, and we are no exception. However, we sometimes warp the traditional idea of “principles before personalities” to such a point that there would be no personality in leadership whatever. This would imply rather faceless automatons trying to please everybody.

At other times, we may demand that our leaders be people of the most sterling judgment, morals, and inspiration.

Real leadership, of course, has to function in between these entirely imaginary poles. In our fellowship certainly no leader is faceless, nor is any leader perfect. Fortunately we are blessed with any number of real leaders—those men and women whose dedication, stability, vision, and special skills make them capable of dealing with every possible assignment. We have only to seek these folks out and trust them to serve us.

A leader is a person who can put principles, plans, and policies into such dedicated and effective action that the



rest of us want to back him up and help him with his job. When a leader is a power-driver, we rebel; when he is just an order-taker and exercises no judgment of his own, he isn't a leader at all.

A good leader originates plans and policies for the improvement of our fellowship. In new and important matters, he nevertheless consults widely before making decisions. Good leadership knows that a fine plan or idea can come from anyone, anywhere. Consequently, good leadership often discards its own cherished plans for those that are better, giving credit to the source.

Good leadership never passes the buck. Once assured of sufficient backing, it freely makes decisions and puts them into action, provided of course that such actions be within the framework of its defined authority and responsibility. A "politico" is an individual who is forever trying to "get the people what they want." A statesman is an individual who can carefully discriminate when and *when not* to do this. He recognizes that even large majorities, when badly disturbed or uninformed, can be dead wrong. When such an occasion arises with vital matters at stake, it is the duty of leadership to take a stand against the storm, using its every ability of authority and persuasion to effect a change.

Nothing, however, can be more hampering to good leadership than opposition for opposition's sake alone. "Let's have it our way or no way at all" is often powered by visionless pride or a gripe. The opposition that casts its vote "no" without giving any real reasons won't do either. Leadership should always have good reasons and give them.

Then, too, a leader must realize that even very prideful or angry people can sometimes be right, when the calm and the more humble are quite mistaken.

Another qualification for leadership is "give and take," the ability to compromise cheerfully whenever it can cause a situation to progress in what appears to be the right direction. Compromise comes hard to many of us. Nevertheless, progress is nearly always characterized by a *series of improving compromises*. We cannot, however,

always compromise. Now and then, it is necessary to stick flat-footed to one's conviction. Careful discrimination and keen timing are required in all situations.

Leadership is often called upon to face heavy and sometimes long-continued criticism—an acid test. There are always constructive critics, our friends indeed. We ought never fail to give them a careful hearing. We should be willing to let them modify our opinions or change them completely. Often, too, we shall have to disagree and then stand fast without losing their friendship.

Then there are destructive critics. They power-drive, they are “politicos,” they make accusations. Maybe they are violent, malicious. They spread rumors and gossip to gain their ends—all for the good of the fellowship! We have to learn that these people, who may be a trifle sicker than the rest of us, need not be destructive at all, depending on how we relate ourselves to them.

If we are the target, we ought to listen carefully to what they say. Sometimes they are telling the whole truth; at other times, a little truth. More often, though, they are just rationalizing themselves into nonsense. If they speak even a little truth, we had better thank them, take our respective inventories, and admit we were wrong. If it is nonsense, we can ignore it or lay all the cards on the table and try to persuade them. Failing this, we can be sorry they are too sick to listen and try to forget the whole business. There are few better means of self-survey and of developing genuine patience than the workouts these usually well-meaning erratic members afford us. This is a large order and sometimes we shall fail to make good on it, but we must keep trying.

Now we come to the all-important attribute of vision. Vision is, I think, the ability to make good estimates, both for the immediate and for the more distant future. Some might feel this to be heresy. But the valuable principle of “one day at a time” really refers to our mental and emotional lives and means that we are not to repine over the past nor daydream about the future.

As individuals and as a fellowship, we shall surely suffer if we cast the job of planning for tomorrow onto a fatuous

idea of Providence. God has endowed human beings with considerable capability for foresight and evidently expects us to use it. Therefore, we must distinguish between wishful fantasy and thoughtful estimate. This can spell the difference between future progress and unforeseen woe.

Of course we shall often miscalculate the future in whole or in part, but that is better than to refuse to think about it at all. The making of estimates has several aspects. We look at past and present experience to see what we think it means. From this we derive a tentative idea or policy. First, we ask how this idea or policy might work in the near future. Then we ask how it might apply under differing conditions in the longer future. If an idea seems good, we try it experimentally, when that is possible. Later, we evaluate the situation and ask whether our estimate is working well.

At this stage, we may have to make a critical decision. Maybe our policy or plan still looks fine and is apparently doing well. Nevertheless, we ought to ponder carefully its longtime effect. Will today's advantages boomerang into liabilities for tomorrow? The temptation might be to seize the immediate benefits and forget the harmful precedents or consequences that might result.

We have found we must use these principles to estimate constantly, especially at World Service levels, where stakes are high. We must think about our service needs as they relate to general economic conditions, group capability, and willingness to contribute. We often must try to think months and years ahead.

Such is the process of estimating the future. Responsible world leadership must be proficient in this vital activity. It is an essential ability, especially in our Trustees. Most of them should be chosen on the basis that they have already demonstrated foresight in their activities for the fellowship and in their own careers.

Thank God that so many of our service leaders at all levels of operation are blessed with the attributes of tolerance, responsibility, flexibility, and vision.

# Concept Ten

***Service responsibility is balanced by carefully defined service authority and double-headed management is avoided.***

The guarantee of harmonious and effective function of good operational structure is in the relation of its several parts and people, so that none can doubt the nature of their respective responsibilities and corresponding areas of authority. Unless these relationships are well-defined and those holding the final authority are able and willing to delegate suitable operational authority; unless those holding such authority feel able and willing to use it freely as trusted servants; and unless there exists some definite means of interpreting and deciding doubtful situations—then personal clashes, confusion, and ineffectiveness will be inevitable.

The matter of responsibility and its necessary and co-equal authority is of such urgent importance that it might be profitable to recapitulate what has already been said, meanwhile taking a bird's-eye view of our entire structure to better envision how this principle does, and always must, apply in our every activity and attitude.

The first characteristic that any working structure must have is a point, or succession of points, where there is ultimate responsibility and ultimate authority. We have already seen how, for Al-Anon's World Service, this kind of final responsibility and authority resides in the Al-Anon groups themselves. And they, in turn, have entrusted some of their ultimate authority to the Conference and the Board of Trustees.

We have observed how the Conference Delegates, directly representing the groups, are actually in a position of ultimate authority over the Trustees. We have seen further how the Trustees are in ultimate authority over the selected and Executive Committees of the World Service Office.

The principle of ultimate authority runs through our entire structure. This is necessary, because all our service affairs and activities must be directed to the point at which final responsibility rests, so that each worker, or each group of workers, knows who makes final decisions.

If, however, authority is not specifically delegated, we would have the opposite result: The groups could direct their Delegates on every important issue; the Delegates could similarly turn the Trustees into

a spineless committee to be given specific direction on almost every matter; likewise, the Trustees could regard themselves as the sole directors of the service entities, making automatons of the working staff. In short, such a misuse of ultimate authority would add up to a dictatorship in which nearly every classification of Al-Anon servants would have large responsibilities but no definite authority, and hence no capability of effective decision and leadership. Big or little tyrannies and buck-passing would be the inevitable consequence.

Therefore, it is clear that ultimate authority is not something to be used indiscriminately. Indeed, ultimate authority should practically never be used in full, *except in an emergency*. That *emergency* usually arises when delegated authority has erred, when it must be reorganized because it is ineffective, or because it constantly exceeds its defined scope and purpose. For example, if the groups are dissatisfied with the Conference, they can elect better Delegates or withhold funds. *If the Conference must, it can censure, and under certain circumstances, it can bring about the reorganization of the Board of Trustees. (See Al-Anon World Service Conference Charter.)* The Trustees can do the same with the service committees.

These are the *proper* uses of *ultimate authority*, because they correctly discharge an ultimate responsibility. The *influence* of ultimate authority must always be felt, but it is perfectly clear that *when delegated authority is operating well, it should be left alone*. Otherwise those charged with operating responsibility will be demoralized, because their work will be subject to arbitrary invasion, and the demands made upon them would be greater than their authority.

Let us review the foregoing Concepts and note how, at each structure level, accurate definitions of authority and responsibility have been given. This has been done by (a) traditional means, (b) legal means, and (c) by principles under which doubtful or conflicting situations can be interpreted and resolved.

- a. Consider the Conference Charter. It is not a legal instrument, but practically speaking, it is substantially a contract between the Al-Anon groups and the Conference. The Charter indicates that the Al-Anon groups have delegated complete administrative and operational authority to the Conference and its service arms. It further suggests that each Conference member be entitled to cast his ballot according to the dictates of his own conscience; that the Conference itself also be granted, under the traditional Right of Decision, the privi-

lege of choosing which matters it will decide and which it will refer back to the groups for their discussion, guidance, or direction. These are the traditional definitions designed to check the natural tendency of the groups to overinstruct Delegates. This gives the Conference an authority equal to its responsibility.

- b. Consider next the position of the Trustees. It has already been stated that although the Conference has the ultimate authority, the Trustees must have the legal right to actively administer our service affairs. Their legal right has been further strengthened and its use encouraged by the traditional Right of Decision. We recognize also that the Trustees have a legal right of veto over the Conference when, in rare cases, they feel it should be used. By these means we have guaranteed the Trustees administrative authority equal to their actual responsibility. The position of the Trustees is further strengthened by their voting participation in the Conference and by the recognition that they are Al-Anon's primary World Service administrators. All this, of course, does not deny in any way the ultimate authority of the Conference, should it be necessary to give the Trustees directives or censures or to reorganize the Board.

Much care has also been taken to guarantee the Executive Committee an ample operating authority that fully matches its responsibility for the routine conduct of our active services. The same would be true of any later-formed committees or boards. However, the legal authority of the Trustees over all of its subsidiary committees and boards is not only ultimate it is absolute the moment the Trustees have reason to make such a decision. They can disband or name committees or boards at any time; they control the budget and can withhold operating funds. Nevertheless, so long as things go well, it is highly important that the Trustees do not unnecessarily interfere with or usurp the operating authority of these entities. Hence the care taken in constructing these definitions of delegated authority.

To a considerable degree, the selected committees of the World Service Office have similar latitude. Under the principle of the Right of Decision, each primary committee may choose what business it will dispose of and what business it

will refer to the Trustees. The position of these committees is also fortified by the appointment of a generous proportion of non-Trustee members. Here, too, provision has been made to equalize the authority of these committees with their responsibility.

- c. Now we come to the matter of conflicting authority and how these conflicts are to be resolved. Most routine conflicts in the active services are easily settled, because ready communication has been provided between all service committees and boards.

In all matters of joint or conflicting authority, a primary jurisdiction must be established, an understood point or body where a final settlement can be reached. The secondary jurisdiction must also be heard. Minor conflicts will not need to be referred to the Trustees, but the *point of final decision is always located there*.

Suppose, for example, a plan for creation or expansion of service develops that involves interpretation or application of the Traditions or policies. It first goes to the Policy Committee. If the Policy Committee approves the plans, it recommends them to the Board of Trustees. The Board of Trustees determines what matters it will approve and what it will delegate to the Executive Committee.

However, if the project is not budgeted, the plans will first have to be submitted to the Finance Committee. If the Finance Committee decides the expenditure is in line with the overall budget or financially feasible, it makes its recommendation to either the Executive Committee or the Board of Trustees.

Primary and secondary jurisdiction also works the other way around. If the Executive Committee approves any new or expanded service project that involves interpretation or application of the Traditions or policies, it sends it to the Policy Committee. Once the Policy Committee finds it is within the Traditions and policies and the Finance Committee finds it is financially feasible, the Executive Committee recommends it to the Board of Trustees for final decision.

A condition to be avoided at all costs is *double-headed* business or policy management. Authority can never be divided into equal halves. Nowhere does such split authority so bedevil a structure as in its executive departments (see Concept Eleven).

In addition to the methods we use to make delegated authority equal to delegated responsibility, we have two more guarantees—the Right of Appeal and the Right of Petition. As mentioned in Concept

Five, a bare majority may constitute a pseudo-ultimate authority on many occasions when it is not warranted. Likewise, executives may excessively supervise their staff. Therefore, we use the concepts of Appeal and Petition to ensure that every minority and every worker who does a job has an authority and a status commensurate with the responsibility involved.

To sum up: Let us always be sure that there is an abundance of final or ultimate authority to correct or to reorganize; but let us be equally sure that all of our trusted servants have a clearly defined and adequate authority to do their daily work and to discharge their clear responsibilities.

All of this is fully implied in Al-Anon's Tradition Two. Here we see the "group conscience" as the *ultimate* authority and the "trusted servant" as the *delegated* authority. One cannot function without the other. We well know that only by means of careful definitions and mutual respect can we constantly maintain a harmonious working balance.

## Concept Eleven

***The World Service Office is composed of selected committees, executives, and staff members.***

While the Trustees hold final responsibility for Al-Anon's world service administration, they should always have the assistance of the best possible committees, executives, staff, and consultants. This means careful consideration of these committees, the personal qualifications of their members, the manner of their induction into service, the way in which they relate to each other, and the special rights and duties of our executives, staff, and consultants.

The long-range success of our World Service Office (WSO) will rest not only on the capabilities of the Trustees but also upon the competent leadership and harmonious association of those committee members, service directors, executives, and staff members who actively carry on Al-Anon's world services. Their quality and dedication, or their lack of these characteristics, will make or break our structure of service. Our dependence on them will always be great.

Staff members are in direct contact with Al-Anon worldwide through correspondence and/or travel. Their performance is constantly on view by visitors to the WSO. They perform most of the routine tasks



and carry on most of our services. They often develop and implement new plans and policies. Because this group is the visible image of world service, most Al-Anon members evaluate our service by what they see and feel in them. These staff members not only *support* the world leadership of the Trustees, they *share* world leadership with them.

With the approval of the Board of Trustees, its Chairperson annually appoints committee Chairpersons. The committee Chairpersons, in consultation with staff liaisons, select the At-Large or advisory members who are then approved by the Board. The Chairperson of the Board and the Executive Director are ex officio members of each committee. *Staff members are represented on each committee. Conference Delegates also serve on a number of these committees.*

**Selected Committees:**

- Admissions/Handbook\*\*
- Alateen Advisory
- Archives Advisory\*\*
- Conference Leadership Team (formerly Conference\*\*)
- Conference Committee on Trustees (CCT)
- Finance\*
- Forum Editorial Advisory
- Group Services\*\*
- International Coordination
- Literature
- Nominating\*
- Outreach to Professionals Advisory\*\*
- Policy\*
- Public Outreach
- Regional Committee on Trustees (RCT)
- Regional Service Seminar\*\*

None of these service committees are executive in character. They do not manage or conduct the active affairs of the service departments.

The Admissions/Handbook\*\* is a subcommittee of the Conference Committee\*\*. The Conference Committee on Trustees and the Regional Committee on Trustees are subcommittees of the Nominating Committee. Advisory committees and subcommittees make recommendations to their parent committees. Other com-

*\*Committees having permanent status, sometimes referred to as standing committees.*

*\*\* This Committee is no longer used in World Service Conference (WSC) Structure; however, the Committee may be functioning in worldwide General Service Offices or evolving structures that look to the WSC for guidance.*

mittees make recommendations to the Executive Committee or to the Board of Trustees. From time to time, ad hoc committees and/or task forces may be established to fulfill a specific, limited purpose. Ad hoc committees and task forces report to the entity that appointed them.

**Policy Committee:** This is perhaps the most important of all the World Service Office (WSO) committees. It can exercise authority over issues or projects that involve Al-Anon policy, public relations, or the Traditions, as these may arise in other WSO committees. It is empowered to consider any issues or projects submitted by an Al-Anon member, or to reconsider a decision already made if any part of the fellowship dissents.

The Policy Committee makes recommendations to the Board of Trustees, and also reports minority views. In an emergency, when immediate action is necessary, its decision is binding so far as that particular incident is concerned. But this decision does not necessarily become part of the overall policy, unless approved by the Board of Trustees and the World Service Conference. [See Appendix for A.A.'s General Policy Committee.]

The Policy Committee is composed of a Chairperson, all members of the Board of Trustees, members of the Executive Committee, and the Conference members of the WSO administrative staff. It meets quarterly in advance of the Trustees' meeting.

**Finance Committee:** The primary function of this Committee is to see that our World Service Office (WSO) operation remains financially sound, always aligning the use of our money with the spiritual principles of our program.

This Committee conservatively estimates each year's income. It develops plans for increasing our revenues and keeps a watchful eye on expenditures. It scrutinizes the annual budgets of estimated income and expense submitted by the WSO, and makes revisions when necessary. The Committee also sets literature pricing in a way that adequately supports the needs of the service structure.

This Committee may be compelled to risk temporary deficits. However, uncontrolled spending could result in the collapse of vital services. On the other hand, fearful hoarding could result in the severe curtailment of such services. Both should be guarded against with great care.

When appropriate, the Finance Committee recommends that the Board of Trustees set aside sums in the Reserve Fund (Warranty One) with the assurance of the immediate availability of those funds.

This Committee is composed of a Chairperson (Treasurer of the Board of Trustees), the Chairperson of the Board of Trustees, the Chairperson of the Executive Committee, the Executive Director, and a volunteer member of either the Board of Trustees or the Executive Committee. This volunteer member is appointed by the Chairperson of the Board and approved by the Trustees each year at the Annual Meeting. The Director of Business Services is an ex officio member of the Committee.

**Nominating Committee:** This Committee aids the Trustees in discharging their prime obligation to see that all vacancies within the Board of Trustees or its Executive Committees are filled with those of the greatest possible competence, stability, and industry.

This Committee makes recommendations that will determine, to a large extent, the continuous success of our services.

In making its recommendations for Trustee at Large and Regional Trustee candidates, the Nominating Committee evaluates and reviews the written input of each member of the Conference Committee on Trustees and the Regional Committee on Trustees as part of its careful deliberation.

The Nominating Committee refuses to accept casual recommendations in its selection of candidates for Trustee at Large, Regional Trustee, and AtLarge members of the Executive Committees (see also Concept Eight).

**Conference Committee on Trustees:** In 1984, the Conference Committee on Trustees (CCT) was formed. The CCT, a subcommittee of the Board's Nominating Committee, is composed of World Service Conference Delegates and elects its own Chairperson annually.

The members of the CCT independently review and evaluate résumés submitted for Trustee At-Large and résumés for At-Large members of the Executive Committee for Real Property Management. A compilation of their reviews is provided to the Nominating Committee to assist it in the selection of candidates to be presented to the Board.

**Regional Committee on Trustees:** The process for the election of Regional Trustees, accepted by the 2010 WSC, includes the formation of a Regional Committee on Trustees (RCT) for each of those Regions nominating a Regional Trustee in that year. The RCT is a subcommittee of the Board's Nominating Committee, and is composed of all World Service Delegates from that Region plus additional Delegate(s) from outside the Region. Each RCT elects its own Chairperson.

The members of each RCT independently review and evaluate résumés submitted by Areas, within that Region, for candidates for Regional Trustee. A compilation of their reviews is provided to the Nominating Committee.

**International Coordination Committee:** In 1978, the International Coordination Committee (ICC) was formed as an avenue of communication to support the international growth and to perpetuate worldwide unity of Al-Anon and Alateen.

The ICC is an advisory committee to the Board of Trustees. The Committee coordinates the International Al-Anon General Services Meeting (IAGSM) and reviews the activities of the World Service Office (WSO) as they relate to those individuals, groups, and service arms outside the Areas served by the World Service Conference (WSC) Structure. It also considers firsttime requests for permission to reprint Conference Approved Literature (CAL) outside the WSC Structure.

The ICC provides guidance to groups worldwide as they endeavor to form General Service Office structures within their own countries.

**Conference Leadership Team (Conference):** The Conference Leadership Team has the responsibility to prepare a World Service Conference agenda that facilitates the active voice and effective group conscience of our fellowship.

To foster communication regarding the work of the Conference, *Conference Summaries* are available to all members.

**Admissions/Handbook Committee\*\*:** The Admissions/Handbook Committee\*\* is a subcommittee of the Conference Committee\*\*. The Committee reviews and recommends requests for seating nonvoting participants at the World Service Conference (WSC). It determines if an Area meets the criteria for seating at the WSC, and reviews requests for an Area name change. It makes recommendations for changes in the “World Service Handbook” section of the *Al-Anon/Alateen Service Manual*.

**Archives Advisory Committee\*\*:** This Committee is concerned with preserving and organizing historical Al Anon/Alateen material. It recommends to the Executive Committee current preservation and archival record management techniques to further the ongoing maintenance of those materials. It also acts in an advisory

---

\*\* *This Committee is no longer used in World Service Conference (WSC) Structure; however, the Committee may be functioning in worldwide General Service Offices or evolving structures that look to the WSC for guidance.*

capacity to the World Service Office (WSO) in making the archives available to the staff, volunteers, membership, and researchers.

**Forum Editorial Advisory Committee:** This Committee selects sharings suitable for publication, and through a process of review and assessment, recommends to the editorial staff articles for inclusion in various sections of the magazine. The Committee critiques previous issues. In reporting to the Executive Committee, it suggests reader surveys, reviews proposed survey text, and considers the results.

**Group Services Committee\*\*:** In 1996, this Committee was created to respond to the needs expressed by our fellowship as a whole. The Delegate Committee members bring the shared experience of their Areas so that the Committee can offer recommendations to the World Service Office (WSO) on how to best serve the membership.

**Alateen Advisory Committee:** The Alateen Committee was restructured as an advisory committee to the Group Services Committee\*\*. This Committee identifies and articulates the needs of teenage members of the fellowship to assure that Alateen interests are considered in Group Services Committee decisions and activities. This Committee is composed of members of both Al-Anon and Alateen.

**The Literature Committee:** This Committee is responsible for all Conference Approved Literature (CAL) and its mission is to see that every aspect of the Al-Anon program of recovery is presented in comprehensive written material for our members, friends, and the world at large. The Committee suggests creation of material to meet new needs or changing conditions, and is charged with the revision of existing books and pamphlets.

Our literature is a principal means for facilitating Al-Anon's growth, unity, and service. The influence of the many thousand books and pamphlets distributed each year is incalculable. For these reasons, Al-Anon's policy is to produce only highquality literature.

**Public Outreach Committee:** This Committee is the umbrella under which we try to reach families and friends of alcoholics and professionals who work with them, through a variety of media and communication vehicles.

The Committee assists in the development of educational tools for our members to use with a variety of outside audiences to inform them of what Al-Anon/Alateen is and how it can be an effective resource for families and friends of alcoholics, and attract new members to our fellowship without compromising our Traditions.

*\*\* This Committee is no longer used in World Service Conference (WSC) Structure; however, the Committee may be functioning in worldwide General Service Offices or evolving structures that look to the WSC for guidance.*

**Outreach to Professionals Advisory Committee\*\*:** The Cooperating with the Professional Community (CPC) Committee was restructured as an advisory committee to the Public Outreach Committee. The work of outreach to facilities and institutions was also delegated to this Committee.

This Committee follows Bill W's suggestion of being friendly with our friends, the professionals. The broad objective of the Committee is to make Al-Anon/Alateen's purpose better known to professionals at a national level.

The Committee works to improve cooperation between Al-Anon and the professional community, institutions, and organizations at a national level by providing information about who we are, what we are, where we are, and how we can cooperate with them.

**Regional Service Seminar Committee\*\*:** This Committee shares ideas from Region to Region and recommends ways to make the Regional Service Seminars more effective.

## Executives

Any active service, to function well, must be managed by a competent Executive. It must always be directed by *one person*, supported by such staff as needed. This function must be delegated to an individual with ample freedom and authority to do the job without interference, so long as the work is done well.

Good executives possess a special combination of abilities, one of which is the ability to lead by example, thus securing willing cooperation. If that cooperation is lacking, action must be readily taken without favor or partiality. An executive is often the one who takes the initiative in planning. When making new plans and putting them into operation, consultation must be held with those whose experience and wisdom are actually or officially required.

A good executive knows when to ask for specific definitions and directions and when to make decisions. This choice is structurally guaranteed by Concept Three (Right of Decision). If there is an error in judgment or if authority is exceeded, the decision can be reviewed.

## Staff Members

Certain key people at the World Service Office (WSO) must be Al-Anon members. Some of these key paid personnel have a vote on our Committees and Corporate Boards. It is not a requirement

---

*\*\* This Committee is no longer used in World Service Conference (WSC) Structure; however, the Committee may be functioning in worldwide General Service Offices or evolving structures that look to the WSC for guidance.*

that clerical staff be Al-Anon members. It is important that all be treated fairly. As in the management of any business, the prime consideration is getting the job done well.

At our World Service Office we treat our paid workers in all respects as we do our volunteers. Our employees are part of the team. The fact that our employees receive a salary from the WSO should never, consciously or unconsciously, be used as a lever against them. To do so would be neither good spiritual practice nor good business. When we can afford it, every employee should be compensated in relation to those offering similar services and abilities in comparable notforprofit organizations.

No organizational structure can fully guarantee the WSO against the possible damage done by clashing personalities. If, however, our paid staff cannot or will not do their jobs, we can and should let them go.

By our sustained willingness to practice spiritual principles in all our affairs, we can realize these ideals.

## Concept Twelve

***The spiritual foundation for Al-Anon's world services is contained in the General Warranties of the Conference, Article 12 of the Charter.***

In order that the Conference shall never become the seat of perilous wealth or power, the General Warranties of the Conference read: "In all its proceedings the World Service Conference of Al-Anon shall observe the spirit of the Traditions":

1. that only sufficient operating funds, including an ample reserve, be its prudent financial principle;
2. that no Conference member shall be placed in unqualified authority over other members;
3. that all decisions be reached by discussion, vote and, whenever possible, by unanimity;
4. that no Conference action ever be personally punitive or an incitement to public controversy;
5. that though the Conference serves Al-Anon, it shall never perform any act of government, and that, like the fellowship of Al-Anon Family Groups which it serves, it shall always remain democratic in thought and action.

Our Conference Charter is an informal agreement made between the Al-Anon groups and their Trustees in 1967 and is the basis upon which the World Service Conference operates. In general, the Charter is a flexible document, since its first eleven articles can be readily amended by the Conference at any time.

But Article 12 stands by itself. An amendment or cancellation of any of its vital Warranties would require the written consent of three-quarters of all *registered* Al-Anon groups. Each group should vote on any such proposals after taking at least six months for careful deliberation. Thus, changes in the Warranties have been made difficult but not impossible.

It is believed that all of these Warranties are permanently important to Al-Anon's general welfare. A change in them should be made only upon positive evidence of some defect, and then only by common consent of the Al-Anon groups. They rank, therefore, with the Twelve Traditions and are as important to Al-Anon's world services as the Traditions are to the groups.

All the Warranties counsel prudence—prudence in personal relations, prudence in money matters, and prudence in our contacts with the world around us. For Al-Anon, prudence is a middle ground, a channel between fear on the one hand and recklessness on the other. Prudence creates a climate of harmony, effectiveness, and consistent spiritual progress. These Warranties express the wisdom of taking thought for the future based on lessons of the past. They protect us against needless errors and the natural human temptations of wealth, prestige, and power.

The Conference, above all, should feel bound by the Al-Anon Traditions. Indeed, the Conference is named “the guardian of the Traditions.” The Traditions, which express the principles and attitudes of prudence, set the pattern of unity and of function which our World Service Conference is expected to exemplify.

“In order that the Conference shall never become the seat of perilous wealth or power” does not mean that the Conference should have virtually no money and no authority. We must have some money, and there must be some authority. But how much? How and where should we draw the line?

The principal protection against too much money and too much power is found in the Traditions themselves. As long as our Board of Trustees refuses to accept outside contributions and sets a limit on each member's gift to Al-Anon's world services, we shall not



become wealthy to a perilous degree. Indeed, it seems that the chief difficulty will continue to be that of effectively informing the Al-Anon groups as to the actual financial needs of the World Service Office and their responsibility to support it. It is unlikely, therefore, that we shall ever become too wealthy through group contributions. We need only avoid the temptation of accepting money from the outside world.

There can be little risk either in giving Delegates, Trustees, and staff the necessary authority. Experience indicates that we are unlikely to encounter problems of too much service authority. On the contrary, our difficulty may be to maintain enough of it. We are protected from too much authority by participation, by the Right of Appeal, and by our Charter. A leader who demands too much authority could not long remain in leadership. Our Delegates, directly representing the groups, control the ultimate supply of our service funds. This constitutes a direct check upon the rise and use of personal power. Taken altogether, these factors should be reliable safeguards against too much money and too much authority.

Another sort of authority and power that the Conference cannot be without is the spiritual power that flows from the activities and attitudes of truly humble, unselfish, and dedicated Al-Anon servants. They do not rule by mandate, they lead by example. This is the real power that makes our Conference function.

**[The wording of the Warranties in this section is an adaptation, by our co-founder Lois W., of A.A.'s Warranties. It is retained here for historical purposes and because it has been in common usage since the adoption of this *Manual* by the 1970 WSC. The formal wording of the Warranties can be found in the Conference Charter .]**

## Warranty One

***Sufficient operating funds, including an ample reserve, should be its prudent financial principle.***

Our attitude toward giving time, compared with giving money, presents an interesting contrast. We give much time to Al-Anon activities for the sake of our groups, our Areas, and Al-Anon as a whole, as well as for our own protection and growth. We often take time from home duties or business to do Twelfth Step work. We do

not think these sacrifices are unusual. We remember that people once gave their time to us as we struggled for understanding.

But when it comes to the spending of cash for Al-Anon service overhead, many of us turn reluctant. When we drop money in the meeting basket, its usefulness is not as obvious as when we talk to a newcomer. There is no romance in paying the landlord. Sometimes we hold back when asked to meet area or Intergroup service expenses. As to world services, we may remark, "Well, our group doesn't get anything out of it. Let's not spoil Al-Anon with money and service organization. Let's keep things simple."

These reactions are natural and understandable, easy to justify. But they quickly disappear when the real need for a given Al-Anon service is made clear by right information and education. We see this in the ever-better job now being done by Delegates, District Representatives, and Group Representatives, who know that raising money by pressure and exhortation is not needed in Al-Anon. When each member can be shown how much the service dollar really buys in terms of helping families to find Al-Anon, contributions are willing and generous.

We can take comfort, too, from the fact that the cost of our world services is small in relation to the size of our fellowship. Our paid workers at the WSO are comparatively few.

Not until 1966 was the Board of Trustees able to establish a savings account that later became a reserve fund. Each year before then the Trustees hoped and prayed that the budget would be met by contributions and literature sales. Fortunately this turned out as they hoped. But such a hand-to-mouth system of finance, although inevitable in our early years, was not a prudent one for the future.

Group contributions pay for only a portion of the World Service Office expenses; the balance is financed by the sale of literature. It is firmly believed that, as the groups understand the situation more clearly, their contributions will continue to increase, so that the World Service Office can maintain a sufficient reserve to carry it through an emergency, such as a financial depression.

### **Is a Reserve Fund needed?**

In 1969, our headquarters operation was breaking even. Compared with earlier days, this was wonderful. Nevertheless this was in a period of great prosperity. The Board of Trustees, at its Annual Meeting in 1970, formally established the Reserve Fund with the following stated purposes:

1. To assure continuation of essential services in the event of substantial decline in income.
2. To cover cost of special projects which could not be financed from normal sources of income.

What would it be like in bad times without a reserve? Suppose the WSO income were greatly decreased by a depression, or expenses increased by a steep inflation. We might be faced by a gaping deficit that would make it necessary to discharge some of our paid workers. Mail would go unanswered; requests for information would not be properly serviced. *The Forum* might have to be reduced to its former size. The number of Delegates attending the annual World Service Conference might have to be drastically reduced. These could be the penalties if we did not have a Reserve Fund to fall back on. Is it not wise for us to increase our savings whenever possible, especially in good times?

**If the Reserve Fund continues to grow, will “perilous wealth” result?**

There are so many present needs for more working capital that it is hard to imagine having too much. Many outreach opportunities are becoming available to Al-Anon. Our continuous growth increases salary expenses as more staff is needed. Staff and volunteers are often invited to travel to different parts of the world to carry the Al-Anon message. Translators and translations are needed. Members of the WSO are asked to visit distant groups as speakers at anniversaries, conventions, service events, etc. If there were more funds available, Headquarters could encourage this. There is nothing like personal contact for arousing interest and enlarging understanding.

The Reserve Fund would never be permitted by the Conference to become excessive.

**Will the presence of such a fund discourage group contributions?**

We believe that further education will help the groups understand the need of such a fund and that it will have little or no effect on their contributions.

**Does the establishment of a Reserve Fund mean that we lack faith in God’s providence?**

Are we not expected to exercise a reasonable amount of foresight in the conduct of our affairs? This is certainly no denial of faith in God’s providence; it is instead a willingness to shoulder our own clear responsibility.

**Should our books and other literature be sold at cost so that hard-pressed members could purchase them more easily; or sold for less to encourage the general public to buy them?**

No, because this would mean sacrificing the support of Al-Anon's world services for small financial advantages to individual members. Experience shows that without a modest profit on literature, the WSO could not pay for its many worldwide services. Money charity to members is not the function of the group, Intergroup, or World Service Office.

If a member cannot afford to buy a book, a Sponsor may give or lend one. Many libraries carry our books. Groups sometimes sell books on the installment plan to help newcomers. If the group undertook to assist individual members financially, the group treasury, which is for the benefit of all members, would soon be dissipated. The same would be true if WSO sold books or literature at cost.

Because of its specialized character there is no reason to believe that large sales of Al-Anon literature could be made to the general public even at lowered prices. To publish in paperback would not be the answer, either: publishers tell us that paperback issues nearly always destroy the circulation of hardcover books.

**Does so-called “profit-making” on our books and pamphlets go counter to sound spiritual principles?**

Many groups, as well as the WSO, sell books for a little more than cost. Actually, this could be considered additional contributions which the member-buyers make to the general welfare of their groups or WSO. The certain and continuous solvency of our world services rests squarely upon these contributions. Looked at in this way, the Reserve Fund is seen to be the aggregate of many small financial sacrifices made by individual members for the good of the whole fellowship.

## **Warranty Two**

***None of the Conference members shall ever be placed in a position of unqualified authority over any of the others.***

The application of this principle has already been extensively discussed under Concept Four, Participation is the key to harmony. It is so important, however, that it is the subject of this Warranty, thus ensuring that Conference action alone can never overturn or

amend the Right of Participation. For such a purpose, widespread group consent would be needed, which might be difficult though not impossible for the Conference to obtain. Our whole service experience fully justifies taking this strong stand against the creation of unqualified authority at any point in our Conference structure.

This Warranty against absolute authority is far more general and sweeping in its nature than a guarantee of voting participation. It really means that we in Al-Anon do not want or need absolute human authority in any form.

Article 12 of the Conference Charter might be called “The Service Bill of Rights,” because these Warranties, and especially this one, express deep and loving respect for the spiritual liberties of our members. May God grant that we shall never be so unwise as to desire anything less.

### Warranty Three

***That all important decisions be reached by discussion, vote and, whenever possible, by substantial unanimity.***

Here, on the one hand, we erect a safeguard against any hasty or overbearing authority of a simple majority; and on the other hand, take notice of the rights and the frequent wisdom of minorities, however small. This principle further guarantees that all matters of importance will be extensively debated, until a substantial majority can support every critical decision we are called upon to make in the Conference.

The Conference voice would thus speak with authority and confidence beyond that which a simple majority could confer. If any persons remain in opposition, they are likely to be better satisfied because their views have had a full and fair hearing.

The principle of substantial unanimity does, however, have certain practical limitations. Occasionally a matter will be of such extreme urgency that a Conference decision must be made at once. In such a case a minority, however well-intended, could not be allowed to block a vitally needed action or one which is evidently in the best interests of Al-Anon. Here we shall need to trust the majority, sometimes a mere majority, to decide whether Conference debate is to be terminated and a final decision taken. In certain other cases, the majority will also have to exercise its prerogative. Suppose, for example, that a small minority obstinately tries to use the principle

of substantial unanimity to block a clearly needed action. In such an event it would be the plain duty of the majority to override such a misuse of the principle of substantial unanimity and call for a vote.

However, majorities will probably seldom need to take such radical stands. If and when they do, the Conference will have to decide, by a simple majority vote, what the requirements of substantial unanimity should be, whether two-thirds, three-quarters, or an even greater majority.

The practical and spiritual result of substantial unanimity will make itself evident.

## Warranty Four

***That no Conference action ever be personally punitive or an incitement to public controversy.***

Practically all societies and governments feel it necessary to inflict personal punishments upon individual members for violations of their beliefs, principles or laws. Because of its spiritual character Al-Anon finds this practice unnecessary. When alcoholics fail to follow sound spiritual principles, alcohol cuts them down. It is not so obvious with us in Al-Anon. It is easier for us to fool ourselves that we are right and that our indignation is justified. However, anger and resentment betray us, and we recognize we've had a "slip." Therefore no humanly administered system of penalties is needed in our fellowship. This unique condition is one on which we can fully rely and one which we should never abandon by resorting to personal attack or punishment. For much the same reason we cannot and should not enter into public controversy, even in self-defense. Nothing could be more damaging to our unity and to the goodwill Al-Anon enjoys than public contention, no matter how promising the immediate dividends might appear.

Therefore, it is evident that the harmony, security, and future effectiveness of Al-Anon will depend largely upon our maintenance of a thoroughly nonaggressive and pacific attitude in all our public relations.

If we recognize that religion is the province of the clergy, that the practice of medicine is for doctors, and that social welfare is for social workers, we can helpfully cooperate with all. Certainly there is little basis for controversy in these areas. Al-Anon has no con-

cern with reform or politics. We should strictly mind our threefold purpose.

Because our World Service Conference represents us all, it is especially charged with the duty of setting the highest possible standards with respect to these attitudes.

The Conference, however, may sometimes have to apply these principles to specific situations and take certain protective action, especially in the area of Tradition violation. This action, however, need never be punitive or aggressively controversial. When the infractions have serious implications, the WSO consults the Conference for its advice and direction. For the more routine deviations the WSO takes appropriate action, which it reports to the Conference on a timely basis.

Let us take some situations that would require consideration and decision:

- Suppose that Al-Anon falls under sharp public attack or heavy ridicule with little or no justification in fact.

Almost without exception, it can be confidently estimated that our best defense would be no defense whatever—namely, complete silence at the public level. Unreasonable people are stimulated all the more by opposition. If in good humor we leave them strictly alone, they are apt to subside the more quickly. If their attacks persist and it is plain that they are misinformed, it may be wise to communicate with them in a temperate and informative way; also in such a manner that they cannot use our communication as a springboard for fresh assault. Such communication need not be made by the World Service Office officially. Very often we can use the good offices of friends. Such messages should never question the motives of the attackers, but should be purely informative. These communications should also be private. If made public, they will often be seized upon as a fresh excuse for controversy.

If, however, criticism of Al-Anon is to any extent justified, it could be acknowledged privately, together with our thanks.

- Then we might be confronted by public violations of the Al-Anon Traditions. Individuals, outside organizations and even our own members may sometimes try to use the Al-Anon name for their own private purposes. As Al-Anon

grows in size and public recognition, the temptation to misuse our name may increase.

It has been said, “Al-Anon is prepared to give away its knowledge and experience—all except the Al-Anon name itself.” Our principles can be applied in any situation. We do not wish to monopolize them. We simply request that the public use of the Al-Anon name be avoided by those who wish to avail themselves of Al-Anon techniques and ideas. In case the Al-Anon name should be misapplied, it would of course be the duty of our World Service Conference to press for the discontinuance of such a practice—avoiding, however, public quarreling about the matter.

The Conference, as we know, is the guardian of the Traditions. But this does not imply the right nor the duty of the Conference to publicly punish or sue every willful violator. Such aggressive public acts would place the Conference in the position of having violated one of its Traditions in order to defend another.

Privately, however, violators of our Traditions can be informed that they are out of order. If they persist, our resources of persuasion may be used. Consistent firmness will often bring the desired result.

In the long run, though, we shall have to rely mainly upon the pressures of Al-Anon and public opinion. We shall need to maintain continuous education of the public through communication channels of all kinds.

Experience has shown that continuous and general education respecting our Traditions will be a reliable protection in the years to come.

- Severe internal disagreement among us that comes to unwelcome public attention is unlikely to occur in Al-Anon.

What should our World Service Conference do about this should it ever happen?

Always remembering group autonomy and the fact that Al-Anon's World Headquarters is not a government, the best course is usually to make an offer of mediation. What the Tradition means, and what our experience has been, can be recounted. Avoidance of any breakthrough to the public level should always be urged and all parties should be reminded



that an unfavorable public image could keep potential members from joining Al-Anon.

Many of these difficulties with the Traditions represent honest differences of opinion in interpretation of the Traditions. The Traditions sometimes reveal gray areas where violations are often debatable and inconsequential. In such cases we refrain from offering suggestions, unless they are insisted upon. Many such problems can be solved by the local people concerned.

- It is possible that some day might see a deep rift dividing Al-Anon—a cleavage of opinion so serious that it might involve a withdrawal of an appreciable proportion of members into a new society or one faction's making an alliance with an outside agency, ignoring the Traditions. It might be powered by religious, political, national, or racial forces. It might represent an honest effort to change for the better, but it would certainly pose a serious question of what to do.

Such a contingency is hard to imagine, yet this is no reason for refusing to give it calm forethought. If it ever came, its development might be such a terrific surprise and shock that aroused passions could flare, making any constructive solution difficult, perhaps impossible.

Particularly today, when society everywhere is in such a state of fission, this possibility must be considered. The best attitude in such a circumstance might be complete nonresistance—certainly no anger, no attack. Al-Anon has no doctrine that has to be maintained. There is no authority that has to be supported; no prestige, power, or pride that has to be satisfied. And we have no property or money that is worth quarreling about. In the event of a threatened major division, the best possible use should be made of these advantages in a calm and considered attitude of nonresistance.

We have always practiced this attitude on a lesser scale. If a member says there is too much dominance by one person in a group, we simply say, "Why don't you try another one? Or start one of your own." If individual members wish to gather together for any outside undertaking whatever, we still say, "Fine. Only we hope you won't designate such activities as an Al-Anon group or enterprise."

In the event of major division we would not waste time persuading the dissenters to stay with us. Should they become happier and more serene under new auspices and changed conditions we would ask ourselves if we could not learn from their fresh experience.

## Warranty Five

**That though the Conference serves Al-Anon, it will never perform any act of government; and that, like the fellowship of Al-Anon Family Groups which it serves, it shall always remain democratic in thought and action.**

In preceding Concepts, attention has been drawn to the extraordinary liberties that the Traditions accord to the individual member and group. No penalties are to be inflicted for nonconformity to Al-Anon principles, no fees or dues levied; contributions are always voluntary. No member can be expelled from the fellowship; membership always is the choice of the individual. Each group conducts its internal affairs as it wishes, only abstaining from acts that might injure Al-Anon or A.A. as a whole. And finally, any group of relatives and friends of alcoholics when gathered together for mutual aid may call itself an Al-Anon Family Group provided that as a group it has no other purpose or affiliation.

Because we set high value on our liberties and cannot conceive of a time when they will need to be limited, we enjoin our World Service Conference to abstain from any act of authoritative government that could curtail Al-Anon's freedoms. To maintain these freedoms the Conference must remain democratic in spirit and in action.

Therefore we expect that our Conference will always try to act with mutual respect and love, one member for another; that no action will be taken in anger, haste or recklessness; that care will be observed to respect and protect all minorities; that no action will be personally punitive; that whenever possible, important actions will be taken in substantial unanimity; and that our Conference will ever be prudently on guard against tyrannies, great or small, whether these be found in the majority or in the minority.

The sum of these several attitudes and practices is the very essence of democracy. Our freedom to serve is truly the freedom by which we live and have our being.

In 1994, the WSC agreed to the purchase of property, on a 15 year trial basis, to house the World Service Office. The motion required that the Board of Trustees establish an executive committee for the management of the real property to ensure that AFG not be diverted from its primary purpose. In 1995, the WSC passed a motion to create the Executive Committee for Real Property Management (ECRPM), also on a 15-year trial. After the completion of the trial periods, the By laws were amended in 2012, to include the ECRPM as a Committee of the Board of Trustees.

The Executive Committee for Real Property Management is composed of three at-Large Al Anon members who are not trustees, elected by the Board; the Business Manager (Director of Business Services); and the Chairperson of the Finance Committee. The Chairperson of the ECRPM is elected by the Board of Trustees from the three at-Large members. The Executive Director and the Chairperson of the Board of Trustees are not ex officio members of this Executive Committee and may not attend meetings unless invited to do so.

The Board of Trustees delegates to the Executive Committee for Real Property Management the oversight and the management of real property owned by Al Anon Family Group Headquarters, Inc.

It is within the authority of the Board of Trustees to establish other executive committees if deemed necessary.

## **Notes and Updates**

## **Notes and Updates**

# Amendments

The descriptive text of the entire “Concepts of Service” section was re-written as a result of Motion #5 at the 2002 World Service Conference (WSC): “To affirm the Board’s implementation of the revised committee structure.” The revised text was approved at the 2005, 2006, and 2007 WSCs. For ease of use, the previous text appears here in its entirety, with the amendments made over the years listed at the end.

## History of the Concepts\*

After A.A.’s General Service Office was established, Bill W. spent several years developing suitable principles and philosophies for its guidance that would coincide with the principles and philosophies of the Steps and Traditions and with A.A. experience. These are called A.A.’s Third Legacy.

Although Al-Anon is a distinct entity, our fellowship has its roots in Alcoholics Anonymous. Through our own Al-Anon experience, however, we have recognized the need for using A.A.’s three sets of principles or Legacies: the Steps, the Traditions and now, the Concepts.

A poll of the one hundred or so groups in existence in 1951 led to the adoption of the Twelve Steps as a way of life for Al-Anon members. Later, the groups accepted an adaptation of A.A.’s Twelve Traditions as a framework within which to operate.

In 1968, the Al-Anon Conference unanimously approved the idea of Al-Anon developing its own Concepts of Service.

Then in 1969, the Conference Delegates were given copies of a tentative document worked out by a committee of in-towners and out-of-towners, chaired by Lois W., portraying service Concepts that coincided with Al-Anon experience and structure. A selection of knowledgeable Al-Anon members were also sent copies. During the year, both Delegates and longtime members sent in their suggestions.

Thus, the Concepts were well considered and revised before the Conference of 1970 affirmed them as guidelines for our services.

One theme welds the three Legacies together—Pass Along Understanding:

1. Recovery—The Twelve Steps urge the individual to carry the message to others.

---

\* The 2002 Conference approved the new committee structure, which will be detailed in the next printing.

2. Unity—The Traditions protect the groups from distracting or disrupting influences, so they can be free to pass along the Al-Anon word.
3. Service—The Concepts show how Twelfth Step work can be done on a broad scale; how members of a World Service Office can relate to each other and to the groups to spread Al-Anon's message across the world; and how a conference of Delegates from all parts of the United States and Canada can supervise such a World Service, so it will always conform to the Traditions. The 1984 Conference voted that the Twelve Concepts are to be accorded the same stature as the Twelve Steps and Twelve Traditions.

## Introduction

The Al-Anon Concepts record the “why” of our service structure in such a way that the valuable experience of the past and the lessons drawn from that experience can never be forgotten or lost.

Each new generation of world servants quite rightly will be eager to make operational improvements. Unforeseen flaws in the present structure will perhaps show up in time. New service needs and problems will arise that may make structural changes necessary. These contingencies should be squarely met, and suitable alterations effected.

When structural change does seem advisable, its advocates need only present a strong case for such a change to both the Trustees and the World Service Conference for consideration. This is no more than would be required for the transaction and passage of any other piece of Al-Anon business.

For an appropriate period, any far-reaching structural change should be labeled “experimental” and such changes, as well as lesser ones, shall on final approval be entered in the body of this *Manual*. The original text will be set out at the back in an appendix, leaving the original draft of the Twelve Concepts as a record of former experience. [1]\*

Change does not necessarily spell progress. Innovations may produce little more than a painful repetition of earlier mistakes. These Concepts, it is hoped, will forestall such repetition by holding the experience of the past clearly before us. If a mistaken departure is nevertheless made, they provide a ready means of safe return to an

---

\* Bracketed numbers refer to original texts found in Amendments, pp. 266-270.

operating balance that otherwise might take years of floundering to rediscover.

The Concepts include a number of principles that have become traditional to our services but that have never been clearly defined and put into writing. For example: *Right of Decision* gives our service leaders proper discretion and latitude. The *Right of Participation* gives each world servant voting status commensurate with his responsibility and guarantees that each service board and committee will always possess the elements and talents that ensure effective functioning. The *Right of Appeal* protects and encourages minority opinion. The *Right of Petition* makes certain that grievances will be heard and properly acted upon. These general principles can, of course, be used to good effect throughout our entire structure locally, nationally, and internationally.

The Concepts also delineate those important traditions, customs, relationships, and legal arrangements that weld the Board of Trustees into working harmony with the Executive Committee and staff, the *Forum* Committee, and the primary committees of the World Service Office.

Great emphasis is placed on the need for a high order of personal leadership, careful induction methods for all incoming personnel, and the best possible relations among those who work in our services. The Concepts portray a structure in which all may labor to good effect with minimum possibility of friction. This is accomplished by a fair and balanced relationship of our workers to their work and to one another.

In service organizations there is generally a choice between authoritarian structure, in which one person or group of persons has unqualified authority, and the democratic, which calls for checks and balances. It is human nature to try to enhance one's own authority and prestige when in the saddle. But when someone else holds the reins, we tend to resist heavy-handed management. Many of us can recognize these traits in ourselves.

The Concepts define working relations that can be friendly yet efficient. They would especially restrain a tendency to concentrate on money and power, this being an underlying, though not always conscious, motivation.

It is hoped that these Twelve Concepts will be a welcome document for the use of our Trustees, the World Service Office, and the



members of the Conference and that it will prove to be a reliable working guide in years to come.

## Concept One

### ***The ultimate responsibility and authority for Al-Anon world services belongs to the Al-Anon groups.***

Tradition Two declares, “For our group purpose there is but one authority—a loving God as He may express Himself in our group conscience. Our leaders are but trusted servants; they do not govern.” This clearly implies that the groups are to be the final authority, that our leaders are to be entrusted with delegated responsibilities only.

The Al-Anon groups today hold ultimate responsibility and authority for our world services, those special elements of overall service activity that make it possible for our fellowship to function as a whole.

Our first move toward the creation of a service structure for Al-Anon was the formation, in 1951, of a central office or Clearing House, as it was then called. This Clearing House was designed to inaugurate and maintain those special services for Al-Anon as a whole that could not well be performed by single groups or Areas, such as writing uniform literature, the development of a sound public relations policy, and the handling of large numbers of pleas for help. We hoped to encourage and aid new groups to form, and to furnish them with counsel based upon experience of older and already successful groups. We thought there might be a need for a monthly magazine, and perhaps later, for translations of our literature into other languages.

If Annie S., A.A. Doctor Bob’s wife, had lived until 1951, she would undoubtedly have given great moral support to the efforts to open a service office. Her death in Akron, Ohio, in 1949 was a great loss to us all, for Annie had carried the message to many an alcoholic’s relative. A.A. families in Akron consulted her constantly, and whenever she visited A.A. groups with Doctor Bob, she always told the wives how she had adopted the A.A. principles as a way of life for herself and urged them to do likewise. A number of Al-Anon groups in the Midwest were started in this manner, as were many in the East, where wives of early A.A.s traveled from group to group and talked about their experiences and needs.

When Bill W. was trying to inspire the formation of an A.A. conference of delegates in 1950 by visiting many groups throughout the United States and Canada, he ran across quite a few groups of wives of A.A.s who met for a variety of purposes. Upon his return, he mentioned that these groups needed a unifying center to which they could write for information and suggested that his wife, Lois, establish such an office.

Thereupon Lois and another Anne, Anne B., working in the former's home in the suburbs, began by asking A.A. whether they had the names of any A.A. wives' groups. Surprisingly, there were 87 names of families and groups of wives who had asked A.A. for help. Lois and Anne wrote to them, and 50 registered immediately. As correspondence increased, the office was moved to New York City, where more help was available.

At its start, the Clearing House polled the groups on the major questions of name, purpose, and method of support for our fellowship and the adoption of A.A.'s Twelve Steps and Twelve Traditions, slightly modified for Al-Anon's use.

In 1954, the Clearing House was incorporated as a nonprofit unit under the title Al-Anon Family Group Headquarters, Inc., directed by a Board of Trustees consisting of volunteer Al-Anon members.\*

By 1960, many of our dreams for world service had come true. In nine years Al-Anon membership had jumped from 50 groups to nearly 1,500. Unity of purpose had pretty much replaced the early dissimilarity of groups. The A.A. Auxiliary and "Coffee and Cake" groups had fallen away or been changed to real Al-Anon, as had many of the early A.A. wives' groups. The basis for membership had broadened. Membership in many groups was 50 percent or more families of alcoholics who did not belong to A.A. and perhaps never would. National publicity had brought in hundreds of members who had no contact with Alcoholics Anonymous. Al-Anons were confidently united in their purpose of helping themselves in order to help others—and indirectly the alcoholic—and to do this through the use of the Twelve Steps and Twelve Traditions.

As Al-Anon entered its second decade, polling groups on important issues became impractical. The procedure was slow and cumbersome, and because many groups did not respond to letters, polls were ineffectual and sometimes inaccurate. There were also constant questions of policy that could not be settled by a poll and on

---

\* For details of the structure of the World Service Office, see Concept Eleven.

which wrong decisions might lead to ultimate disaster. The group conscience had to point a way on these matters.

It was in order to meet this need that the Al-Anon groups in 1960 voted for the formation of the Al-Anon World Service Conference.

## Concept Two

***The Al-Anon Family Groups have delegated complete administrative and operational authority to their Conference and its service arms.***

The many Al-Anon groups scattered all over the world hold in their hands the group conscience.

But it is evident that, in order to get effective action, the groups must delegate the actual operational authority to chosen service representatives who are empowered to speak and act for them. The group conscience of Al-Anon could not be heard unless a properly chosen Conference were fully trusted to speak for it in most world service matters. Hence the principle of delegated authority and responsibility to our trusted servants must be implicit from the top to the bottom of our active service structure.

Our World Service Office had taken on a crucial meaning for Al-Anon's future. If this vital center were to collapse or bog down, our unity within—and the carrying of our message to innumerable potential members without—would suffer serious and perhaps irreparable damage. Were we ready to take the precautions A.A. had taken to guard against impairment and to establish a Conference of Al-Anon Delegates to whom our service headquarters would be accountable?

Many of us thought we were ready. Also we recognized that the average member, preoccupied with group life and personal Twelfth Step work, knew little if anything about Al-Anon's worldwide activities. Few Al-Anons realized how much their group membership and unity were due to the little-noticed activities of our headquarters office.

A few at headquarters felt this attitude showed a lack of faith in Al-Anon. They said: "Why change? Things are going fine. We poll the groups' opinion on any important question. Delegates from all over the country will mean expense and politics. We don't want either; let's keep it simple."

However, the decision lay with the groups. In 1960, Al-Anon held a meeting at the A.A. International Convention in Long Beach, Cal-

ifornia. There this matter was discussed. AI-Anons from all over the United States and Canada had come to this convention. Their vote on the question would represent a cross-section of all AI-Anon. Those present voted unanimously to set up an annual Conference of Delegates on a trial basis for three years. This action was later confirmed by a poll of the groups.

Some years after the Conference had become a permanent foundation for AI-Anon world services, we found that our fears had been largely groundless. Its success has exceeded our highest expectations. It proved that the AI-Anon groups can and will take the final responsibility for their world services.

Our World Service Conference is the active voice and the effective group conscience of our society in world affairs.

We believe our fellowship is a spiritual society characterized by enough enlightenment, responsibility, and love for God and man to ensure that our democracy of world service will work under all conditions. We rely confidently on Tradition Two, our group conscience, and our trusted servants. Hence it is with a sense of great security that we old timers now are assured that AI-Anon's World Service Conference will use its vested authority for giving shape to the destiny that God is holding in store for us all.

### Concept Three

#### ***The right of decision makes effective leadership possible.***

Within the framework of their general responsibilities, whether these be defined by charter, resolution, or custom, it should be traditional for all world service boards, committees, and executives to decide which matters they may properly dispose of and on which they will report, consult, or ask specific directions. Our world servants should be trusted with these discretions, otherwise no effective leadership is possible. Let us consider why the Right of Decision is imperative for our leaders. Let us examine this principle in its practical application to all levels of our world service structure.

The Charter of the Conference and the Bylaws of AI-Anon Family Group Headquarters, Inc., define in broad terms the responsibility of the Conference to act on behalf of AI-Anon as a whole. In these two documents, a large area of delegated service authority and responsibility has been spelled out. These instruments describe the relationships between the groups, the Conference, the Trustees,

and the active service units. These broad definitions and descriptions are an indispensable frame of reference; we could not function without them.

Nevertheless, it has long been evident that the Charter and the Bylaws, important as they are, cannot by themselves ensure smooth functioning and proper leadership at the various levels of service. For example, knowing that they have the final authority, the groups may be tempted to instruct their Delegates exactly how to vote. There is no doubt that the Al-Anon groups have the right to do this. They can give directives to their Delegates on any and all Al-Anon matters.

But good management seldom means the full exercise of ultimate rights. Were the groups to carry their instruction of Delegates to extremes, we would be proceeding on the false premise that a group's opinion could be superior to Conference opinion. As a practical matter, this could almost never be the case. How could "instructed" Delegates settle a question as well as Conference members acting freely with full facts to guide them? It is understood that complete reporting of Conference actions is always desirable. So is full consultation with District Representatives and Group Representatives. Nevertheless, the "instructed" Delegate who cannot act according to his own conscience on a final Conference vote would not be a "trusted servant" at all but a messenger.

The Conference Charter does not actually solve typical problems like these. It is a broad document that can be construed in various ways. Under one interpretation, the groups can instruct the Delegates as much as they like. Under another, the Delegates and Trustees can actually go counter to such instructions, *whenever new information gives them reason to change their point of view.*

Let us look at another illustration: In matters of policy, principles, and program procedures, the Conference has practically complete authority over the Trustees consistent with the individual legal obligations of the Trustees and the Board respecting corporate business transactions. [2] It surely would not be practical for the Conference to issue hasty and flat directives to the Trustees on matters about which the Trustees would be far more knowledgeable than the Delegates.

Again, this same kind of confusion could beset the relations of the Trustees to the Executive Committee and to committees directed by non-Trustee volunteers and paid service workers. The Board of

Trustees certainly does have authority to control these entities; its authority is final. [3] Yet if the Trustees were to constantly exert their full and absolute authority and attempt to manage these operating entities in detail, then the volunteers and staff members would quickly become demoralized; they would be turned into buck-passers and rubber stamps; their only choice would be to rebel and resign or to submit and smolder.

Therefore, some traditional and practical principle must be applied that at all levels will continuously balance relations between ultimate authority and delegated responsibility. How—shall we accomplish this?

The Al-Anon solution to these questions is to be found in Tradition Two, which refers to “trusted servants.” This provides that our responsible leaders be trusted to decide, within the framework of their duties, how to interpret and apply their authority and responsibility to each problem or situation as it arises. This sort of leadership discretion is the essence of the Right of Decision. We need have no misgivings about granting this privilege at every level of world service.

There will always be plenty of ultimate authority to correct inefficiency, ineffectiveness, or abuse. If the Conference does not function well, the groups are free to choose better Delegates to represent them. If the Trustees get badly out of line, the Conference can censure them or even reorganize their Board. If Headquarters services should sour, the Trustees can appoint a more effective Executive Committee and hire better help. These remedies are direct and adequate. But for so long as our world services function reasonably well, then “trust” must be our watchword, otherwise we shall wind up leaderless.

The above reasons show why our service bodies and people should have a traditional Right of Decision, which could be practically applied as follows:

- a. The Conference always should be able to decide which matters it will fully dispose of on its own responsibility and which questions it will refer to the Al-Anon groups or, more usually, to their Area committee or GRs. Therefore, it ought to be clearly understood and agreed that our Conference Delegates are primarily the world servants of Al-Anon as a whole. Only in a secondary sense do they represent their respective areas. Consequently they should, on final decisions, be entitled to

cast their votes in the World Service Conference according to the dictates of their own judgment and conscience.

- b. Similarly the World Service Board of Trustees (operating of course within the provisions of its own Bylaws) should have the right, at all times, to decide when it will act fully on its own responsibility and when it will ask the Conference for guidance, approval of a recommendation, or actual direction.
- c. Within the scope of their defined or implied responsibilities, the headquarters corporation, its committees, staff, or executives should each have the right to decide when to act wholly on their own and when to refer a problem to the next higher authority.

This Right of Decision should never be an excuse for failing to render proper reports of all significant actions taken or used as a reason for exceeding a clearly defined authority, or for repeated failure to consult those who are entitled to be consulted before an important decision or action is taken.

Our entire Al-Anon program rests squarely on the principle of mutual trust. We trust God, we trust Al-Anon, and we trust one another. Therefore we cannot do less than trust our leaders in service. The Right of Decision we offer them is the practical means by which they may act and lead effectively; it also is the symbol of our implicit confidence.

## Concept Four

### ***Participation is the key to harmony.***

The Principle of Participation has been built into our whole service structure. If all authority were to be assigned to one group and virtually all responsibility to another, we would seriously handicap efficiency of operation and real harmony.

The Conference Charter specifically provides that the Trustees of our service corporation, Al-Anon Family Group Headquarters, Inc. shall always be voting members of the World Service Conference and further, leaves the door open for other Headquarters members as they may be needed.

As indicated in Concept Three, if the groups, sensing their great power, should try to overexercise it by directing their Delegates how to vote at the Conference, those Delegates would feel they were neither participants nor trusted servants. If, in turn, the Delegates

overexercise their power, they could make the Trustees mere rubber stamps.

Though it may seem inconsistent for service workers and Trustees to participate in voting on reports of their own activities, these reports constitute only a fraction of the business of the Conference, which is far more concerned with policies, plans, and actions to take effect in the future. The Conference needs the votes of such knowledgeable people as the Trustees and other members of Headquarters.

Since our Conference, unlike the U.S. Congress, cannot be constantly in session, there is good reason not to give Delegates absolute voting authority over Trustees, staff members, and Committee Chairpersons. They meet for a few days only, once a year, and cannot have firsthand knowledge of many problems on which they are expected to vote. This is all the more reason for allowing the often better-informed minority of Trustees and Headquarters people the privilege of balloting.

Some Delegates may object that, on close votes in the Conference, the combined ballots of the Trustees and service workers may decide a particular question. But their greater familiarity through experience fully justifies this. It should also be noted that they are not likely to vote in a bloc. Differences of opinion among them may be as sharp and considerable as those to be found among the Delegates.

The same concept is borne in mind when our Board of Trustees elects a Chairperson and members of the Executive Committee. If it wished, the Board could appoint its own members to most of these positions, but this, of course, is not done, because it would nullify the Principle of Participation.

The active management of the World Service Office, previously called the Headquarters Office, is vested in the Executive Committee, whose duty is to see that all projects are carefully carried out. The Executive Committee is composed of the Treasurer and the Executive Director, [4] both of whom are trustees; three members-at-large, who contribute their advice and professional experience; [5] a person from the administrative staff of the World Service Office; and the chairperson of the Policy Committee. For timely communication linkage, a member of the *Forum* Editorial and/or the *Forum* Business Operations Committee may be invited to attend Executive Committee meetings without vote. [6]



Whenever the Chairperson of the Board of Trustees appoints a Chairperson to the standing committees, he considers the same Principle of Participation. Trustees or non-Trustee volunteers comprise these committees, which have staff administrators [7] to do much of the detail work.

These arrangements permit a proper degree of voting participation. No class is set in absolute authority over another. Thus, in the participating method of doing business, there are no superiors and no inferiors, as distinguished from the institutional, military, or governmental method.

However, other than the Executive Director, no paid staff worker should become a Trustee. First, it would interfere with the rotation of the Board, which already has one nonrotating member. Second, if ever the headquarters corporation had to be reorganized by the Conference, paid Trustees in a bloc might prove a vested interest difficult to dislodge. [8]

Our Trustees may, however, invite paid staff members, accountants, and any others whose reports or advice may be required, to attend quarterly meetings of the Board, where they would have voice but no vote. When staff members are thus placed in direct communication with the Trustees, they realize they are wanted and needed.

Perhaps new generations of Delegates or Trustees may wish to weaken, modify, or eliminate the Principle of Participation. Occasionally a few Delegates may question the right of the Executive Committee, the staff, and even the Trustees to vote in the Conference. New volunteer members of the Executive Committee may ask why any paid staff members should be on this business management committee. Every now and then a move may be made to abolish the Executive Committee as a separate entity so that the Trustees could manage the office directly. But the Right of Participation in our service structure is of such high importance to our future that it is urged we preserve this traditional right in the face of every attempt to whittle it down.

Participation also responds to our spiritual needs. All of us deeply desire to belong. The Al-Anon ideal of a working partnership could never regard any member as second class. This is perhaps the main reason we have struggled to achieve participation at every level. The Right of Participation encourages us who serve Al-Anon to accept the necessary disciplines that our various tasks require. It assures

us that we are truly the “trusted servants” described in Al-Anon’s Tradition Two.

## Concept Five

### ***The rights of appeal and petition protect minorities and assure that they be heard.***

The Rights of Appeal and Petition aim to protect and make the best possible use of minority feeling and opinion.

In the principle of the Right of Appeal, all minorities—whether among our staff, Executive Committee, standing committees, Trustees—should be encouraged to file minority reports whenever they feel a majority to be in considerable error. Furthermore, when a minority considers an issue to be so grave that a mistaken decision could seriously affect Al-Anon as a whole, it has the actual duty of presenting a minority report to the Conference

This traditional Right of Appeal acknowledges that minorities can be right; that even when they are *partly* or wholly in error, they still perform a valuable service when by asserting their Right of Appeal they compel a thorough debate on important issues. The well-heard minority, therefore, is our chief protection against an uninformed, misinformed, hasty, or angry majority.

The traditional Right of Petition permits any person in our service structure; whether paid or unpaid, to petition for the redress of a personal grievance, carrying his complaint, if he desires, directly to the Board of Trustees. He should be able to do this without prejudice or fear of reprisal. Though in practice this right will be seldom exercised, its very existence will tend to restrain those in authority from unjust use of power. Surely our workers cheerfully accept the direction and discipline that go with their jobs, but all should nevertheless be confident that they need not silently endure unnecessary and unfair personal domination.

In our Al-Anon groups, individual freedom is of enormous importance. Anyone who feels his/her personal life is, or has been, deeply affected by close contact with a problem drinker is eligible for membership in Al-Anon. [9] We never take away this right to belong. Neither do we compel our members to believe anything or pay anything.

In our world services, we also go to great lengths in our trust of minorities. Under Tradition Two, the *group conscience* is the final

authority for Al-Anon world services. Nevertheless, the groups have recognized that for world service purpose our group conscience has certain limitations. It cannot act directly in many service matters, because it is seldom sufficiently informed about the problems at hand. During times of stress, it may not be the best possible guide, because emotional bias may prevent it, temporarily, from functioning efficiently or wisely. When, therefore, the group conscience cannot act directly, who does act for it?

We trust our servants, knowing that in the unusual event that they fail in their responsibilities, we still have ample opportunity to recall and replace them.

As trusted servants, our Al-Anon leaders must always be in readiness to do for the groups what the groups obviously cannot do for themselves. Consequently our servants are bound to use their own information and judgment, sometimes to the point of disagreeing with uninformed or biased group opinion.

The foregoing observations illustrate Al-Anon's concern for the freedom and protection of individual members and the whole membership's willingness to trust able and conscientious servants to function for us all.

Our Conference Charter is infused with provisions that ensure protection and respect for minorities. This is exemplified, for instance, in the method of selecting Delegates. Unless the majority candidate can poll a two-thirds vote of his state or provincial Assembly, he places his name in a hat with one or more of the choices of the Assembly minority. By thus drawing lots, the minority candidates have an equal chance with the majority's choice.

This method of electing Delegates strengthens the spirit of democracy among us. Unity is cemented, cooperation increased, and when the Delegate is finally chosen, the minority has no reason for discontent. To increase the actual spirit of democracy by special deference to minority opinion is better than to follow blindly the rule that insists in unqualified dominance by majority vote.

Consider another example: Our respect for the minority position plus a desire for unity and certainty often prompt the World Service Conference to debate important questions of policy even in cases where a majority could easily be obtained. Such a voluntary practice is evidence of real prudence and courteous deference to the views of all. The Conference usually makes important decisions on no less than a two-thirds vote.

This same consideration for the minority position can be found in the Charter provision that no Conference vote can be considered binding on the Board of Trustees unless it equals two-thirds of a Conference quorum. Up to this point, the Trustees have a power of veto. They may ask for further debate to check any tendency to haste or emotionalism. They may choose to veto a simple majority or to act with it. Here again is recognition of the constructive value of a trusted minority.

If to such ample recognition of minority privileges we now add the traditional Rights of Appeal and Petition, we shall have granted to all minorities, whether of groups or of individuals, the means of discharging their world service duties confidently, harmoniously, and well.

In Al-Anon, we believe the spirit of democracy in our fellowship and in our world service structure will always survive despite any countertendencies that may beset us.

We believe that we shall never be subjected to the tyranny of either majority or minority, provided we carefully define the relationship between them. We can then tread the path of world service in the spirit of our Twelve Steps, our Twelve Traditions, and these Concepts.

## **Concept Six**

### ***The Conference acknowledges the primary administrative responsibility of the Trustees.***

Just as the Al-Anon groups can act decisively in world service affairs only by entrusting authority and responsibility to their Conference, so must the Conference in turn entrust administrative authority to Al-Anon Family Group Headquarters, Inc., in order that its Trustees may act freely and effectively in the absence of the Conference.

For several important reasons, the Trustees must have freedom to act. Next to the Conference, Al-Anon's Board of Trustees should be our most influential group of world servants. We shall have to consider carefully the kind and degree of authority, responsibility, leadership, and legal status the Trustees must possess in order to function at top effectiveness in the years to come. We shall need to define clearly the kinds of professional and financial skills that

will be required for a balanced Trusteeship. Thus we permanently ensure the Board's capability of future leadership.

It will also be necessary to show precisely how the Trustees ought to be related to the Conference and, in turn, to the Executive Committee and any other active service committees or corporations that may be needed in the future. In a general way these relations already are indicated in our Conference Charter and on preceding pages. There still remains a need to interpret them in detail. These relations should never be frozen into a rigid pattern. However satisfactory and right our present arrangements are, the future may require changes that we do not yet envision. New conditions may require refinements or even considerable alterations. For this reason our Charter is capable of being readily amended by the Conference itself.

If later we do make changes that happen to work out poorly, the experience of the past will provide, in these articles, a point of safe return to tested procedure.

A careful review of the legal and traditional rights of the World Service Board of Trustees clearly indicates their actual administrative responsibilities. Their authority in this field is unquestionably great.

Why should our Trustees be given this wide latitude of judgment and action? The answer is that they are held chiefly responsible for all our service activities, as well as for Al-Anon's worldwide public relations. They are expected to spearhead the formulation of Al-Anon policy and its proper execution. They are the active guardians of our Twelve Traditions. The Trustees have ultimate responsibility for the preservation and prudent management of all Al-Anon's financial assets. They are accountable for the internal controls of funds received and the investment thereof. [10] The wide range of their activities is further detailed under Concept Eleven.

While the Trustees must operate under the close observation, guidance, and sometimes the direction of the Conference, it is nevertheless true that only the Trustees can evaluate and handle most of the innumerable transactions involved in our World Service operation. In view of this great responsibility, they must be given a correspondingly large grant of authority and leadership with which to discharge it. It must be understood that the conduct of our World Services is primarily a matter of policy and business. While our objectives are spiritual, these aims can be achieved only by means

of an effective business operation. Since our Trustees must function like the directors of any large business corporation, they must have ample authority to manage and conduct Al-Anon's business.

## Concept Seven

### **The Trustees have legal rights while the rights of the Conference are traditional.**

At first this Concept may appear contradictory. Actually both the rights of the Trustees and the Conference work well together. On the one hand, we see a Board of Trustees invested with complete legal power over Al-Anon's funds and services; on the other hand, Al-Anon's World Service Conference has such great responsibility for and authority over all aspects of Al-Anon's program and policies that in those areas it could give the Trustees directives and secure their compliance. [11]

This means that the actual power of the Conference will nearly always be superior to the legal power of the Trustees since it flows from the powerful traditional influence of the Charter itself. It derives from the large majority of group-chosen Delegates in the Conference. And finally, in any great extremity, it would rest upon the unquestioned right of the Delegates to deny Al-Anon Family Group Headquarters, Inc., the moneys with which to operate—those voluntary contributions of the Al-Anon groups themselves. Theoretically, the Conference is an advisory body; practically speaking, it has the ultimate rights and powers.

The Board of Trustees is not likely to contest the clear and sustained will of the Conference Delegates and the Al-Anon Areas they represent. [12] If someday a crucial stalemate arose between the Delegates and Trustees, the Conference, as the conscience of Al-Anon, would find itself in complete authority over the Al-Anon Family Group Headquarters, Inc, and its arms of active World Service.

Experience shows that this balance of powers between the Trustees and the Conference is thoroughly workable. We believe this balance can be maintained indefinitely, because the one is protected by tradition and the other by law.

An interesting question often raised by new Trustees is whether they haven't a legal right to say no to something the Conference wants.

In certain corporate business areas, the Trustees certainly do have this legal authority; but on the other hand, they are quite at liberty to accept, even seek, advice and recommended directions from qualified sources. [13] Just as the Conference should avoid the overuse of its traditional authority, so should the Trustees avoid overuse of their legal authority.

Clearly, then, our Board of Trustees does reserve a veto power over any Conference action; this is legally necessary and right in principle, even though the veto will seldom be used. At certain times, however, the Trustees' veto could be of important and constructive use.

Here, for instance, are three typical examples in which it would be the duty of the Trustees to veto Conference action:

1. If, in a time of haste or heavy stress, the Conference should take an action or issue a directive to the Trustees in clear violation of the its own Charter or of the Bylaws of the headquarters corporation, or if the Conference were to pass any measure so ill-considered or so reckless as to seriously injure, in the judgment of the Trustees, Al-Anon's public relations, or Al-Anon as a whole, it would then be the duty of the Trustees to ask for Conference reconsideration. In the event of a Conference refusal to reconsider, the Trustees could then use their legal right to veto. If desirable, they could appeal the issue directly to the Al-Anon groups themselves.
2. Although traditionally the Trustees never should substantially exceed a Conference approved budget without consulting the Conference, they should feel entirely free to reduce this budget figure during any fiscal year, even though such an action might curtail or cancel plans or projects initiated and directed by the Conference itself.
3. If, by reason of unforeseen conditions, any particular plan, project, or directive of the Conference should become impractical **or** unworkable during a fiscal year, the Trustees should, without prejudice, be able to use their right of veto and cancellation.

In the years ahead, the Conference should always bear in mind the actual rights, duties, responsibilities, and legal status of the Board of Trustees; the Trustees should constantly realize that the Conference is the real seat of ultimate service authority. Then we may be sure that neither will be seriously tempted to make a rubber

stamp of the other. In this way, grave issues can always be resolved by harmonious cooperation.

## Concept Eight

***The Board of Trustees delegates full authority for routine management of Al-Anon Headquarters to its executive committees.***

The Trustees of the Al-Anon Family Group Headquarters act in two major capacities: (a) in matters of policy and finance, they are the principal planners and are responsible for final decisions; (b) in routine operations, the Trustees delegate full authority to executive committees charged with the management of Headquarters.

To arrive at this Concept, experience has led us through the following stages of development:

From 1951 to 1954, when Al-Anon's Headquarters was still trying to feel its way, the workers at the then-named Clearing House were advised by a committee of representatives of neighboring Al-Anon groups who could occasionally meet informally. After the incorporation of Headquarters late in 1954, its Board of Trustees administered the World Service Office. Seven to eleven in number and meeting monthly, the Trustees appointed a large committee of volunteers to advise them. This Advisory Committee included all the Trustees and convened every three months. Any recommendations or resolutions proposed by the Advisory Committee had to be ratified by the Board of Trustees.

In 1957, the Advisory Committee was further formalized by a Charter and given a new name—the Advisory Board. It was the authorized custodian of overall Al-Anon policy and finance. In the Charter the hope was expressed that a permanent conference of delegates from the various states and provinces would eventually take the place of the Advisory Board. The day-to-day administration of the office, however, was still in the hands of the Trustees. (The latter, by the way, were known as “Directors” from March 1957 to January 1965.)

After three years' trial, in 1964, the World Service Conference did come into being as the permanent guardian of Al-Anon's Traditions and services, replacing the Advisory Board, which held its last meeting on November 11 of that year.

By this time, however, the business of Al-Anon's headquarters had grown so large that it became unwieldy for the Board of Trust-



ees to handle the routine administration of the office. Our Trustees realized they could no longer be concerned as a body with the endless details that arose daily, weekly, monthly in the routine conduct of the World Service Office. They also realized the need to devote themselves to the more serious questions of policy, leadership, finance, group and public relations.

Therefore, the Board decided to assign its administrative function to a more constantly available seven-member Executive Committee, possessing the Board's full legal powers and composed of three elected Al-Anon members—preferably not Trustees—the Executive Director [14], a person [15] from the administrative staff of the World Service Office, and the Chairpersons of both the Budget and Policy Committees. The Chairperson of this Executive Committee is elected by the Board of Trustees.

The Board's position thus became that of custodian and guarantor of good management of Al-Anon's World Service Office.

*The Forum*, from its inception, had a single editor with the full responsibility for choice of material, layout and the writing of editorials. As our magazine grew, an Editorial Committee was appointed by the Trustees in 1968 to assist the Editor. If and when the magazine reaches the stage where it should handle its own subscriptions and printing, a Forum Executive Committee will no doubt be needed. This would make the World Service Office and *The Forum* two separate operations, each with its own Executive Committee and each with separate funds and facilities.

There is always a strong connection between money and authority. This is a potent reason for forming separate entities for the management of these two dissimilar services.

The Board of Trustees would, of course, maintain its custodial supervision of both operations through its prerogative to elect the Executive Committee for both entities.

## Concept Nine

***Good personal leadership at all service levels is a necessity. In the field of World Service the Board of Trustees assumes the primary leadership.***

No matter how carefully we design our service structure of principles and relationships, no matter how well we apportion authority

and responsibility, the operating results of our structure can be no better than the personal performance of those who man it and make it work. Good leadership cannot function well in a poorly designed structure. Weak leadership can hardly function at all, even in the best of structures.

Good leadership can be here today and gone tomorrow. Furnishing our service structure with able and willing workers is a continuing activity. We must constantly find the right people for our many service tasks. Since our future effectiveness thus depends upon ever-new generations of leaders, it seems desirable that we now define what a good service leader should be; that we carefully indicate for each level of service (especially for our Board of Trustees) what special skills will be required; that we review our present methods of finding and choosing leadership.

First let's remember that our service structure rests on the dedication and ability of thousands of Group Representatives (GRs), District Representatives, and Delegates. These are the direct agents of the Al-Anon groups; these are the indispensable links between our fellowship and its world service; these are the primary representatives of Al-Anon's group conscience.

When choosing GRs, Al-Anon groups should therefore bear such facts well in mind. It is only the GRs who, in district or Assembly meetings, can name District Representatives and finally name the Delegate. Hence, great care needs to be taken in choosing these representatives. Hit-or-miss methods should be avoided. Groups without GRs should be encouraged to elect them. Improvement in this field is a matter of increased care, responsibility, and education.

As the GRs meet in their Assemblies to name a Delegate, an even greater degree of care and dedication will be required. Personal ambitions must be set aside, antagonisms and controversy forgotten. "Who are the best qualified people we can name?" should be the sole thought.

The Handbook or Third Legacy method of naming Delegates by a two-thirds vote or by lot greatly reduces political friction; it makes each Delegate feel that he or she is truly a world servant rather than merely the winner of a contest. Thus far, our Third Legacy methods have produced District Representatives and Delegates of a high level of dedication and competence. Our Area Assemblies need only to continue to act with care and in a selfless spirit.

Some members, still doubtful whether choice by lot is a good idea, feel that the best person does not always win. It must be pointed out that each time we have disregarded the two-thirds vote or lot in naming Delegates, there has been a sense of defeat and disturbance in the minority camp, which is not offset by naming the supposedly best person. Indeed the second-best person can often be as good a Delegate as the Assembly's first choice and may even be a better Delegate.

Let us now consider the specific personal qualities a World Service leader ought to have. The following slightly modified essay, "Leadership," written by Bill W. for a 1959 issue of the *A.A. Grapevine*, applies equally well to Al-Anon.

No society can function well without able leadership at all levels, and we are no exception. However, we sometimes warp the traditional idea of "principles before personalities" to such a point that there would be no personality in leadership whatever. This would imply rather faceless automatons trying to please everybody.

At other times, we may demand that our leaders be people of the most sterling judgment, morals, and inspiration.

Real leadership, of course, has to function in between these entirely imaginary poles. In our fellowship certainly no leader is faceless, nor is any leader perfect. Fortunately we are blessed with any number of real leaders—those men and women whose dedication, stability, vision, and special skills make them capable of dealing with every possible assignment. We have only to seek these folks out and trust them to serve us.

A leader is a person who can put principles, plans, and policies into such dedicated and effective action that the rest of us want to back him up and help him with his job. When a leader is a power-driver, we rebel; when he is just an order-taker and exercises no judgment of his own, he isn't a leader at all.

▶ A good leader originates plans and policies for the improvement of our fellowship. In new and important matters, he nevertheless consults widely before making decisions. Good leadership knows that a fine plan or

idea can come from anyone, anywhere. Consequently, good leadership often discards its own cherished plans for those that are better, giving credit to the source.

Good leadership never passes the buck. Once assured of sufficient backing, it freely makes decisions and puts them into action, provided of course that such actions be within the framework of its defined authority and responsibility. A “politico” is an individual who is forever trying to “get the people what they want.” A statesman is an individual who can carefully discriminate when and *when not* to do this. He recognizes that even large majorities, when badly disturbed or uninformed, can be dead wrong. When such an occasion arises with vital matters at stake, it is the duty of leadership to take a stand against the storm, using its every ability of authority and persuasion to effect a change.

Nothing, however, can be more hampering to good leadership than opposition for opposition’s sake alone. “Let’s have it our way or no way at all” is often powered by visionless pride or a gripe. The opposition that casts its vote “no” without giving any real reasons won’t do either. Leadership should always have good reasons and give them.

Then, too, a leader must realize that even very prideful or angry people can sometimes be right, when the calm and the more humble are quite mistaken.

Another qualification for leadership is “give and take,” the ability to compromise cheerfully whenever it can cause a situation to progress in what appears to be the right direction. Compromise comes hard to many of us. Nevertheless, progress is nearly always characterized by a *series of improving compromises*. We cannot, however, always compromise. Now and then, it is necessary to stick flat-footed to one’s conviction. Careful discrimination and keen timing are required in all situations.

Leadership is often called upon to face heavy and sometimes long-continued criticism—an acid test. There are always constructive critics, our friends indeed. We ought never fail to give them a careful

hearing. We should be willing to let them modify our opinions or change them completely. Often, too, we shall have to disagree and then stand fast without losing their friendship.

Then there are destructive critics. They power-drive, they are “politicos,” they make accusations. Maybe they are violent, malicious. They spread rumors and gossip to gain their ends—all for the good of the fellowship! We have to learn that these people, who may be a trifle sicker than the rest of us, need not be destructive at all, depending on how we relate ourselves to them.

If we are the target, we ought to listen carefully to what they say. Sometimes they are telling the whole truth; at other times, a little truth. More often, though, they are just rationalizing themselves into nonsense. If they speak even a little truth, we had better thank them, take our respective inventories, and admit we were wrong. If it is nonsense, we can ignore it or lay all the cards on the table and try to persuade them. Failing this, we can be sorry they are too sick to listen and try to forget the whole business. There are few better means of self-survey and of developing genuine patience than the workouts these usually well-meaning erratic members afford us. This is a large order and sometimes we shall fail to make good on it, but we must keep trying.

Now we come to the all-important attribute of vision. Vision is, I think, the ability to make good estimates, both for the immediate and for the more distant future. Some might feel this to be heresy. But the valuable principle of “one day at a time” really refers to our mental and emotional lives and means that we are not to repine over the past nor daydream about the future.

As individuals and as a fellowship, we shall surely suffer if we cast the job of planning for tomorrow onto a fatuous idea of Providence. God has endowed human beings with considerable capability for foresight and evidently expects us to use it. Therefore, we must distinguish between wishful fantasy and thoughtful estimate. This can spell the difference between future progress and unforeseen woe.

Of course we shall often miscalculate the future in whole or in part, but that is better than to refuse to think about it at all. The making of estimates has several aspects. We look at past and present experience to see what we think it means. From this we derive a tentative idea or policy. First, we ask how this idea or policy might work in the near future. Then we ask how it might apply under differing conditions in the longer future. If an idea seems good, we try it experimentally, when that is possible. Later, we evaluate the situation and ask whether our estimate is working well.

At this stage, we may have to make a critical decision. Maybe our policy or plan still looks fine and is apparently doing well. Nevertheless, we ought to ponder carefully its longtime effect. Will today's advantages boomerang into liabilities for tomorrow? The temptation might be to seize the immediate benefits and forget the harmful precedents or consequences that might result.

We have found we must use these principles to estimate constantly, especially at World Service levels, where stakes are high. We must think about our service needs as they relate to general economic conditions, group capability, and willingness to contribute. We often must try to think months and years ahead.

Such is the process of estimating the future. Responsible world leadership must be proficient in this vital activity. It is an essential ability, especially in our Trustees. Most of them should be chosen on the basis that they have already demonstrated foresight in their activities for the fellowship and in their own careers.

Thank God that so many of our service leaders at all levels of operation are blessed with the attributes of tolerance, responsibility, flexibility and vision.

## Concept Ten

***Service responsibility is balanced by carefully defined service authority and double-headed management is avoided.***

The guarantee of harmonious and effective function of good operational structure is in the relation of its several parts and people, so that none can doubt the nature of their respective responsibilities and corresponding areas of authority. Unless these relationships are well-defined and those holding the final authority are able and willing to delegate suitable operational authority; unless those holding such authority feel able and willing to use it freely as trusted servants; and unless there exists some definite means of interpreting and deciding doubtful situations—then personal clashes, confusion, and ineffectiveness will be inevitable.

The matter of responsibility and its necessary and co-equal authority is of such urgent importance that it might be profitable to recapitulate what has already been said, meanwhile taking a bird's-eye view of our entire structure to better envision how this principle does, and always must, apply in our every activity and attitude.

The first characteristic that any working structure must have is a point, or succession of points, where there is ultimate responsibility and ultimate authority. We have already seen how, for Al-Anon's world service, this kind of final responsibility and authority resides in the Al-Anon groups themselves. And they, in turn, have entrusted some of their ultimate authority to the Conference and the Trustees.

We have observed how the Conference Delegates, directly representing the groups, are actually in a position of ultimate authority over the Trustees. We have seen further how the Trustees are in ultimate authority over the standing and Executive Committees of the World Service Office and the Al-Anon *Forum*. The principle of ultimate authority runs through our entire structure. This is necessary, because all our service affairs and activities must be directed at the point at which final responsibility rests, so that each worker, or each class of workers, knows who makes final decisions.

If, however, authority is not specifically delegated, we would have the opposite result: The groups could direct their Delegates on every important issue; the Delegates could similarly turn the Trustees into a spineless committee to be given specific direction on almost every matter; likewise, the Trustees could regard themselves as the sole directors of the service entities, making automatons of the working staff. In short, such a misuse of ultimate authority would add up to a dictatorship in which nearly every classification of Al-Anon servants would have large responsibilities but no definite authority, and

hence no capability of effective decision and leadership. Big or little tyrannies and buck-passing would be the inevitable consequence.

Therefore, it is clear that ultimate authority is not something to be used indiscriminately. Indeed, ultimate authority should practically never be used in full, *except in an emergency*. That *emergency* usually arises when delegated authority has erred, when it must be reorganized because it is ineffective, or because it constantly exceeds its defined scope and purpose. For example, if the groups are dissatisfied with the Conference, they can elect better Delegates or withhold funds. If the Delegates must, they can censure, and under certain circumstances, they can bring about the reorganization of the Board of Trustees. [16] The Trustees can do the same with the service committees.

These are the *proper* uses of *ultimate authority*, because they correctly discharge an ultimate responsibility. The *influence* of ultimate authority must always be felt, but it is perfectly clear that *when delegated authority is operating well, it should be left alone*. Otherwise those charged with operating responsibility will be demoralized, because their work will be subject to arbitrary invasion, and the demands made upon them would be greater than their authority.

Let us review the foregoing Concepts and note how, at each structure level, accurate definitions of authority and responsibility have been given. This has been done by (a) traditional means, (b) legal means, and (c) by principles under which doubtful or conflicting situations can be interpreted and resolved.

- a. Consider the Conference Charter. It is not a legal instrument, but practically speaking, it is substantially a contract between the Al-Anon groups and the Conference. The Charter indicates that the Al-Anon groups have delegated some of their ultimate authority and all-needed operational authority to the Conference. This includes the Trustees and the active services. It further suggests that each Conference member be entitled to cast his ballot according to the dictates of his own conscience; that the Conference itself also be granted, under the traditional Right of Decision, the privilege of choosing which matters it will decide and which it will refer back to the groups for their discussion, guidance, or direction. These are the traditional definitions designed to check the natural tendency of the groups to overinstruct Delegates. This gives the Conference an authority equal to its responsibility.



- b. Consider next the position of the Trustees. It has already been stated that although the Conference has the ultimate authority, the Trustees must have the legal right to actively administer our service affairs. Their legal right has been further strengthened and its use encouraged by the traditional Right of Decision. We recognize also that the Trustees have a legal right of veto over the Conference when, in rare cases, they feel it should be used. By these means we have guaranteed the Trustees administrative authority equal to their actual responsibility. The position of the Trustees is further strengthened by their voting participation in the Conference and by the recognition that they are Al-Anon's primary World Service administrators. All this, of course, does not deny in any way the ultimate authority of the Conference or of the Delegates, should it be necessary to give the Trustees directives or censures or to reorganize the Board.

Much care has also been taken to guarantee the Executive Committee an ample operating authority that fully matches its responsibility for the routine conduct of our active services. The same would be true of any later-formed committees or boards, such as a Forum Editorial Board. However, the legal authority of the Trustees over all of its subsidiary committees and boards is not only ultimate it is absolute the moment the Trustees have reason to make such a decision. They can name new committees or boards at any time; they control the budget and can withhold operating funds. Nevertheless, so long as things go well, it is highly important that the Trustees do not unnecessarily interfere with or usurp the operating authority of these entities. Hence the care taken in constructing these definitions of delegated authority.

To a considerable degree, the standing committees of the World Service Office—Policy, Budget, Public Information, [17] and the others—have a similar latitude. Under the principle of the Right of Decision, each primary committee may choose what business it will dispose of and what matters it will refer to the Trustees. The position of these committees is also fortified by the appointment of a generous proportion of non-Trustee members. Here, too, provision has been made to equalize the authority of these committees with their responsibility.

- c. Now we come to the matter of conflicting authority and how these conflicts are to be resolved. Most routine conflicts in the active services are easily settled, because ready communication has been provided between all service committees and boards.

In all matters of joint or conflicting authority, a primary jurisdiction must be established, an understood point or body where a final settlement can be reached. The secondary jurisdiction must also be heard. Minor conflicts will not need to be referred to the Trustees, but the *point of final decision is always located there*.

Suppose, for example, that one of the service departments develops plans for expansion. It first takes these plans to the Policy Committee. If the Policy Committee approves the plans, it recommends them to the Board of Trustees. However, if a considerable sum of money will be needed, the plans will first have to be submitted to the Executive Committee.

If, after consultation with the Budget Committee, the Executive Committee agrees that the expenditure is warranted and is in line with the overall budget, it makes its recommendation to the Trustees. But if the Executive Committee objects, it must then file its objection with the Trustees, who will settle the issue. If necessary the Trustees will refer the matter to the Conference.

Primary and secondary jurisdiction also works the other way around. If the Executive Committee after consulting the Budget Committee, for example, proposes a large expenditure that may strongly affect Al-Anon feeling and policy, it refers the matter to the Policy Committee. Then, after both the expenditure and the reason for it have been agreed on, it is recommended to the Board of Trustees for its final decision.

A condition to be avoided at all costs is *double-headed* business or policy management. Authority can never be divided into equal halves. Nowhere does such split authority so bedevil a structure as in its executive departments. The vital need to avoid double-headed executive management will be fully discussed under Concept Eleven.

In addition to the methods we use to make delegated authority equal to delegated responsibility, we have two more guarantees—the Right of Appeal and the Right of Petition. As mentioned in Concept Five, a bare majority may constitute a pseudo-ultimate authority on many occasions when it is not warranted. Likewise, executives may

over- boss their assistants. Therefore, we use the concepts of Appeal and Petition to ensure that every minority and every worker who does a job has an authority and a status commensurate with the responsibility involved.

To sum up: Let us always be sure that there is an abundance of final or ultimate authority to correct or to reorganize; but let us be equally sure that all of our trusted servants have a clearly defined and adequate authority to do their daily work and to discharge their clear responsibilities.

All of this is fully implied in Al-Anon's Tradition Two. Here we see the "group conscience" as the *ultimate* authority and the "trusted servant" as the *delegated* authority. One cannot function without the other. We well know that only by means of careful definitions and mutual respect can we constantly maintain a harmonious working balance.

## Concept Eleven

### ***The World Service Office is composed of standing committees, executives and staff members.***

While the Trustees hold final responsibility for Al-Anon's world service administration, they should always have the assistance of the best possible standing committees, executives, staff, and consultants. This means careful consideration of these committees, the personal qualifications of their members, the manner of their induction into service, the way in which they relate to each other, the special rights and duties of our executives, staff, and consultants, together with a proper basis for the financial compensation of our special workers.

The long-range success of our World Service Office will rest not only on the capabilities of the Trustees but also upon the competent leadership and harmonious association of those non-Trustee committee members, service directors, executives and staff members who actively carry on Al-Anon's world services. Their quality and dedication, or their lack of these characteristics, will make or break our structure of service. Our dependence on them will always be great.

Far more than most of the Trustees, these servants are in direct contact with Al-Anon worldwide through correspondence and travel. Their performance is constantly on view by visitors to the

WSO. They perform most of the routine tasks and carry on most of our services. They often initiate new plans and policies. Because this group is the visible image of world service, most Al-Anons evaluate our service by what they see and feel in them. These servants not only *support* the world leadership of the Trustees, they *share* world leadership with them.

With the approval of the Board of Trustees, its chairperson annually appoints committee Chairpersons and is himself, along with the Executive Director [18], ex-officio member of each committee. [19] The committee Chairpersons recruit their members, who are then approved by the Board. Staff members are represented on each committee. Conference Delegates also serve on a number of these committees.

The standing committees of the World Service Office include: \*

(1) Policy, (2) Alateen, (3) Budget, (4) Conference, (5) Institutions, (6) Literature, (7) Nominating, (8) Public Information, (9) Archives, (10) International Coordination, (11) Cooperating with the Professional Community, and (12) Regional Service Seminars. [20]

None of these service committees are executive in character. They do not manage or conduct the active affairs of the service departments. They may, however, make any recommendations they wish to the services themselves, to the Executive Committee or to the Trustees.

Let us look at each of these in turn.

**1. The Policy Committee:** This is perhaps the most important of all the World Service Office committees. It can take jurisdiction over practically all problems or projects that involve Al-Anon policy, public relations, or the Traditions, as these may arise in other committees.

The Policy Committee makes recommendations to the Board of Trustees and also reports minority views. In an emergency, when immediate action is necessary, its decision is binding so far as that particular incident is concerned. But this decision does not necessarily become part of the overall policy, unless approved by the Board of Trustees and the World Service Conference. *[See Appendix for A.A.'s General Policy Committee.]*

---

\* The 2002 Conference approved the new committee structure, which will be detailed in the next printing.

The Policy Committee is composed of a chairperson, all members of the Board of Trustees, at-large members of the Executive Committee, the chairpersons of all WSO committees, and the Conference members of the WSO administrative staff, and meets quarterly in advance of the Trustees meeting. [21] It is empowered to consider any problems or projects submitted by an Al-Anon member, or to reconsider a decision already made if dissented from by any part of the fellowship.

2. **Alateen Committee:** This committee correlates the activities of Alateens on a national level. [22] It was formed in 1959, when the teenage sons and daughters of alcoholics indicated the need by asking the World Service Office if they could have their own Steps and Traditions. Up to this time a junior fellowship within Al-Anon had not been envisioned. With help from the WSO, the teenagers themselves adopted the Al-Anon Steps and adapted the Traditions to their own use.

The Alateen fellowship has unique problems, which need thoughtful consideration from many angles. Finding sponsors is one of the more difficult problems. Many Al-Anon members who have the time and capability are not interested in sponsoring an Alateen group. A.A.s are far more willing to do so; but one of Al-Anon's provisions for Alateen is that an Alateen group should have an Al-Anon sponsor whether or not *he or she is assisted* [23] by an A.A.. A valuable source of Alateen sponsorship should be Al-Anon members who were formerly Alateens.

Another of the unique problems is that, in the nature of things, Alateen membership is exceptionally fluid. There are no longtime members with a backlog of experience to give stability to the groups or to plan for Alateen's future. Youngsters grow up, go to college, get married, move away, join Al-Anon. They are teenagers, at most, for seven years. Therefore, since Alateen is part of Al-Anon, Al-Anon must make those provisions that Alateen cannot make for itself.

3. **The Budget Committee:** The main responsibility of this body is to see that we remain solvent without making a god of money. Here money and spirituality *do* have to mix, and in just the right proportion. Here we need hardheaded members with financial experience. All should be realists, and a

pessimist or two can be useful. The whole temper of today's world is to spend more than it has or may ever have. When a new and promising Al-Anon service project moves into sight, we may cry, "Never mind the money, let's go at it." This is when our budgeters are expected to say, "Stop, look, and listen." This is the exact point where the "savers" come into a constructive and healthy collision with the "spenders." The primary function of this committee, therefore, is to see that our WSO operation is always solvent and that it stays that way, in good times and bad.

This committee conservatively estimates each year's income. It develops plans for increasing our revenues, keeps a watchful eye on expenditure, and avoids waste and duplication. It closely scrutinizes the yearly budgets of estimated income and expense submitted by the World Service Office, including *The Forum*. It suggests amendments of the estimates when necessary. At mid-year it asks for budget revisions if earlier estimates have been inaccurate. It considers every new expenditure in the light of "Is this necessary or desirable now? Can we afford it?"

When appropriate the Budget Committee recommends that the Board of Trustees set aside sums in our Reserve Fund with the assurance of the immediate availability of those funds. [24] This should enable us to meet hard times or even a calamity.

This is not to say that our Budget Committee should be negative and fearfully hoard our money at the expense of office services and needed help to cope with our phenomenal growth. Penny-pinching could affect our services and deprive us of the confidence of our groups. Such false and unimaginative economy could prove very costly—in spirit, in service, and in money.

Real prudence is neither hoarding nor recklessness. We may occasionally be compelled to risk temporary deficits, but uncontrolled spending could result in the severe curtailment or collapse of our vital services, and should be guarded against with great care.

4. **The Conference Committee:** Although the Conference is in session for less than a week in April, the multitudinous details of making arrangements for it beforehand and of reporting it

afterward is an all-year-round undertaking. As soon as possible after the close of the Conference, the Delegates and the groups receive an extensive Summary of the Conference sessions, including the reports of all committees.

Since the Conference is the most effective means of communication between the WSO and the North American groups, this committee has the responsibility of preparing a program that will be as informative as possible—giving the Delegates an opportunity to present the needs of the groups to the WSO and a chance to reveal the extent and breadth of the work of the world headquarters to the groups through their Delegates. [25]

- 5. Institutions Committee:** This committee develops and communicates methods members can use to bring the Al-Anon and Alateen presence to the families and friends of alcoholics who are in hospitals, treatment centers, correctional and other residential facilities. It also seeks to help members differentiate between the Al-Anon philosophy of recovery and that of the treatment center approach. Such clarification helps to uphold our Traditions, thus avoiding dilution of the Al-Anon program.

Soon after Al-Anon Family Group Headquarters was formed, A.A. encouraged Al-Anon to contact the families of patients, inmates and residents requesting help. This resulted in a beneficial correspondence with many of these A.A. families carried on by one of our early volunteers. Later, the work lagged for several years for lack of an available interested volunteer chairperson, until 1967, when an Institutions Committee formed with a permanent staff administrator.

Although we took our early lead in developing service work within institutions from A.A., it later became apparent that a different approach was needed, since there are more alcoholics confined to institutions, whereas the families are usually the visitors.

Great care is taken to preserve anonymity while aiding the family or friends to contact an Al-Anon or Alateen home group. As this A.A. member bears the stigma of being an alcoholic and an inmate or resident, the family may be relieved to find that alcoholism is a disease and the effects of alcoholism are often a contributory cause of the relative or friend being

confined to a hospital, treatment center, correctional or other residential facility. [26]

6. **The Literature Committee:** This body [27] is charged with the revision of existing books and pamphlets and with the creation of fresh material to meet new needs or changing conditions. Broadly speaking, its mission is to see that every aspect of the Al-Anon program of recovery is presented in adequate and comprehensive written material for our members, friends and the world at large. [28] Our literature is a principal means by which Al-Anon growth, unity and service are facilitated. The influence of the many thousand books and pamphlets shipped each year is incalculable. To keep our literature fully abreast of our progress is therefore urgent and vital.

The Literature Committee often has to solve new problems of design, format, and content. Here, our policy is to aim at only the best; we firmly believe that cheap-looking, cheap-selling, and poorly conceived literature is not in Al-Anon's best interest.

Like other WSO committees, this one must be expert in the work to be done. The initial form and draft and the final development of new undertakings is the responsibility of this committee, whose members exercise their role as constructive critics of evolving recovery material. [29] Here, too, the committee includes persons of wide Al-Anon experience. It is absolutely vital to get the "Al-Anon feel" into all our writings. What we say so well by word-of-mouth we must also communicate in print.

The Literature Committee carefully tests each new production by asking for the reactions and suggestions of a number of other members who are sensitive to the Al-Anon idea and feeling. Originally, this committee was responsible for all Conference Approved Literature (CAL). As Al-Anon grew so did the scope and expertise of its service area and consequently the variety and amount of all CAL. In order to maintain the high quality of Al-Anon literature, the World Service Conference (WSC) in 1985 voted to assign responsibility for service literature to the appropriate service committees. All Al-Anon material, whether recovery or service oriented, must follow the Conference approval process. [30]



- 7. Nominating Committee:** At first Al-Anon's Nominating Committee was a temporary one, operating only sufficiently ahead of the annual meeting of the Board of Trustees to present a slate of officers. This was primarily because the choice of members available for the Board was limited. Later, when there were more members, the value of a permanent committee was recognized and one was formed.

This committee aids the Trustees in discharging their prime obligation to see that all vacancies—whether within their own ranks or among key service executives and chairpersons—are properly filled with those of the greatest possible competence, stability, and industry.

The Nominating Committee, after having consulted with the Conference Committee on Trustees, will make recommendations that will determine, to a large extent, the continuous success of our services. Its members will have the primary voice in choosing our future Trustees-at-large and at-large members of the Executive Committee. Careful deliberation, painstaking investigation, refusal to accept casual recommendations, advance preparation of lists of suitable candidates—these need to be the principal attitudes and activities of this committee. [31]

- 8. The Public Information Committee:** This committee [32] is important because it is the liaison with the public. Although most of its members should be experienced in the field of public relations, commercial expertise is not enough. Al-Anon's conservatism, as reflected in the Tradition "Attraction rather than promotion," requires the professional members of the committee to adapt their business experience to Al-Anon's needs. The techniques used to sell a TV personality or a new cosmetic would not be for Al-Anon. The committee should always include some members who, because of long experience, have "Al-Anon sense," that is, a thorough grasp of our total picture and our relation to the public.

Nevertheless, we need high professional skill to deal with the huge complex of public communications as it exists today. This is not a job for amateurs alone. It takes technical experience, diplomacy, a sense of what is hazardous and what is not, the courage to take calculated risks, and a readiness to make

wise compromises that abide by our Traditions. This is the combination of talents we shall always need.

We are trying, both directly and indirectly, to reach more of the families of those 25 million alcoholics who today inhabit the world. In order to accomplish this, it will be necessary to provide knowledge and to generate public goodwill toward Al-Anon everywhere. [33] We need the increasing goodwill of editors, writers, television and radio. These publicity outlets—local, national and international—should be opened wider and wider, but never by means of high-pressure tactics. It is to, and through, all these resources that we must try to carry Al-Anon's message to those who suffer the consequences of alcoholism.

The work of our Public Information Committee [34] is a critical assignment; a single large public blunder could cost many lives and cause much suffering by turning new prospects away. Conversely, every real public information [35] success attracts the families of alcoholics to Al-Anon.

- 9. Archives Committee:** This committee is concerned with preserving and organizing historical Al-Anon/Alateen material, past and current.

It acts in an advisory capacity to the archivist, in budgetary matters and in making the archives available to the membership and researchers.

The Al-Anon World Service Office archives is a reservoir of material for Al-Anon and Alateen members, informing them of the heritage of their founders and giving them a sense of their past.

The Archives Committee is concerned with gathering, organizing, protecting and preserving the factual, documented history, past and present, of the Al-Anon Family Group fellowship, maintaining the ongoing history of the World Service Office in accordance with the goals of the original Clearing House. It will strive to do everything necessary to inspire a love for and create interest in all things pertaining to Al-Anon/Alateen.

Its aim is to make information available and to assist and inform the serious researcher, within the framework of our Traditions, for the good of Al-Anon as a whole. [36]

**10. International Coordination Committee:** In a world besieged with rapid change, the International Coordination Committee strives to perpetuate worldwide unity.

The Committee coordinates the activities of the WSO with those of individuals, groups and service arms outside the U.S. and Canada. It also considers requests for permission to reprint CAL worldwide and its translation into all languages.

When Al-Anon Family Group Headquarters was established, there were only a few wives of A.A. members overseas. As Al-Anon grew in other lands, groups and local service centers were formed. Ultimately, with the guidance and encouragement of the WSO, national service offices evolved.

With the growth of Al-Anon and Alateen in over 70 countries by 1978, carrying a unified message became increasingly complex. The International Coordination Committee was then formed. [37]

Plans for a meeting with Delegate representation from every country began with the inception of the International Coordination Committee. Such a meeting was envisioned as the most effective means to foster the sensitive communication needed to provide a uniform service message amid language and cultural differences. In 1984, after three trial biennial sessions, the International Al-Anon General Services Meeting became a permanent part of our structure. [38]

**11. Cooperating with the Professional Community** had been one of the activities of Public Information until it became apparent that this service required and deserved more intensive attention. A separate committee, Cooperating with the Professional Community, was formulated on a trial basis in 1981 and became permanent in 1983.

The basic responsibility of the CPC Committee is to generate goodwill and facilitate the exchange of information between the World Service Office, the Al-Anon/Alateen groups, and among professional organizations, government agencies, and others with whom we must have contact to carry the Al-Anon message of hope.

▶ The broad objective of the committee is to make Al-Anon better known to professionals nationally and internationally as a resource for families and friends of alcoholics. It is often the professional who is the first to be consulted or to recog-

nize the pain of the relative or friend of the alcoholic. The professional, familiar with Al-Anon, is in a position to guide a troubled person to our program at a time when he may be most receptive. The committee encourages the membership to make contact with professionals at the area and local level.

Using recommendations from the fellowship, guidelines are formulated and material is developed for working with professionals.

In establishing a CPC Committee, we follow Bill W's suggestion of being friendly with our friends, the professionals. We need to develop and improve communication with professionals in medicine, religion, law, and education, and with employers, governments, courts, prisons, mental hospitals, and other enterprises in the field of alcoholism. [39]

Our hope is to improve cooperation between Al-Anon and the professional community by providing information about who we are, what we are and where we are, what we cannot do and what we can do.[40]

- 12. Regional Service Seminars** encourage direct communication between World Service Office staff, members of the Board of Trustees and service-minded Al-Anon/Alateen members from the region.

Since 1961, contact between the areas and the WSO has been available mainly through Delegates to the World Service Conference. In 1979, striving to stimulate service by increasing communication at the grassroots level, the World Service Conference approved holding service seminars in the six regions of the United States and Canada on an experimental basis. They proved effective, and the 1983 WSC voted to have this method of communication, so vital in building a strong fellowship and in ensuring its future, become a part of our structure. [41]

This committee reviews bids from the host region, coordinates the event, selects personnel to attend, and formulates the agenda based on requests from within the region.

The committee depends on Delegates who act as their link to the groups to suggest topics for seminar workshops and presentations. Thus, each member has an opportunity to share joy and concerns surrounding service to the fellowship. [42]

### **The Executive Committee**

The Executive Committee is not considered one of the standing committees since it is the administrator of the WSO, with legal authority bestowed by the Board of Trustees to conduct its day-to-day affairs. Its membership of seven includes the Executive Director, a member from the administrative staff of the World Service Office, [43] the chairperson of both the Policy and Budget Committees, and three responsible Al-Anon members. The chairperson and the three members are elected by the Trustees.

All new projects considered by any of the standing committees should first be submitted to the Executive Committee for its approval and to the Budget Committee if greater expenditure of money than authorized by the budget is contemplated. However, any project that entails a change in policy should be first brought to the Policy Committee for consideration.

### **The Forum [44]**

For many years the editor of *The Forum*, appointed by the Trustees, picked up letters accumulated periodically in her file at the WSO, wrote the article, and did the layout for an ensuing month's edition. Before publication, this was checked by the Executive Director [45] and the chairperson of the Policy Committee.

Then an Editorial Committee was formed that names its own successors, subject to the approval of the corporate Board. In 1991, the World Service Conference approved the motion to have a volunteer Trustee appointed as chairperson of The Forum Editorial Committee and a staff administrator to compile the magazine. [46] The Editorial Committee assists the staff administrator [47] and staff in determining the editorial policy and content of the magazine. This committee makes recommendations respecting *The Forum* promotional material going to the groups. [48] Our Editorial Committee, therefore, is the chief guarantor of the magazine's quality and editorial continuity.

In 1982, The Forum Business Operations Committee was formed to oversee the business and promotional aspects of *The Forum*. To date the office has handled all subscription data. [49]

### **Principles That Operate in WSO**

#### **Qualities Needed for a Good Al-Anon Executive**

No active service can function well unless it is managed by a competent executive. It must always be directed by *one person*, supported

by such assistants as are needed, not by a board or a committee that cannot effectively manage on a day-to-day basis. This function must be delegated to an individual with ample freedom and authority to do his job without interference, so long as his work is done well.

Real executive ability is rare and hard to come by. A special combination of qualities is required. The executive must inspire by energy and example, thereby securing willing cooperation. If that cooperation is lacking, he must know when real firmness is in order. He must act without favor or partiality. He must comprehend and execute large affairs, while not neglecting the smaller. He often must take the initiative in planning.

Executives with natural drive and energy may sometimes fail to distinguish between routine execution of established plans and policies and the *making* of new ones. In this area they may tend to make new plans and put them into operation without sufficiently consulting those whose work is to be affected or those whose experience and wisdom is actually or officially needed.

A good executive is, necessarily, a good salesman. He would not be satisfied with a fast sell and quick results on those occasions where patient consultation with many people is in order. Nor would he timidly delay or constantly request direction. The executive who overdrives can be reasonably restrained by the structural situation and guidelines within which he has to work. But a weak and wobbly executive is of little use at any time.

It is the duty of the good executive, therefore, to know when to ask for specific definitions and directions and when to make his own decisions. This choice is structurally guaranteed by the Right of Decision. If his judgment is wrong, it can always be brought to his attention.

Certain key people at the World Service Office must be Al-Anon members. The clerical staff may or may not be. This could pose a problem, literally one of possible discrimination. As in the management of any business, the prime consideration is getting the job done well. It is important that the executive personnel make no distinction between Al-Anon and non-Al-Anon workers. While a reasonable amount of direction and discipline is necessary, it should be applied with fairness and equality. (*See Appendix for A.A.'s rotation system.*)

### **Paid Workers, How Compensated**

The World Service Office is constantly hampered by lack of sufficient money to hire full-time top executives. But when we can

afford it, each paid executive, staff member, and worker should be compensated in relation to similar services and abilities in the commercial world.

This policy is often misunderstood. Many Al-Anons regard world services as a sort of necessary charity to which they must contribute. It is forgotten that our particular charity benefits not only the newcomer, but is designed for the general welfare and protection of us all. We are not like rich benefactors who aid the sick and the poor. In helping others we help ourselves.

Another mistaken idea is that our paid workers, especially Al-Anon members, should labor cheaply. This would mark our service workers for unusual financial sacrifices, sacrifices that we would ask no other Al-Anons to make. Besides, inexpensive help is apt to feel insecure and be inefficient and is costly in the long run. This is neither good spiritual practice nor good business.

The difference between fair and poor pay at world headquarters is a matter of only a few cents a year to each member. Al-Anon's world service overhead is very small per capita for such a large society. Assuming that service money is available, we should compensate our workers well.

### **The Importance of Full Participation of Paid Workers**

We have already discussed the importance of giving key paid personnel a voting representation on our committees and corporate boards.

In human affairs, authority and money are closely linked. Control of money can spell control of people. Unwisely used, as it often is, this control can result in an unhappy situation.

In our Al-Anon structure of service we, therefore, must do more than give our paid workers a place at the council table. We ought to treat them in all respects as we do our volunteers. The fact that they are dependent upon the money they receive should never, consciously or unconsciously, be used as a lever against them. They must be made to feel that they are on the team. If, however, they cannot or will not do their jobs, that is something else. We can and should let them go. No organizational structure can fully guarantee our WSO against the possible damage done by clashing personalities. Only sustained willingness to practice spiritual principles in all our affairs can accomplish this.

## Concept Twelve

### ***The spiritual foundation for Al-Anon's world services is contained in the General Warranties of the Conference, Article 12 of the Charter.***

In order that the Conference shall never become the seat of perilous wealth or power, the General Warranties of the Conference read: "In all its proceedings the World Service Conference of Al-Anon shall observe the spirit of the Traditions":

1. that only sufficient operating funds, including an ample reserve, be its prudent financial principle
2. that no Conference member shall be placed in unqualified authority over other members
3. that all decisions be reached by discussion, vote and, whenever possible, by unanimity
4. that no Conference action ever be personally punitive or an incitement to public controversy
5. that though the Conference serves Al-Anon, it shall never perform any act of government, and that, like the fellowship of Al-Anon Family Groups which it serves, it shall always remain democratic in thought and action

Our Conference Charter is an informal agreement made between the Al-Anon groups and their Trustees in 1967 and is the basis upon which the World Service Conference operates. In general, the Charter is a flexible document, since its first eleven articles can be readily amended by the Conference at any time.

But Article 12 stands by itself. An amendment or a cancellation of any of its vital Warranties would require the written consent of three-quarters of all the registered [50] Al-Anon groups. Each group should vote on any such proposals after taking at least six months for careful deliberation. Thus, changes in the Warranties have been made difficult but not impossible.

It is believed that all of these Warranties are permanently important to Al-Anon's general welfare. A change in them should be made only upon positive evidence of some defect, and then only by common consent of the Al-Anon groups. They rank, therefore, with the Twelve Traditions and are as important to Al-Anon's world services as the Traditions are to the groups.

All the Warranties counsel prudence—prudence in personal relations, prudence in money matters, and prudence in our contacts



with the world about us. For Al-Anon, prudence is a middle ground, a channel between fear on the one hand and recklessness on the other. Prudence creates a climate of harmony, effectiveness, and consistent spiritual progress. These Warranties express the wisdom of taking thought for the future based on lessons of the past. They protect us against needless errors and the natural human temptations of wealth, prestige, and power.

The Conference above all should feel bound by the Al-Anon Traditions. Indeed the Conference is named “the guardian of the Traditions.” The Traditions, which express the principles and attitudes of prudence, set the pattern of unity and of function which our World Service Conference is expected to exemplify.

“In order that the Conference shall never become the seat of perilous wealth or power” does not mean that the Conference should have virtually no money and no authority. We must use some money, and there must be some authority. But how much? How and where should we draw the line?

The principal protection against too much money and too much power is to be found in the Traditions themselves. So long as our Board of Trustees refuses to accept outside contributions and sets a modest limit on each member’s gift to Al-Anon’s world services, we shall not become wealthy to a perilous degree. Indeed, it seems that the chief difficulty will continue to be that of effectively informing the Al-Anon groups as to the actual financial needs of the World Service Office and their responsibility to support it. It is certain therefore that we shall never become too wealthy through group contributions. We need only to avoid the temptation of accepting money from the outside world.

There can be little risk either in giving Delegates, Trustees, and Staff the necessary authority. Experience indicates that we are unlikely to encounter problems of too much service authority. On the contrary, our difficulty may be to maintain enough of it. We are protected from too much authority by participation, by the Right of Appeal, and by our Charter. A leader who demands too much authority could not long remain in leadership. Our Delegates, directly representing the groups, control the ultimate supply of our service funds. This constitutes a direct check upon the rise and use of personal power. Taken altogether, these factors should be reliable safeguards against too much money and too much authority.

But there is another sort of authority and power that the Conference cannot be without, the spiritual power that flows from the activities and attitudes of truly humble, unselfish, and dedicated Al-Anon servants. They do not rule by mandate, they lead by example. This is the real power that makes our Conference function.

## Warranty One

***Sufficient operating funds, including an ample reserve, should be its prudent financial principle.\****

Our attitude toward the giving of time, compared with giving money, presents an interesting contrast. We give much time to Al-Anon activities for the sake of our groups, our areas, and Al-Anon as a whole, as well as for our own protection and growth. We often take time from home duties or business to do Twelfth Step work. We do not think these sacrifices are unusual. We remember that people once gave their time to us as we struggled for understanding.

But when it comes to the spending of cash for Al-Anon service overhead, many of us turn reluctant. When we drop money in the meeting basket, its usefulness is not as obvious as when we talk to a newcomer. There is no romance in paying the landlord. Sometimes we hold back when asked to meet area or Intergroup service expenses. As to world services, we may remark, "Well, our group doesn't get anything out of it. Let's not spoil Al-Anon with money and service organization. Let's keep things simple."

These reactions are natural and understandable, easy to justify. But they quickly disappear when the real need for a given Al-Anon service is made clear by right information and education. We see this in the ever-better job now being done by Delegates, District Representatives, and Group Representatives, who are finding that raising money by pressure and exhortation is not needed in Al-Anon. When each member can be shown how much the service dollar really buys in terms of helping families to find Al-Anon, contributions are willing and generous.

We can take comfort, too, from the fact that the cost of our world services is small in relation to the size of our fellowship. Our paid workers at the WSO are comparatively few.

---

*\* Note: The Warranties are found in the Conference Charter. The wording above, drafted by our co-founder Lois W. and approved by the 1970 World Service Conference, is part of the descriptive text and not the actual Warranty.*

Not until 1966 was the Board of Trustees able to establish a Reserve Fund. Until then the Trustees each year hoped and prayed that the budget would be met by contributions and literature sales. Fortunately this turned out as they hoped. But such a hand-to-mouth system of finance, although inevitable in our early years, is not a prudent one for the future.

At present, group contributions pay for only a portion of the World Service Office expenses; the balance is financed by the sale of books and booklets. It is firmly believed that, as the groups understand the situation more clearly, their contributions will continue to increase, so that the World Service Office may soon be able to build up a sufficient reserve to carry it through an emergency, such as a financial depression.

Arguments pro and con the establishment of a Reserve Fund are these:

### **Is a Reserve Fund needed?**

As this is written, in 1969, our headquarters operation is breaking even. Compared with earlier days, this is wonderful. Nevertheless this condition is in a period of great prosperity. What would it be like in bad times without a reserve? Suppose the WSO income were greatly decreased by a depression, or expenses increased by a steep inflation. We might be faced by a gaping deficit that would make it necessary to discharge part of our paid workers and staff members. Mail would go unanswered, requests for information would not be properly serviced. *The Forum* might have to be reduced to its former size. The number of Delegates attending the annual World Service Conference might have to be drastically reduced. These could be the penalties if we did not have a Reserve Fund to fall back on. Is it not wise for us to increase our savings whenever possible, especially in good times?

### **If the Reserve Fund continues to grow, will "perilous wealth" result?**

There are so many present needs for more working capital that it is hard to imagine having too much. Al-Anon's foreign-aid field is just beginning to open up in a large way. Translators and translations are needed. Our continuous growth constantly increases salary expense as more staff is needed. Members of the WSO occasionally are asked to visit distant groups as speakers at anniversaries, conventions, etc. If there were more funds available, headquarters could encourage this by offering to pay part of this most informative and useful travel. There is nothing like personal contact for arousing interest and enlarging understanding.

The Reserve Fund would never be permitted by the Conference to become excessive.

**Will the presence of such a fund discourage group contributions?**

We believe that further education will help the groups understand the need of such a fund and that it will have little or no effect on their contributions. The Delegates have already done much toward informing the groups about this.

**Does the establishment of a Reserve Fund mean that we lack faith in God's providence?**

Are we not expected to exercise a reasonable amount of foresight in the conduct of our affairs? This is certainly no denial of faith in God's providence; it is instead a willingness to shoulder our own clear responsibility and so merit His trust in us.

**Should our books and other literature be sold at cost so that hard-pressed members could purchase them more easily; or sold for less to encourage the general public to buy them?**

No, because this would mean sacrificing the support of Al-Anon's world services for small financial advantages to individual members. Experience shows that without a modest profit on literature, the WSO could not pay for its many worldwide services. Money charity to members is not the function of the group, Intergroup, or World Service Office.

If a member cannot afford to buy a book, his sponsor may give or lend him one. Many libraries carry our books. Groups sometimes sell books on the installment plan to aid newcomers. If the group undertook to assist individual members financially, the group kitty, which is for the benefit of all members, would soon be dissipated. The same would be true if WSO sold books or literature at cost.

Because of its specialized character there is no reason to believe that large sales of

Al-Anon literature could be made to the general public even at lowered prices. To publish in paperback would not be an answer, either: Publishers tell us that paperback issues nearly always destroy the circulation of hardcover books.

**Does so-called "profit-making" on our books and pamphlets go counter to sound spiritual principles?**

Many groups, as well as the WSO, sell books for a little more than cost. Actually, this is not a profit after all, but further contributions which the member-buyers make to the general welfare of their

groups or WSO. The certain and continuous solvency of our world services rests squarely upon these contributions. Looked at in this way, the Reserve Fund is seen to be the aggregate of many small financial sacrifices made by individual members for the good of the whole fellowship.

## Warranty Two

***None of the Conference members shall ever be placed in a position of unqualified authority over any of the others.\****

The application of this principle has already been extensively discussed under Concept Four, Participation is the key to harmony. It is so important, however, that it is the subject of this Warranty, thus ensuring that Conference action alone can never overturn or amend the Right of Participation. For such a purpose widespread group consent would be needed, which might be difficult though not impossible for the Conference to obtain. Our whole service experience fully justifies taking this strong stand against the creation of unqualified authority at any point in our Conference structure.

This Warranty against absolute authority is far more general and sweeping in its nature than a guarantee of voting participation. It really means that we in Al-Anon do not want or need absolute human authority in any form.

Article 12 of the Conference Charter might be called “The Service Bill of Rights,” because these Warranties, and especially this one, express deep and loving respect for the spiritual liberties of our fellows. May God grant that we shall never be so unwise as to desire anything less.

## Warranty Three

***That all important decisions be reached by discussion, vote and, whenever possible, by substantial unanimity.\****

Here, on the one hand, we erect a safeguard against any hasty or overbearing authority of a simple majority; and on the other hand, take notice of the rights and the frequent wisdom of minorities, however small. This principle further guarantees that all matters of importance will be extensively debated, until a really heavy majority can support every critical decision we are called upon to make in the Conference.

---

\* See footnote “Warranty One”

The Conference voice would thus speak with authority and confidence beyond that which a simple majority could confer. If any persons remain in opposition, they are likely to be better satisfied because their views have had a full and fair hearing.

The principle of substantial unanimity does, however, have certain practical limitations. Occasionally a matter will be of such extreme urgency that a Conference decision must be made at once. In such a case a minority, however well-intended, could not be allowed to block a vitally needed action or one which is evidently in the best interests of Al-Anon. Here we shall need to trust the majority, sometimes a mere majority, to decide whether Conference debate is to be terminated and a final decision taken. In certain other cases, the majority will also have to exercise its prerogative. Suppose, for example, that a small minority obstinately tries to use the principle of substantial unanimity to block a clearly needed action. In such an event it would be the plain duty of the majority to override such a misuse of the principle of substantial unanimity and call for a vote.

However, majorities will probably seldom need to take such radical stands. If and when they do, the Conference will have to decide, by a simple majority vote, what the requirements of substantial unanimity should be, whether two-thirds, three-quarters, or an even greater majority.

The practical and spiritual results of substantial unanimity will make itself evident.

## Warranty Four

***That no Conference action ever be personally punitive or an incitement to public controversy.***

Practically all societies and governments feel it necessary to inflict personal punishments upon individual members for violations of their beliefs, principles or laws. Because of their spiritual character both Alcoholics Anonymous and Al-Anon find this practice unnecessary. When A.A.s fail to follow sound spiritual principles, alcohol cuts them down. It is not so obvious with us of Al-Anon. It is easier for us to fool ourselves that we are right and that our indignation is justified. However, anger and resentment betray us, and we soon recognize we've had a "slip." Therefore no humanly administered system of penalties is needed in either society. This unique condition is one on which we can fully rely and one which we should

never abandon by resorting to personal attack or punishment. For much the same reason we cannot and should not enter into public controversy, even in self-defense. Nothing could be more damaging to our unity and to the growing goodwill Al-Anon enjoys than public contention, no matter how promising the immediate dividends might appear.

Therefore, it is evident that the harmony, security, and future effectiveness of Al-Anon will depend largely upon our maintenance of a thoroughly nonaggressive and pacific attitude in all our public relations.

If we recognize that religion is the province of the clergy, the practice of medicine is for doctors, and social welfare, for social workers, we can helpfully cooperate with all. Certainly there is little basis for controversy in these areas. Al-Anon has no concern with reform or politics. We should strictly mind our threefold purpose.

Because our World Service Conference represents us all, it is especially charged with the duty of setting the highest possible standards with respect to these attitudes.

The Conference, however, may sometimes have to apply these principles to specific situations and take certain protective action, especially in the area of Tradition violation. This action, however, need never be punitive or aggressively controversial. When the infractions have serious implications, the WSO consults the Conference for its advice and direction. For the more routine deviations the WSO takes appropriate action, which it reports to the Conference at its next session.

Let us take some situations that would require consideration and decision:

- Suppose that Al-Anon falls under sharp public attack or heavy ridicule with little or no justification in fact.

Almost without exception, it can be confidently estimated that our best defense would be no defense whatever—namely, complete silence at the public level. Unreasonable people are stimulated all the more by opposition. If in good humor we leave them strictly alone, they are apt to subside the more quickly. If their attacks persist and it is plain that they are misinformed, it may be wise to communicate with them in a temperate and informative way; also in such a manner that they cannot use our communication as a springboard for fresh assault. Such communication need not be made by

the World Service Office officially. Very often we can use the good offices of friends. Such messages should never question the motives of the attackers, but should be purely informative. These communications should also be private. If made public, they will often be seized upon as a fresh excuse for controversy.

- If, however, criticism of Al-Anon is to any extent justified, it could be acknowledged privately, together with our thanks. Then we might be confronted by public violations of the Al-Anon Traditions. Individuals, outside organizations and even our own members sometimes may try to use the Al-Anon name for their own private purposes. As Al-Anon grows in size and public recognition, the temptation to misuse our name may increase.

It has been said, “Al-Anon is prepared to give away its knowledge and experience—all except the Al-Anon name itself.” Our principles can be applied in any situation. We do not wish to monopolize them. We simply request that the public use of the Al-Anon name be avoided by those other agencies who wish to avail themselves of Al-Anon techniques and ideas. In case the Al-Anon name should be misapplied, it would of course be the duty of our World Service Conference to press for the discontinuance of such a practice—avoiding, however, public quarreling about the matter.

The Conference, as we know, is the guardian of the Traditions. But this does not imply the right nor the duty of the Conference to publicly punish or sue every willful violator. Such aggressive public acts would place the Conference in the position of having violated one of its Traditions in order to defend another.

Privately, however, violators of our Traditions can be informed that they are out of order. If they persist, our resources of persuasion may be used. Consistent firmness will often bring the desired result.

In the long run, though, we shall have to rely mainly upon the pressures of Al-Anon and public opinion. We shall need to maintain continuous education of the public through communication channels of all kinds.



Experience has shown that continuous and general education respecting our Traditions will be a reliable protection in the years to come.

[See Appendix—Protection of A.A.'s Name.]

- Severe internal disagreement among us that comes to unwelcome public attention is unlikely to occur in Al-Anon, but it did in A.A.. [*See Appendix—A.A.'s experience with internal disagreement.*]

What should our World Service Conference do about this should it ever happen?

Always remembering group autonomy and the fact that Al-Anon's world headquarters is not a government, the best course is usually to make an offer of mediation. What the Tradition means, and what our experience has been, can be recounted. Avoidance of any breakthrough to the public level should always be urged and all parties be reminded that an unfavorable public image could keep new prospects from joining Al-Anon.

Many of these difficulties with the Traditions represent honest differences of opinion in interpretation of the Traditions. The Traditions sometimes reveal gray areas where violations are often debatable and inconsequential. In such cases we refrain from offering suggestions, unless they are insisted upon. Many such problems can be solved by the local people concerned.

- It is possible that some day might see a deep rift dividing either or both A.A. and Al-Anon—a cleavage of opinion so serious that it might involve a withdrawal of an appreciable proportion of members into a new society or one faction's making an alliance with an outside agency, ignoring the Tradition. It might be powered by religious, political, national, or racial\* forces. It might represent an honest effort to change for the better, but it would certainly pose a serious question of what to do.

Such a contingency is hard to imagine, yet this is no reason for refusing to give it calm forethought. If it ever came, its development might be such a terrific surprise and shock that aroused passions could flare, making any constructive solution difficult, perhaps impossible.

---

\* This corrects a typesetting error printed in earlier versions.

Particularly today, when society everywhere is in such a state of fission, this possibility must be considered. The best attitude in such a circumstance might be complete nonresistance—certainly no anger, no attack. Al-Anon has no doctrine that has to be maintained. There is no authority that has to be supported; no prestige, power, or pride that has to be satisfied. And we have no property or money that is worth quarreling about. In the event of a threatened major division, the best possible use should be made of these advantages in a calm and considered attitude of nonresistance.

We have always practiced this attitude on a lesser scale. If a member says there is too much dominance by one person in her group, we simply say, “Why don’t you try another one? Or start one of your own.” If individual members wish to gather together for retreats, Communion breakfasts, or any undertaking whatever, we still say, “Fine. Only we hope you won’t designate such activities as an Al-Anon group or enterprise.”

In the event of an extensive split we would not waste time persuading the dissenters to stay with us. Should they become happier and more serene under new auspices and changed conditions, we would ask ourselves if we could not learn from their fresh experience.

## Warranty Five

***That though the Conference serves Al-Anon, it will never perform any act of government; and that, like the fellowship of Al-Anon Family Groups which it serves, it shall always remain democratic in thought and action.\****

In preceding Concepts, attention has been drawn to the extraordinary liberties that the Traditions accord to the individual member and group. No penalties are to be inflicted for nonconformity to Al-Anon principles, no fees or dues levied; contributions are always voluntary. No member can be expelled from the fellowship; membership always is the choice of the individual. Each group conducts its internal affairs as it wishes, only abstaining from acts that might injure Al-Anon or A.A. as a whole. And finally, any group of the relatives of alcoholics gathered together for mutual aid may call itself an Al-Anon Family Group provided that as a group it has no other purpose or affiliation.

---

\* See footnote “Warranty One”

Because we set high value on our liberties and cannot conceive of a time when they will need to be limited, we enjoin our World Service Conference to abstain from any act of authoritative government that could curtail Al-Anon's freedoms. To maintain these freedoms the Conference must remain democratic in spirit and in action.

Therefore we expect that our Conference will always try to act with mutual respect and love, one member for another; that no action will be taken in anger, haste or recklessness; that care will be observed to respect and protect all minorities; that no action will be personally punitive; that whenever possible, important actions will be taken in substantial unanimity; and that our Conference will ever be prudently on guard against tyrannies, great or small, whether these be found in the majority or in the minority.

The sum of these several attitudes and practices is the very essence of democracy. Our freedom to serve is truly the freedom by which we live and have our being.

[The wording of the Warranties in this section is an adaptation of A.A.'s Warranties. It is retained here for historical purposes and because it has been in common usage since the adoption of this manual by the 1970 WSC.]

## Amendments made prior to 2005

Original text read:

1. For an appropriate period, any far-reaching structural change should be labeled "experimental." On the final approval, the change can then be entered in this *Manual* in a special section entitled Amendments. This leaves the original draft of the Twelve Concepts intact as a record of former experience.
2. The Conference has practically complete authority over the Trustees despite the legal rights of this Board.
3. To the Executive Committee, *The Forum*, and committees directed by non-Trustee volunteers and paid service workers. The Board of Trustees certainly does not control these entities; their authority is final.
4. The Executive Committee is composed of the Treasurer and the General Secretary both of whom are Trustees.

5. The Conference Secretary [The Composition of the Al-Anon Executive Committee was changed by replacing the Conference Secretary with a member of the Administrative Staff by a charter revision approved by the 1976 World Service Conference.]
6. For communication linkage, the Editor of *The Forum* or a member of the Editorial Committee may be invited to attend Executive Committee meetings without vote.
7. Staff Secretaries
8. However, other than the General Secretary and *The Forum* Editor, no paid staff worker should become a Trustee. First, it would interfere with the rotation of the Board, which already has four nonrotating members, the other two being honorary life members.
9. Any person whose personal life either has been or is being deeply affected by close contact with an alcoholic is free to become a member.
10. The Trustees are Al-Anon's bankers. They are entirely responsible for the use of funds received and for the investment of our reserve.
11. On the one hand we see a Board of Trustees invested with complete legal power over Al-Anon's funds and services; on the other hand Al-Anon's World Service Conference is clothed with such great traditional influence and financial power that, if necessary, it could override the legal rights of the Board of Trustees. It could therefore, give the Trustees directives and secure their compliance.
12. When we reflect that our Trustees have no salaried financial interest in their posts, such a Board would never think of legally contesting the clear and sustained will of the Conference Delegates and the Al-Anon areas they represent.
13. The Trustees certainly do have this legal authority, but in the Bylaws they are quite at liberty to accept advice or even direction from anyone.
14. General Secretary
15. The Conference Secretary
16. If the Delegates must, they can censure or reorganize the Board of Trustees.
17. Public Relations
18. General Secretary

19. With the approval of the Board of Trustees, its Chairman annually appoints committee Chairmen and is himself a member ex-officio of each Committee.
20. The Standing Committees of the World Service Office include: 1. Policy, 2. Alateen, 3. Budget, 4. Conference, 5. Institutions, 6. Literature, 7. Nominations, and 8. Public Relations.
21. The Policy Committee is composed of the Chairmen of all committees and the Al-Anon Staff, and meets quarterly in advance of the Trustees meeting.

The Policy Committee is composed of the Trustees, the Chairmen of all committees and the Al-Anon Staff, and meets quarterly in advance of the Trustees meeting.

22. It is composed of a volunteer Chairman, Staff Secretary and six WSC Delegates. [Material deleted.]
23. It is co-sponsored.
24. In good times the Budget Committee sets aside substantial sums in our Reserve Fund to guarantee the immediate availability of at least two-thirds of it any time, without loss.
25. The Committee is composed of a volunteer Chairman and when possible, an assistant Chairman, the Policy Chairman, the Executive Secretary, the Conference Committee Secretary, all other Staff Secretaries, and any volunteers needed for special assignments. [Material deleted from Conference Committee.]

The Conference Committee is composed of a volunteer Chairman and when possible an assistant Chairman; the Conference Administrator; the Admissions/Handbook Chairman; the Deputy Executive Director; the Staff Administrators who will be making presentations for that year; and three at-large members, preferably with Delegate experience.

26. Institutions Committee: There are several ways this committee helps the families of alcoholic inmates: by correspondence, by directing families to nearby Al-Anon groups, or by aiding in the formation of groups at the hospitals or prisons.

There are several ways this committee helps the families of alcoholics, whether inmates or relatives of inmates; by correspondence, by directing families to nearby

Al-Anon groups, or by aiding in the formation of groups at hospitals, prisons, courts, juvenile facilities, etc.

Soon after Al-Anon Headquarters was formed, A.A. encouraged Al-Anon to contact the families of A.A. patients and inmates who so requested. This resulted in a beneficial correspondence with many of these A.A. families, carried on by one of our early volunteers. Later, the work lagged for several years for lack of an available interested volunteer Chairman, until 1967, when an Institutions Committee was formed with a permanent Staff secretary.

Great care is taken to preserve anonymity in aiding the family to contact a nearby Al-Anon group. This is necessary because the A.A. bears the so-called double stigma of being both an alcoholic and an inmate. The family is relieved upon finding that alcoholism is a disease, since it is often a contributory cause of the inmate's being confined to prison or a mental institution.

27. A key figure in its operation is a paid writer or consultant. [Material deleted.]

The role of the other Committee members is one of constructive criticism of the consultant's effort. [Material deleted.]

28. Broadly speaking, its mission is to see that an adequate and comprehensive view of Al-Anon in its every aspect is presented in writing to our members, friends, and to the world-at-large.
29. The initial form and draft and the final development of new undertakings—the creative work—is the responsibility of this specialist. The role of other Committee members is one of constructive criticism.
30. If the new material is to affect the public, especially in the fields of medicine and religion, a consultation should be held with those trustees or other qualified friends who are knowledgeable in these areas.
31. The recommendations of the Nominating Committee will determine, to a large extent, the continuous success of our services. Its members will have the primary voice in choosing our future Trustees and non-Trustee volunteer workers. Careful deliberation, painstaking investigation and interviewing, refusal to accept casual recommendations, advance preparation of lists of suitable candidates—these need to be

the principal attitudes and activities of this committee. Hasty or snap judgment should be constantly avoided.

32. The Public Relations Committee
33. We need to develop and improve communication with professionals in medicine, religion and education, and with employers, governments, courts, prisons, mental hospitals, and other enterprises in the field of alcoholism. [Removed and transposed into the material describing the Committee for *Cooperating with the Professional Community*.]
34. Public Relations Committee
35. Public Relations
36. [Added material]
37. This Committee is composed of a volunteer Chairman, the Staff Secretary, Staff and volunteer members familiar with Al-Anon on a worldwide level. [Material deleted.]
38. [Added material]
39. [Transposed; see 30, above.]
40. [Added material]
41. The Regional Service Seminar Committee is composed of a volunteer Chairman, the Executive Director, a Staff Coordinator, and two regional Trustees, one who has just hosted a Seminar, the other who is preparing for the next one. [Material deleted.]
42. [Added material]
43. The Conference Secretary
44. The Editorial Committee [previous title of this section]
45. General Secretary
46. Then an Editorial Committee was formed which names its own successors, subject to the approval of the corporate Board. The Editorial Committee assists the Editor and Staff in determining the editorial policy and content of the magazine. It relieves the Editor of some of the work load. It surveys and makes recommendations respecting *Forum* promotional material going to the groups. It is a training ground for future editors. Our Editorial Committee, therefore, is the chief guarantor of the magazine's quality and editorial continuity.  
To date the office has handled all subscriptions.
47. Editor
48. [Added material]
49. [Added material]
50. Directory Listed

# Appendix

*The following A.A. experiences, while not incorporated in our Concepts, are recorded here for reference.*

## **A.A.'s General Policy Committee**

### **Summarized from A.A.'s Concept Eleven**

A.A. has instituted what it calls the General Policy Committee and its description is inserted here in case Al-Anon later decides to use its more comprehensive attributes:

“Several years ago it became evident that the mass of business coming before the quarterly Trustee meetings had become too big to handle. We therefore had to devise a committee to filter all these matters—disposing of the lesser and fully examining the larger. The object was to break the jam at trustee meetings and to present the Board with carefully discussed recommendations, including minority reports, on the more serious issues. Thus the attention of the General Service Board could be accurately focused on what it really had to do. This committee, with ample time at its disposal, could also strengthen our process of planning and policy formation. It could avert blunders, both large and small, due to haste.

“This has worked wonderfully well. Because this committee is designed to be supersensitive to A.A. opinion and reaction, its hard core is composed of (a) the ‘out-of-town’ A.A. Trustees, one of whom is traditionally named Chairman, (b) two staff members of the World Service Office, (c) the president of A.A. World Services, Inc., who is also General Manager of the World Office, (d) the President of the A.A. Grapevine, Inc., who is the Editor, and (e) those Trustees and service Directors known to be long experienced with our Fellowship.

“All other Trustees, committee members and directors and staffs are invited to attend meetings—the Trustees because they can thus get a preview of the questions that will confront them at their own meeting to follow—the committeemen and directors because in this way they will get a comprehensive picture of what other headquarters units have been doing.

“This is a large committee and it operates town-meeting style, requiring four to six hours the Sunday afternoon preceding each Monday quarterly meeting of the General Service Board. A carefully worked out agenda is always prepared. The committee issues



to the trustees a full report of its recommendations, together with any minority views. Its report also shows the actual disposition of minor matters.

“This General Policy Committee has greatly strengthened our headquarters unity. All participants get the feeling that they are ‘on the team.’ The size of the meeting is no obstacle. Many minds, plenty of time, and real sensitivity to A.A. ensure a remarkable effectiveness of policy and planning.

“The General Policy Committee also examines the quarterly reports of the committees, making comments and recommendations respecting them.”

## **A.A.’s Rotation System**

### ***Summarized from A.A.’s Concept Eleven***

Al-Anon’s WSO has never used the rotating system for its administrators, but A.A. has found that rotation of their A.A. secretaries has been successful for several reasons:

- a. Continuity has been preserved. There is no break when a secretary must resign; another has had the necessary experience to fill the gap.
- b. Equality of all staff secretaries.
- c. Added time of service of secretaries, since rotation gives them change in routine and keeps their interest alive.

## **A.A.’s Experience with Internal Disagreement**

### ***Summarized from A.A.’s Concept Twelve***

In one instance A.A. hit the headlines with a pretty hardbitten lawsuit wherein two factions were competing for the possession of the A.A. name for intergroup use, the name having been incorporated by one of them. In another, an overseas area received bad publicity when many of the groups became convinced they ought to accept money subsidies from the country’s government to promote A.A. work, the A.A. Tradition notwithstanding. These internal difficulties should not have surfaced before the public. There was nothing about them that mutual understanding and good temper could not readily have handled.

## Protection of A.A.'s Name

### *Summarized from A.A.'s Concept Twelve*

The protection of its name is of such importance that A.A. once considered incorporating it throughout the world, thereby having legal means to stop any misuse. A.A. even thought of asking Congress to grant the unusual favor of a Congressional incorporation, feeling that such legal remedies might prove to be a great deterrent to misuse.

But after several years of deliberation, the A.A. General Service Conference decided against such a course, becoming convinced that the power to sue would be a dangerous thing for A.A. to possess. A public lawsuit is a public controversy and contrary to the Traditions. To make the legal position secure, it would have been necessary to incorporate the whole Fellowship, and no one wished to see a spiritual way of life incorporated. They decided to trust A.A. opinion, public opinion, and God Himself to take care of Alcoholics Anonymous in this respect.

## **Notes and Updates**

## **Notes and Updates**

## **Notes and Updates**

## Notes and Updates

# Index

## A

- A.A. (See Alcoholics Anonymous)
- AIS (See Al-Anon Information Service)
- Al-Anon Declaration ..... 4, 22
- Al-Anon & Alateen Groups at Work** ..... 7-74
  - Revisions to ..... 103
- Al-Anon Information Service (AIS)/Intergroup..... 63-65, 71, 100-101, 112-114, 119, 120, 162, 166
- Al-Anon Member Involved In Alateen Service (AMIAS) ..... 31-34, 49, 71, 87-90
- Al-Anon's Twelve Concepts of Service** (See Concepts of Service) ..... 179-225
- Al-Anon World Service Conference Charter ..... 171-175, 192, 193, 195, 204-205, 214, 225
  - History and purpose of ..... 214-216
- Alateen
  - Alateen Advisory Committee ..... 69, 208, 212
  - Alateen groups/meetings ..... 31-34, 87-90
    - age range ..... 89-90
    - in schools and other facilities ..... 90
    - naming the group ..... 35-36, 81-82
    - registration ..... 31-33, 87-88
    - special open meetings ..... 33-34, 89
    - starting an Alateen group ..... 31-33, 87-88
    - who attends an Alateen meeting ..... 33-34, 89
  - Alateen Policy ..... 87-90
  - Alateen service
    - Al-Anon group support ..... 31-33, 90
    - Al-Anon Member Involved in Alateen Service (AMIAS) ... 31-34, 49, 71, 87-90
    - Alateen Group Sponsor ..... 31-34, 49, 71, 82-83, 87-90
    - Alateen Personal Sponsor ..... 49, 71, 89
    - Area Alateen Coordinator ..... 72, 87-88, 162, 164
    - Area Alateen Process Person (AAPP) ..... 72, 88
  - Area Alateen Process ..... 32-33, 87-88
  - Area Safety and Behavioral Requirements ..... 31-32, 87-88
  - events with Alateen Participation ..... 90
  - finances/Seventh Tradition ..... 33, 90
  - history of Alateen ..... 29
  - locating a meeting ..... 34, 83
  - Preamble, Alateen ..... 12
  - Traditions, Alateen ..... 17-18
- Alcoholics Anonymous (A.A.)
  - clubhouses ..... 57, 121-122
  - conferences/conventions ..... 120
    - events with Alateen participation ..... 90
  - cooperation with ..... 120
  - dual membership ..... 31, 40-41, 47-48, 81, 82-83, 146, 148, 150
  - General Policy Committee (A.A.'s) ..... 287-288
  - literature ..... 104
- Alcoholism
  - Understanding Ourselves and Alcoholism* (P-48) ..... 25-27

Alternate positions (See Elections/duties)	
Amendments to the Concepts of Service.....	229-286
Anne B. (Al-Anon Co-founder) .....	28
Announcements at group meetings .....	55-56, 123-124
Anonymity	
definition .....	23, 41-43, 50-51, 91-94
in Al-Anon/Alateen service .....	91-94
in the media .....	41-43, 50-51, 91, 114-116
in our personal growth .....	94
on the Internet.....	41-43, 91, 93, 114-116
outside Al-Anon/Alateen .....	41-43, 91-94, 110-116
Tradition Eleven.....	42, 91, 114
videotaping/filming .....	84, 86, 91, 114
with professionals .....	50-51, 91-92, 110-111
within Al-Anon/Alateen.....	40-43, 92-94
Answering Services.....	100
Appeal letter, Quarterly .....	47, 58, 95-96
Appendix.....	287-289
Area (See also Assembly).....	65-66, 72-73, 142-145
dividing of populous Areas .....	142-143, 173
Area Alateen Process Person (AAPP).....	72, 88
Area Coordinators .....	65, 72, 82-83, 87, 131-132, 152, 156-157
Area Officers .....	65-66, 150-152
Chairman.....	65 72, 150-155
Delegate (see also World Service Delegate).....	65-67, 72, 134, 141-145, 149-152, 173
Secretary.....	159
Treasurer .....	159-160
Area World Service Committee (AWSC) .....	66, 72, 132, 149, 162-163, 166, 174
Assembly, Area .....	65, 72, 132, 153-164, 166
duties of Assembly members.....	155-162
election Assembly .....	141-142, 149-153
finances .....	147, 152-153
interim Assemblies .....	163-164
post-election activities .....	152
Attraction vs. promotion (See Public Outreach)	
Autonomy .....	101, 225
AWSC (See Area World Service Committee)	

## **B**

Baby-sitters.....	99
Bank accounts, group.....	58-59
Basics for group meetings .....	40-48
Basic terms used in Al-Anon/Alateen Service.....	70-74
Beginners' meetings.....	37, 41, 45
Bequests .....	96
Birthday plan.....	95
Board of Trustees (See World Service Office)	
Business meeting, group.....	51-53
By-Laws .....	137, 172, 174



## C

CAL (See Conference Approved Literature)	
Caucus .....	132, 150
Charter (see Al-Anon World Service Conference Charter)	
Clearing House .....	28, 139-140, 181-183, 196-198
Closing, Suggested .....	22
CMA (Current Mailing Address).....	32, 34, 38, 39, 47, 51, 52, 70, 156, 158
Combined giving campaigns .....	95
Committees, WSO Selected (See Concept Eleven)	
<b>Concepts of Service</b> .....	179-225
revisions to .....	180-181
Concept One .....	181-183
relation to Tradition Two.....	181-183
Concept Two .....	183-185
authority/responsibility, delegated.....	183-185
Concept Three .....	185-188
leadership discretion .....	185-188
right of decision .....	185-188
Concept Four .....	188-190
principle of participation.....	188-190
Concept Five.....	190-193
group conscience as final authority.....	191
protection of minority opinion .....	190-193
veto power of Board of Trustees.....	192
Concept Six .....	193-194
administrative responsibility of Board of Trustees .....	193-194
Concept Seven.....	194-196
legal authority/veto power of Board of Trustees.....	194-196
traditional authority of the Conference.....	194-196
Concept Eight .....	196-198
history of the World Service Conference.....	196-198
responsibility of the Executive Committee.....	197
Concept Nine.....	198-202
Leadership essay by Bill W.....	199-202
Concept Ten.....	203-207
authority/responsibility.....	203-207
double-headed management .....	206-207
Board of Trustees.....	205-206
World Service Conference .....	203-205
Concept Eleven.....	207-214
committees (selected committees).....	68-69, 133, 136-139, 166-161, 207-213
qualities of executives and staff .....	213-214
Concept Twelve .....	214-225
Al-Anon World Service Conference Charter.....	171-175, 214-225
Conference role in the WSO structure.....	215-216
Warranties .....	20, 214, 216-225
Conference (See World Service Conference)	
Conference Approved Literature (CAL) (See also Literature).....	60-62, 102-108
authorization for production.....	103
CAL seal.....	102, 103, 106-107
development of.....	102-103
identification of .....	103

posting on-line .....	84, 108
reprint authorizations .....	107-108
sale of.....	57, 64, 72, 100, 108
translations of .....	108
use of material at meetings .....	104
Conference approval process.....	61-62, 73, 102-103
Conference Charter (See Al-Anon World Service Conference Charter)	
Conference Committee on Trustees (CCT) .....	208, 210
<i>Conference Summary</i> .....	60, 66-67, 105, 145
Contacts, group, phone.....	34, 47, 70
Contributions (See Financial Matters)	
Copyrights .....	106
Conventions/Other events.....	85-86, 97, 120, 123-124
events with Alateen participation .....	90
distribution of proceeds .....	85
Coordinators, Area .....	65, 72, 82-83, 87, 131-132, 152, 156-157
Current Mailing Address (CMA).....	32, 34, 38, 39, 47, 51, 52, 70, 156, 158

## D

Declaration, Al-Anon.....	4, 22
Delegate (See World Service Delegate)	
Democratic process .....	20, 174-175, 225
<b>Digest of Al-Anon and Alateen Policies</b> .....	79-125
revisions to .....	79-80
Dilution of the Al-Anon Program.....	124-125
Discounts and services.....	97
Districts .....	63, 71, 132, 148, 164-165
District meetings.....	132, 164-165
District Representative (DR).....	63, 65, 66, 71, 132, 141-142, 148-149, 157-158
Dominance .....	24, 54-55
Dual Membership in Al-Anon/Alateen and A.A. ....	31, 40-41, 47-48, 81, 82-83, 146, 148, 150

## E

E-mail addresses.....	34, 92, 93-94
Elections	
Alternate Delegate.....	134, 151-152, 161-162
Alternate District Representative.....	65, 148
Alternate Group Representative.....	47-48, 146-147, 155-157
Area Delegate (See also World Service Delegate) .....	65, 72, 149-151
Area officers .....	132, 152
District Representative .....	65, 148, 150
Group Representative .....	47-48, 146-147, 155-157
Information Service Representative and Alternate.....	48, 65, 147
Electronic meetings (Internet, phone).....	38-39, 84
Eleventh Tradition (See also Anonymity) .....	42, 50, 91-94, 114-115
Employees in Al-Anon services .....	101, 134, 213-214
Equalized expenses (See also World Service Conference).....	145-146, 152-153
Executive Committee, WSO.....	137, 196-198, 209
Executive Director, WSO .....	133, 136-139, 188-190, 208, 213

## F

Family disease .....	25-27
Films at meetings/events .....	84, 86
Financial Matters.....	95, 99
Al-Anon Information Service/AIS/Intergroup.....	63-65, 96
Area Assembly.....	147, 152-153
avoiding commercialism .....	97
combined giving campaigns .....	95
contributions .....	21, 56-58, 95-96, 97, 99
outside contributions .....	97
to WSO.....	56-58, 95-96
Delegate's expenses.....	145-146, 152-153
discounts and services .....	97
district .....	148-149
group .....	56-58, 95-99, 147, 157
payment for speaking.....	98-99
reserve fund .....	96-97, 214-219
self-support, Seventh Tradition.....	9, 21, 33, 56-59
use of group funds .....	56-59, 99
<i>Forum, The</i> .....	43-44, 47, 55, 61, 94, 104-105, 164, 211
<i>Forum</i> Editorial Advisory Committee, WSO.....	69, 211
Four primary ideas.....	23-24
Fundraising.....	97-98, 164-165

## G

General Service Office (GSO).....	67, 73, 133
General Warranties listed (See also Warranties).....	20
Gossip .....	23-24, 54-55
GR (See Group Representative)	
Group (See also Meetings)	
autonomy (Tradition Four).....	101
business.....	51-59
announcements .....	55-56, 123-124
bank accounts .....	58-59
budget.....	56-58
business meeting.....	51-53
cooperation with A.A.....	120
EIN (tax ID number) .....	58-59
finances.....	56-59, 95-99
group inventory.....	53-55
group conscience.....	51, 53
insurance.....	59
home group.....	40, 82
growth, group .....	49-51
public outreach.....	49-51, 109-116
meetings	
closed meetings .....	36-37, 83, 89
in clubhouses .....	57-58, 121-122
in institutions (Introductory meetings).....	83-84
locating.....	83, 100
meetings with a special format or designation .....	35-36

open meetings.....	36-37, 83, 89, 99
sharing at meetings.....	40-41, 123-125
names .....	35-36, 81-82
problems and solutions.....	54-55, 83
discussion of religion.....	24, 54, 123-124
dominance .....	24, 54
gossip .....	24, 54
records/registration.....	31-32, 51, 81-83
starting an Al-Anon group.....	30-39, 81-83
starting an Alateen group.....	31-34, 87-90
reports.....	55-56, 123-124
resources.....	60-62
service positions (see also Links of Service).....	39, 46-48, 62-69
contacts, phone .....	34-35, 70
CMA (Current Mailing Address).....	34, 36, 39, 47, 51, 70, 156, 158
Group Representative (GR).....	47-48, 55, 56-57, 62-63, 66, 70, 133, 141-142, 146-147, 155-157
officers/alternates.....	46-48
rotation.....	46-48
Group Conscience.....	51-53, 139-141
<i>Group e-News</i> .....	34, 61
Group Records Coordinator, Area.....	147, 148, 159
Group Representative (GR)	
definition/duties of.....	47-48, 55, 62-63, 66, 146-147, 155-157
expenses.....	56-57, 99, 147
reports.....	55, 155-157
term of office.....	48, 133
Groups at Work (see Al-Anon & Alateen Groups at Work)	
GSO (See General Service Office)	
Guidelines for Al-Anon/Alateen Service .....	60-61, 105

## H

Handbook (See World Service Handbook)

History

of Al-Anon .....	28-29
of Alateen .....	29
of Concepts .....	179-180
of World Service Conference.....	28-29, 139-141
of Al-Anon World Service Conference Charter .....	214-216
of World Service Office.....	28-29, 139-141
How to start a group (WSO Registration Process) .....	30-34
Al-Anon .....	30-31
Alateen.....	32, 88

## I

IAGSM (See International Al-Anon General Service Meetings)	
Incorporation/Taxes .....	117-119
Non-profit status.....	58, 117
Information Service, Al-Anon/Intergroup .....	63-65, 71, 100-101, 112-114, 119, 120, 162, 166
Information Service Representative (ISR).....	48, 65, 147
Inmate Correspondence Service.....	73
“Inside Al-Anon” (See World Service Office newsletters)	
Institutions group (See Introductory Meetings)	
Insurance .....	59
Intergroup (See Al-Anon Information Service)	
Interim Assemblies.....	163-164
International Al-Anon	
International Coordination Committee (WSO).....	69, 73-74, 208, 210-211
International Al-Anon General Services Meetings (IAGSM) .....	73-74, 210-211
Internet .....	91-92, 93, 114, 116
Introductory meetings .....	83-84

## J

Jewelry (medallions, trinkets).....	97
-------------------------------------	----

## K

Knowledge-Based Decision-Making to Make an Informed Group Conscience (KBDM) .....	68
---	----

## L

Leadership .....	46-48, 198-202
Legacies (Steps, Traditions, Concepts of Service).....	13-20, 179-225
Liaison members (Al-Anon Information Services/Intergroups).....	65, 71, 133, 166
Limited access, facilities with .....	81, 90
Links of service .....	62-69, 146-149, 155-162
Literature (See also Conference Approved Literature and Service tools) .....	60-62, 102-108
Literature Distribution Center (LDC) .....	64, 72, 100
Logos .....	102, 103, 105, 106-107
Lois W. (Al-Anon Co-founder) .....	28, 85, 137, 139-141, 179, 216
Lone Members.....	73

## M

Meetings (See also Group)	
beginners/newcomers.....	37, 41, 45
electronic (Internet and phone).....	38-39, 84
ideas.....	43-45
locating.....	83, 100
meeting format.....	8-9, 10-27
Suggested Closing .....	22

Suggested Welcome.....	10-11
multiple meetings, groups with .....	37-38
open/closed.....	11, 36-37, 83, 89, 99
sharing at .....	40-41, 123-125
where to hold.....	35, 57-58, 121-122
Membership in Al-Anon/Alateen.....	40, 81

## N

Newsletter Editors.....	65, 72, 82-83, 131-132, 162
Newsletters (See World Service Office Newsletters)	

## O

Obstacles to success (See Three Obstacles to Success)	
On-line meetings (see Electronic Meetings)	
Optional readings.....	23-27
Anonymity.....	23
Four Primary Ideas .....	23-24
Three Obstacles to Success in Al-Anon .....	24
<i>Understanding Ourselves and Alcoholism</i> .....	25-27

## P

Phone contacts.....	34, 47, 70
Policy Committee (WSO) .....	69, 79-80, 136-137, 208-209
Policy Digest (See Digest of Al-Anon and Alateen Policies)	
Preamble to the Twelve Steps, Al-Anon and Alateen.....	12
Primary Ideas (See Four Primary Ideas)	
Public Outreach.....	45, 49-51, 91-92, 109-116, 156-157
anonymity.....	41-43, 50-51, 91-93, 111, 114-116
attraction vs promotion.....	109-110, 113-114
cooperation vs affiliation .....	109-110
cooperation with A.A. ....	120
Coordinators.....	131-132, 156-157
events.....	50-51, 110-111, 114
flyers .....	112
international.....	111-112
Internet .....	91-92, 93, 114, 116
local .....	50-51, 110-113
mailing addresses.....	91-92, 93, 123
media, in the (radio, films, TV, Internet) .....	91, 114-116
national .....	111-116
outreach to professionals .....	49-51, 91-92, 110-111
posters.....	112
public outreach literature.....	112-113
public outreach paid ads.....	112
public outreach publications AIS/Area.....	113
public service announcements (PSAs) .....	113
roles and responsibilities .....	111-112
social networking.....	116
spiritual principles of .....	110-116

carrying the message .....	110-113
attraction, rather than promotion .....	109-110, 113-114
maintaining personal anonymity .....	91, 113, 115
cooperation and goodwill.....	115
continually broadening the ways to carry the message .....	115-116
writing about Al-Anon/Alateen.....	114-115
Public relations (See Public Outreach)	
Publications (See Conference Approved Literature, Literature, and Service Tools)	

## Q

Quarterly appeal.....	47, 55, 58, 95-96
Quorum .....	174, 192

## R

Raffles/Lottery tickets .....	98
Resources for members and groups .....	60-62
Religion/philosophies.....	24, 54, 123-124
Rent, group .....	56-58, 99
Reserve fund.....	96-97, 216-219
Retreats .....	123-124
Right of decision.....	185-188
Right of participation .....	188-190
Rights of appeal and petition .....	190-193

## S

Selected committees (See Concept Eleven)	
Serenity Prayer.....	8, 10
Service in Al-Anon/Alateen.....	39, 46-48, 82-83
Service arms, service entities.....	62-69, 96, 100-104, 139-145, 146-149
Service positions .....	39, 46-48, 147-149
Service tools .....	60-62, 102-106
Social networking.....	116
Speakers .....	45, 98-99, 121
Sponsorship.....	48-49
Alateen Group Sponsor .....	31-34, 49, 71, 87-90
Alateen personal Sponsor .....	49, 71
Al-Anon personal Sponsor .....	48-49, 70-71
Service Sponsor .....	49, 71
Steering committees.....	39, 48, 53
Steps (See Twelve Steps)	
Structure of the Al-Anon/Alateen fellowship .....	62-69, 131-134
Supporting group growth.....	49-51
Symbols/logos.....	102, 103, 105, 106-107

## T

Taping .....	84, 86
Task force.....	68

Tax exempt status.....	58-59, 117-118
TEAM (Together Empowering Al-Anon Members) .....	73
Telephone meetings (See Electronic Meetings)	
Terms used in Al-Anon service.....	70-74, 131-134
<i>The Forum</i> .....	43-44, 47, 55, 61, 94, 104-105, 164, 211
Things to consider when starting an Al-Anon/Alateen group .....	34-38
Thought force.....	68
Three Legacies (Steps, Traditions, Concepts of Service) listed .....	13-20
“Three Obstacles to Success in Al-Anon” .....	24, 54-55
Traditions (See Twelve Traditions)	
Trinkets (jewelry, coins, medallions) .....	97
Trustees (See World Service Office Board of Trustees)	
Twelve Concepts listed .....	19-20
Twelve Steps listed.....	13-14
Twelve Traditions listed.....	15-16
Twelve Traditions of Alateen listed.....	17-18
Types of meetings .....	11, 36-37, 83-84

## U

Unanimity.....	220-221
----------------	---------

## V

Vision .....	201-202
Volunteers.....	133, 137, 188
Voting.....	51-53, 82, 141-145, 149-155, 160, 162-163, 171-175, 220-221

## W

Warranties .....	20, 172, 174-175, 214-225
Warranty One .....	216-219
Warranty Two .....	219-220
Warranty Three .....	220-221
Warranty Four.....	21-225
Warranty Five.....	225
Web sites, Al-Anon.....	60, 83, 91, 93, 108, 114-116, 136
Welcome, suggested .....	10-11
Welcoming newcomers.....	21, 41, 45
World Directories .....	106
World Service Conference (WSC)	
committees (selected) .....	68-69, 133, 136-139, 160-161, 207-213
composition of.....	66, 142-143, 171
definition of.....	134
historical background .....	28-29, 139-141
how it is financed .....	145-146
Delegates’ equalized expense.....	145-146
how it works.....	143-144
voting .....	141-145, 171-172, 173
joining the WSC.....	146
purposes of.....	139
structure.....	66-67, 141-142



Area Assembly .....	132
links between groups and structure .....	66-67, 141-142, 155-157, 162-163
suggested procedure.....	143
task and thought forces.....	68-69
World Service Conference Charter (See Al-Anon World Service Conference Charter)	
<i>World Service Conference Summary</i> (P-46) .....	60, 66-67, 105, 145
World Service Delegate.....	65, 72
definition/duties of .....	72, 134, 160-161
election of .....	141-142, 150-151
expenses.....	145-146, 152-153
term of office.....	150-151, 173
<b>World Service Handbook</b> .....	131-166
purpose of.....	131, 143
revisions to .....	131
World Service Office (WSO)	
administration/staff.....	67, 101, 133, 134, 213-214
Al-Anon Family Group Headquarters, Inc.....	117, 135-141
Board of Trustees.....	67-69, 136-139, 173-174
composition of.....	137, 173-174
election of .....	137-139
reorganization of.....	138-139, 173-174
responsibilities of .....	138-139, 173-174
rotation/term of office.....	137
committees.....	136-137
WSO selected committees.....	68-69, 208-213
WSO task force.....	69
WSO thought force.....	68
WSO work group .....	68
contributions to .....	56-58, 95-97
copyright and reprint permission.....	106-108
Executive Committee.....	67, 137, 188-190
Executive Director .....	133, 136-139, 188-190, 208, 213
incorporation of .....	117
newsletters.....	61, 106
Policy Committee .....	69, 79-80, 136-137, 208-209
reserve fund .....	96-97, 216-219
structure/what it does.....	135-138
World Services	
definition of.....	134
evolving national structures .....	73-74, 117-118, 133
General Service Offices.....	67, 73, 117-118, 133
International Al-Anon General Service Meeting (IAGSM).....	73-74, 134, 210-211
Work group .....	68
WSC (See World Service Conference)	
WSO (See World Service Office)	
WSO publications (See Conference Approved Literature [CAL], Literature, Service Tools)	
WSO Board of Trustees (See World Service Office)	



AL-ANON FAMILY GROUPS  
*hope for families & friends of alcoholics*